

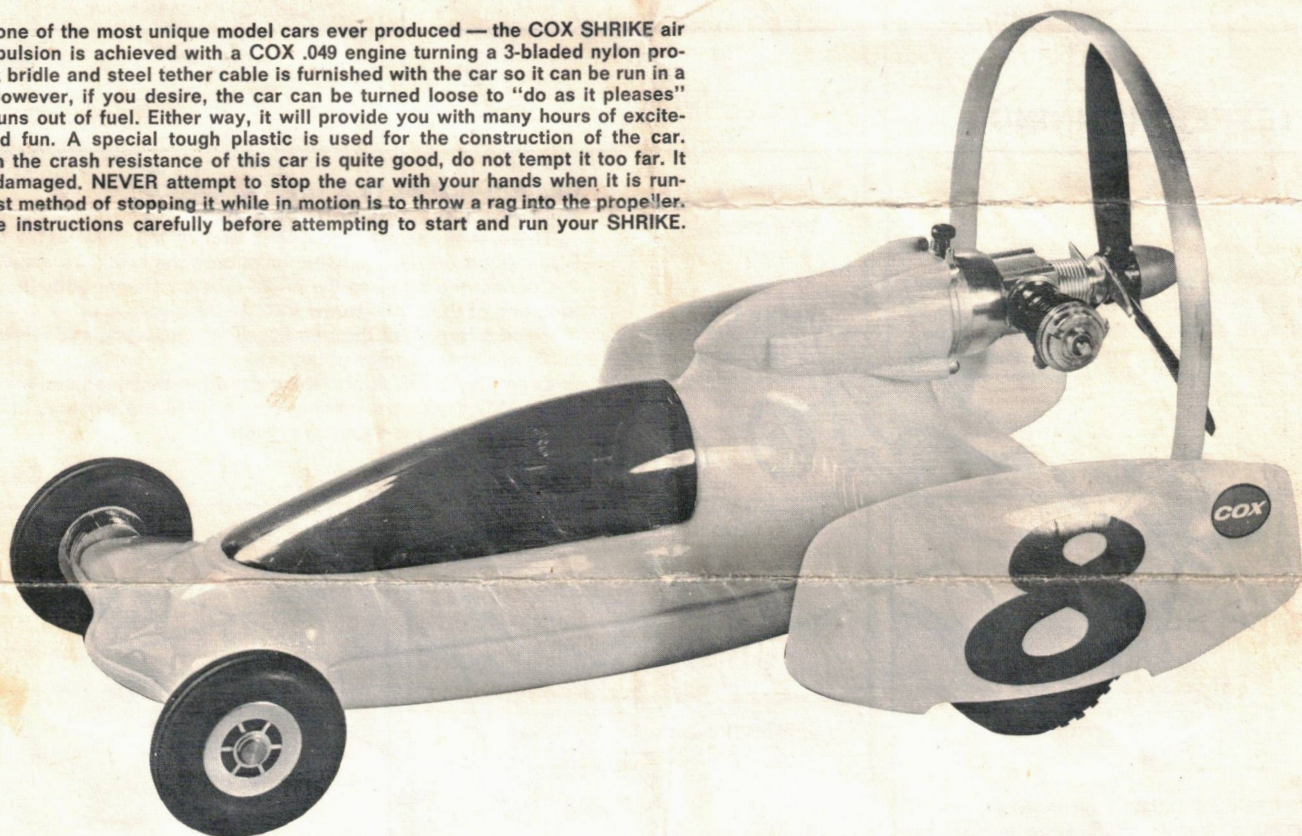

SHRIKE

.049 Engine Powered Air Car

Here is one of the most unique model cars ever produced — the COX SHRIKE air car. Propulsion is achieved with a COX .049 engine turning a 3-bladed nylon propeller. A bridle and steel tether cable is furnished with the car so it can be run in a circle. However, if you desire, the car can be turned loose to “do as it pleases” until it runs out of fuel. Either way, it will provide you with many hours of excitement and fun. A special tough plastic is used for the construction of the car. Although the crash resistance of this car is quite good, do not tempt it too far. It can be damaged. NEVER attempt to stop the car with your hands when it is running. Best method of stopping it while in motion is to throw a rag into the propeller. Read the instructions carefully before attempting to start and run your SHRIKE.



IMPORTANT — PLEASE READ!

USE COX GLOW FUEL, GLOW POWER FUEL
OR CUSTOM BLEND FUEL ONLY IN THIS MODEL

1. The most important part on your car is the PRECISION COX ENGINE. Exact needle valve setting depends upon factors such as humidity, temperature and elevation. Since these factors are not the same at the Cox factory as where you live, factory presetting of the needle valve for best per-

formance is impractical.

2. Car should be cleaned thoroughly after each running session. Use soap and water or plain alcohol to clean plastic parts.

FREE RUNNING

If it is desired to run your car so that it skids and spins, just fire it up and turn it loose. Be sure the engine is running in the right direction. Wind from the propeller MUST be blowing AWAY from the engine. Free running is best accomplished on a smooth surface. NEVER run your car on a dirt surface as dust will get into the engine and greatly reduce

the life of the engine and its starting ability. Different propellers have considerable effect on spins. COX makes several different size propellers for this engine. Try a few of them to get the best results for the surface you are running the car on. These propellers are available at any hobby shop.

READ ENTIRE INSTRUCTION SHEET
BEFORE ATTEMPTING TO START ENGINE OR TURN NEEDLE VALVE

1 INSTALLING ROLL BAR

The roll bar should be installed before car is run, especially if car is to be run free. The roll bar will help prevent propeller damage if car should flip over while running. To install, simply press ends of roll bar into slots in rear wheel skirts as shown in illustration.

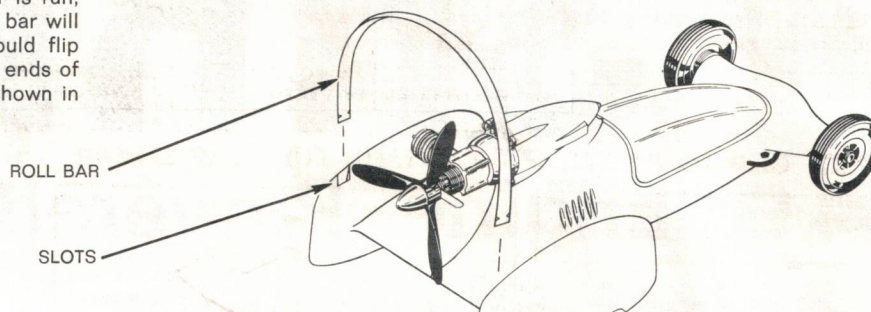

2 TETHER RUNNING

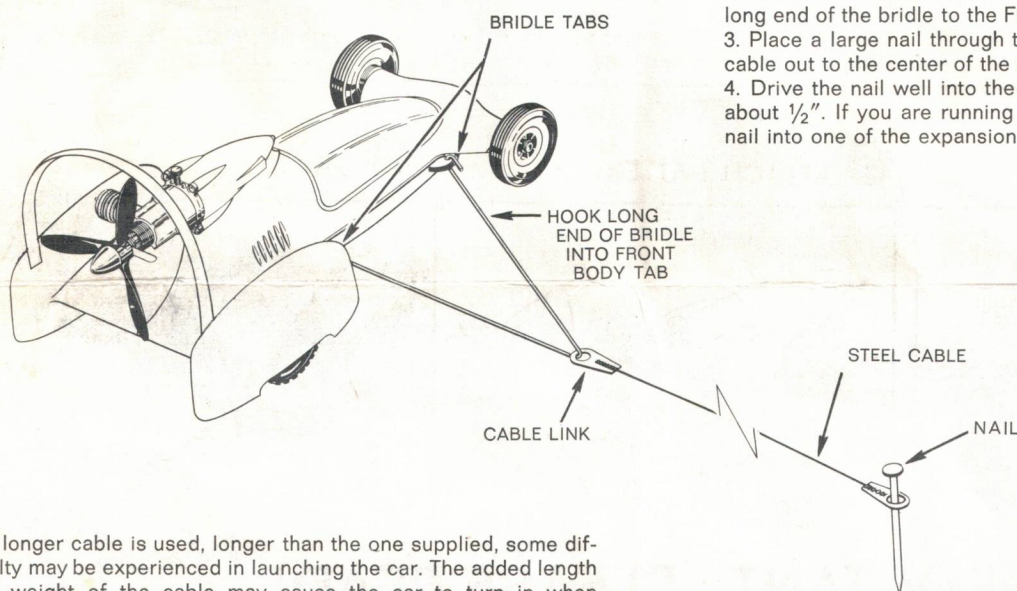

CAR SHOULD BE RUN ON A CLEAN ASPHALT OR CONCRETE SURFACE.

1. There is a cable link on each end of the steel cable tether. Place either one of the cable links onto the bridle as shown.
2. Connect the bridle to the bridle tabs on the car body (hook the long end of the bridle to the FRONT tab).
3. Place a large nail through the other cable link and stretch the cable out to the center of the track.
4. Drive the nail well into the asphalt so that the head sticks up about $\frac{1}{2}$ ". If you are running car on concrete surface, drive the nail into one of the expansion joints.

If a longer cable is used, longer than the one supplied, some difficulty may be experienced in launching the car. The added length and weight of the cable may cause the car to turn in when released. To overcome this, give the car a push so that it gets going at a high enough speed to hold the cable tight right from the start.

IMPORTANT—READ BEFORE STARTING ENGINE

Naturally you're anxious to get your car running — BUT take a few minutes to read the Engine Starting section BEFORE you go ahead with starting your COX engine. You may save yourself trouble and delays by doing things right the first time.

Use only COX fuel in the engine. Engine will not operate on diesel fuel, gasoline, benzene or other petroleum base fuels. If attempt is made to use other than proper fuel BOTH ENGINE AND CAR WILL BE RUINED!

ENGINE OPERATING TIPS

1. Never put car away with fuel in tank (run engine until tank is empty). Fuel left in tank will partially evaporate leaving a thick castor oil residue which will block the passage of fuel when you attempt to start the engine. If this should happen many starts on the prime charge will have to be made before the castor oil will be softened and sucked through. Only then will the engine pick up fuel and continue to run.

2. If necessary, remove needle valve and blow into needle

valve hole with a service station tire hose, a squeeze bulb or any convenient source of air pressure. This should force out congealed castor oil from previous running.

3. Never leave fuel continuously exposed to air or sun as it will thicken and cannot be used.

4. Upon the first sign of failure to start, check Glow Head to see if it is tight. Vibration may loosen Glow Head while engine is running. Engine will not start if Glow Head is loose.

STARTING ENGINE

(When using Cox No. 330 or 440 Kit)

NOTE: If your plane came complete with fuel and battery, refer to instructions on the fuel and battery box.

EQUIPMENT FOR STARTING ENGINE

(All contained in Cox 440 Kit)

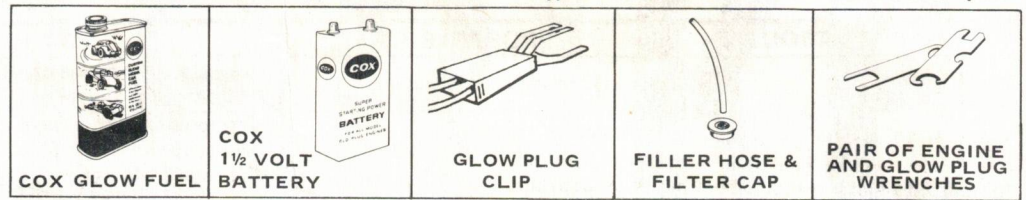

1 CONNECT CLIP TO BATTERY

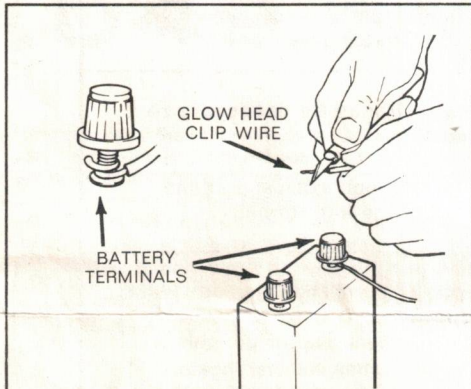

Strip about 1/2" of the insulation from the ends of both Glow Head Clip Wires. Attach battery terminals as shown.

2 ATTACH FUEL CAP & HOSE

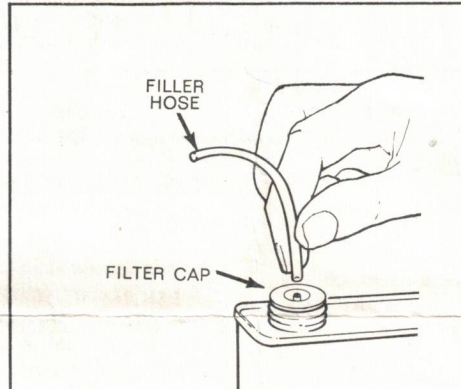

Remove lid from can of fuel and insert Fuel Filter Cap. Attach Filler Hose to cap spout.

3 ADJUST NEEDLE VALVE

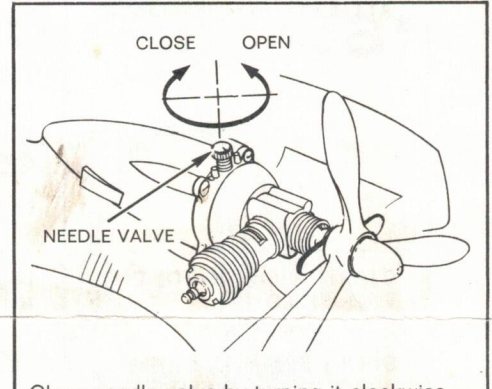

Close needle valve by turning it clockwise — **do not force it!** Open needle valve 2 1/2 turns (turn counterclockwise to open). **This is the approximate setting for starting.**

4 FUEL UP

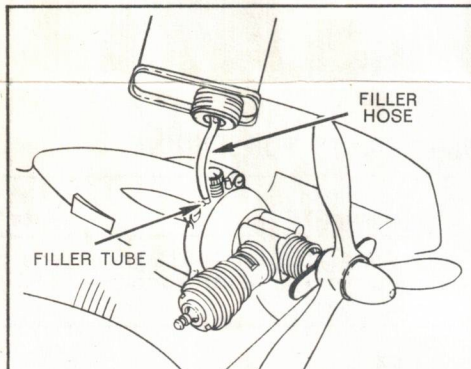

Remove "BEFORE STARTING" sticker from over filler tubes. Attach the Filler Hose to EITHER filler tube. Squeeze can to fill tank until fuel spurts from the other tube.

5 ATTACH BATTERY

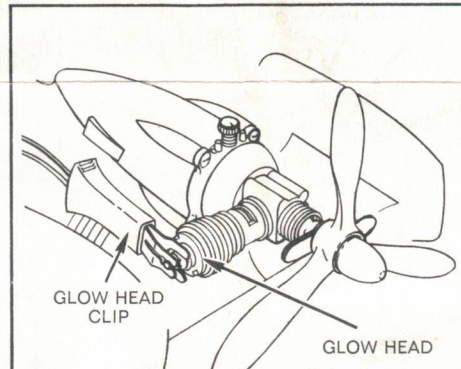

Attach glow head clip to glow head as shown. Wires must be tightly connected to the battery and firmly attached to the glow head.

6 PRIME

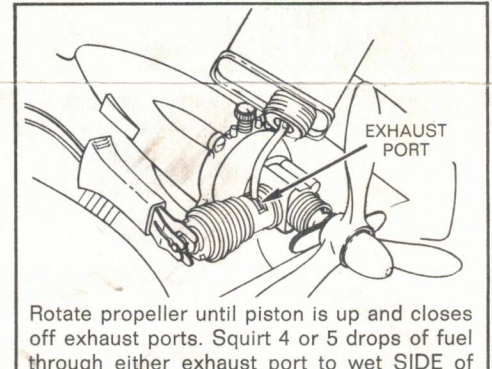

Rotate propeller until piston is up and closes off exhaust ports. Squirt 4 or 5 drops of fuel through either exhaust port to wet SIDE of piston with fuel. The object here is NOT to fill the cylinder with fuel but to put only a small amount in. **TOO MUCH FUEL WILL FLOOD THE CYLINDER AND PREVENT STARTING.**

7 START

Place end of spring starter over starter catch. Hold propeller tip with thumb and first finger. Wind propeller **ONE FULL TURN ONLY** counterclockwise — then release it quickly. **SPRING MAY BE DAMAGED IF WOUND MORE THAN ONE FULL TURN.** The Spring Starter will spin propeller in opposite direction and start engine. If engine does not start, prime again and repeat starting procedure. Repeat 3 or 4 times. If engine starts and then dies, open needle valve 1/2 turn and repeat starting procedure, prime engine each time. Repeat this procedure, opening needle valve 1/2 turn each time until engine does start (as much as 4 turns open on needle valve may be required for starting so don't give up too soon!). See Trouble Shooting Chart on next page.

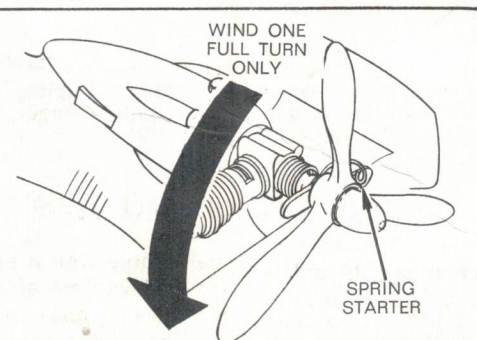

After engine starts, **SLOWLY** close needle valve (clockwise) until engine runs at "peak" speed. **Disconnect battery clip from Glow Head.**

STARTING ENGINE AFTER CAR HAS BEEN RUN AND SETS FOR AWHILE

If car has not been run for awhile, prepare it for running before attempting to start the engine. The following is good procedure even if the car has been idle only a few hours but is not necessary for the first start of a new car.

1. Screw out the needle valve, put a drop or two of fuel in the needle valve hole and then either blow it out with air pressure or run a pin or fine wire about 28 gauge or .015 diameter to the bottom of the needle chamber.
2. Clean burned castor oil deposit from top of Glow Head if any has accumulated.
3. Normal starting procedure will now be quickly effective.

TROUBLE SHOOTING CHART

TROUBLE	PROBABLE CAUSE	REMEDY
WILL NOT START — ACTS LIKE BATTERY WASN'T ATTACHED TO GLOW HEAD.	Poor battery connection	Check connections of wires to battery and be sure clip is firmly and correctly attached to glow head.
	Weak or dead battery	A good battery should test 1½ volts or connect battery to a glow head that is known to be good. If glow head filament does not glow bright orange — replace battery.
	Burned out glow head	Glow head filament should glow bright orange when a battery that tests 1½ volts is connected to it. Reflection from this glow can be seen on top of the piston through the exhaust port. It may be necessary to remove glow head from the engine to see the filament glow.
	Burnt fuel residue build up on glow head preventing good contact between glow head clip	Wipe glow head clean — it may be necessary to scrape the top of the head.
	Engine wasn't primed	Squirt a few drops of fuel through exhaust port and onto side of piston then continue with starting procedure.
STARTS WEAK, SPITS OUT FUEL & DIES	Engine flooded, getting too much fuel in cylinder	Close needle valve. Leave battery attached to glow head and turn propeller (without priming) until short starting "bursts" occur. Open needle valve 2½ turns, prime and start again.
SHORT RUNNING "BURST" (BRIEF START, THEN STOP).	Engine not getting enough fuel (mixture too lean or tank empty)	Check fuel tank level — refill if necessary; or, open needle-valve another ½ turn, prime and start again. It may be necessary to repeat this procedure 3 or 4 times, opening the needle-valve ½ turn each time.
ROUGH SOUNDING ENGINE; SLUGGISH; WEAK POWER.	Loose glow head	Tighten Glow Head with wrench supplied.

REPLACEMENT PARTS

ENGINE—EXPLODED VIEW

IMPORTANT: Refer to this illustration for disassembly and reassembly of engine.

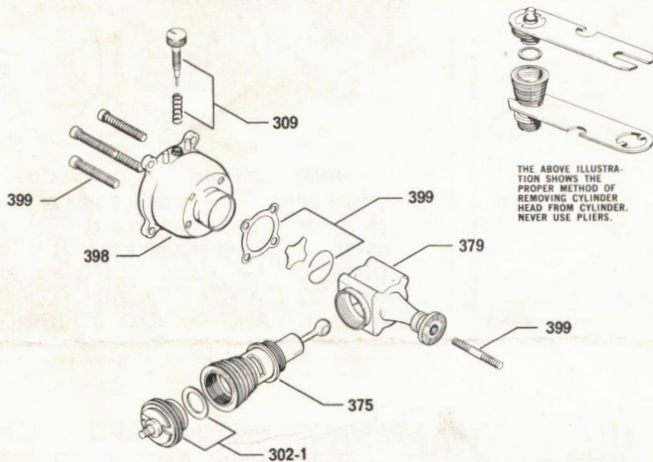

IMPORTANT: See your local hobby dealer for parts. If he does not have them, you may order direct from factory. Use part numbers as shown when ordering. Send your remittance with your order. No C.O.D.'s, please. If you live in California, add 5% Sales Tax.

WARRANTY

This engine is guaranteed against defects in materials and workmanship for 30 days from date of purchase. Glow Plugs are never guaranteed because of their delicate nature. No other guarantee is made or implied. Do Not Take Engine Back to Your Dealer, mail directly to factory for service.

REPLACEMENT PARTS FOR ENGINE

Part No.	Description	List Price
Minor repairs, examinations, or adjustments — \$2.00 plus parts. Complete overhaul (guaranteed new engine performance) — \$4.50 including parts.		
302-1	Glow head & gasket	\$1.10
309	Needle valve & spring	1.00
375	Cylinder, piston & rod	3.50
379	Crankcase, crankshaft & drive plate	3.50
398	Tank front & back, tube, spring & venturi gasket	3.00
399	Overhaul kit (reed, retainer, gasket, screw set, prop screw & venturi gasket)	1.25

REPLACEMENT PARTS FOR SHRIKE

Part No.	Description	List Price
*338	Spring starter	\$.75
350-2	Engine, .049	7.50
994	Prop, 5" dia. x 3" pitch — 3 blades50
995	Set of screws60
9100-3	Pair of wheels & tires, axle & retainers	3.00
9100-4	Front wheels, tires, axle & retainer	2.75
9100-5	Body top & bottom, body screws, roll bar, engine nacelle & lock, engine mounting screws, prop spinner, stud & nut, bridle, set of stickers & canopy	5.00

*Patent No. 2,927,660

Prices subject to change without notice

L. M. COX MANUFACTURING CO., INC.

a subsidiary of LEISURE DYNAMICS, INC.

1505 East Warner Avenue, Santa Ana, California 92705

© L. M. COX MANUFACTURING CO., INC., 1974