

May, 1990

\$2.95

\$3.50 Canada



COMPETITION



PLUS THE R/C CAR MAGAZINE

- FUTABA'S
MAGNUM FORCE

- REEDY'S OVAL
RACE OF CHAMPIONS



- PARMA'S
PRO PANTHER 12

.049 GTP NISSAN

Radio Controlled 1/12 Scale On-Road Race Car

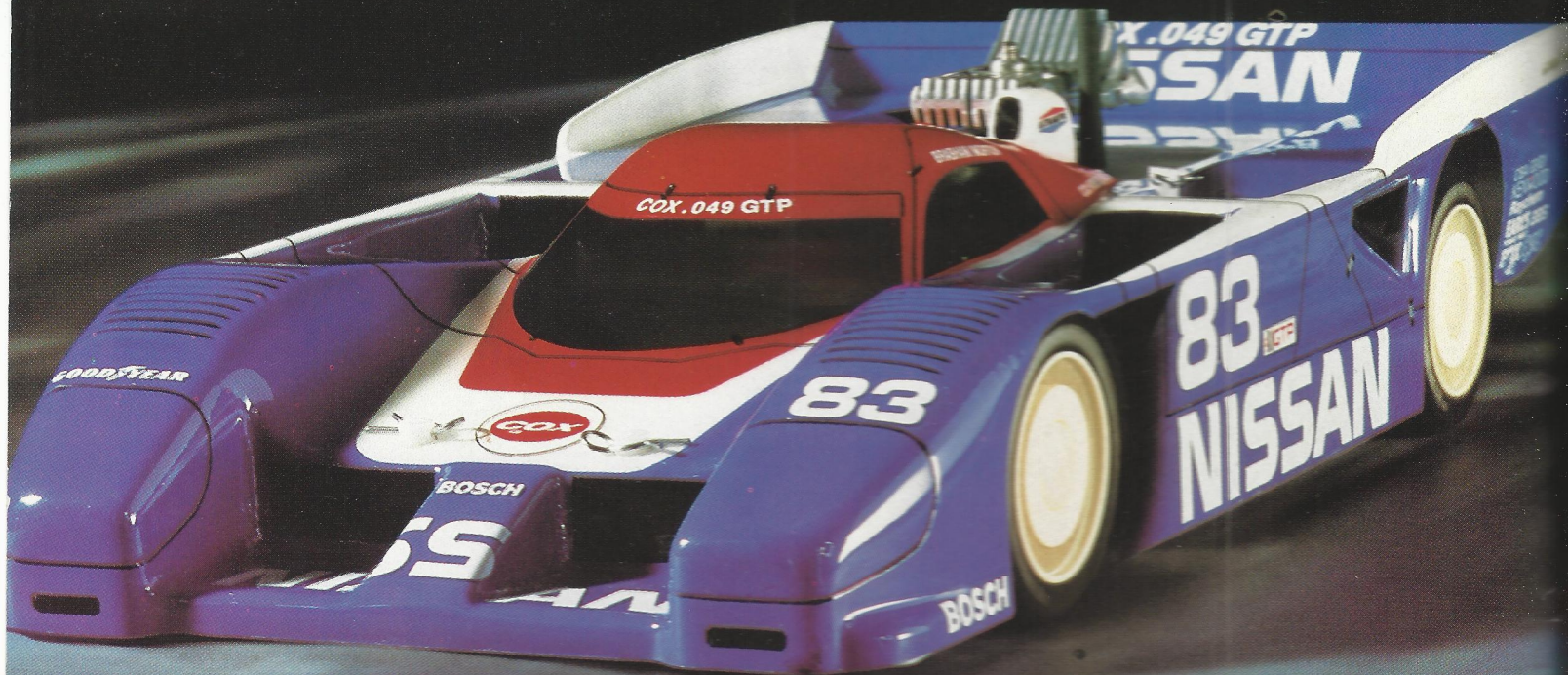

GAS* POWERED

*Use Cox Super Power Fuel Only

You're looking at the newest car to hit R/C racing.

The Cox .049 GTP Nissan.

It's powered by the world's finest small engine, the Cox .049.

There's nothing like it.

Running at peak performance, the incredible Cox .049 engine turns an awesome 23,000 RPM. . . That gives you the thrilling sound of full size racing.

Full out, the .049 GTP Nissan travels in excess of 30 MPH. . . That delivers the speed you need for exciting, competitive racing.

The .049 GTP Nissan combines the latest R/C racing technologies: minimal weight, fiberglass chassis, rear axle differential and independent coil front suspension. . . That enables you to corner the .049 GTP like it's riding on rails.

The engine burns Cox fuel. . . That produces the same smell of nitro you experience at full size race tracks.

Give your racing some gas.

Drive the new Cox .049 GTP Nissan.

You'll find it at your favorite race track or hobby shop.



350 West Rincon Street
Corona, CA 91720

STRIKE FIRST

with TRINITY BRUSHES

No matter what type of racing you do, there is a high horsepower, low friction, long wear Trinity Motor brush to suit your needs!

Trinity brushes are molded, not cut like cheap copies, which are prone to stress related breakage. These brushes are designed as replacements for all Trinity, Orion, Yokomo, Kyosho and Air Supply motors.



Slotted Dual Brush System

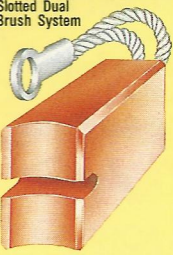

The first new brush designed for today's motors! Dual shunts for lowest resistance, new non-glazing formula. Slotted face for less arcing, less heat build-up and a more positive brush to commutator contact area. These are the only brushes that allow the hottest 8 thru 14 turn modified motors to produce maximum horsepower. #4103-\$3.50

Contoured, Triple Cuts

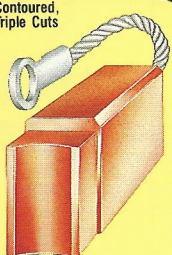

For 1/12 scale, on-road cars. Gives more torque and less arcing by maximizing the ratio of current draw vs friction on the commutator. For 14 to 20 turn motors. Speedworks 0007, 0012. #4034, soft compound for 4-cell #4037, for 6-cell \$4.99

Full Size Replacements

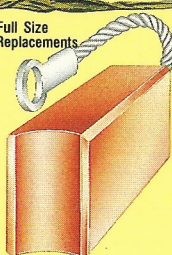

#4005, \$5.25 Soft compound comes in stock Trinity and Speedworks motors. w/springs. #4038 \$3.00 Hard compound for longer life in off-road motors. In Trinity modifieds 1700 to 1704. #4046 \$3.00 Soft compound produces higher rpms in stock and on-road motors. #4065 \$1.99 Same as 4038 but without terminal.

Timed Brush

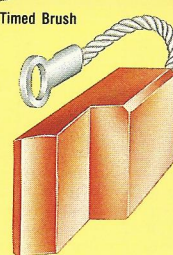

Shape increases timing and RPM's in stock motors. These work so well they should be illegal! For Trinity 2000, 2020, Speedworks 0004, 0005, 0444 and all Yokomo and Kyosho stock motors. #4007 - \$4.79

Cut Brush

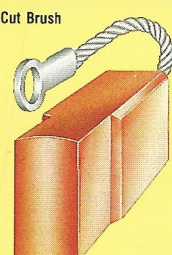

The narrow face increases RPMs, reduces arcing. Designed for oval racing or motors with lots of timing advance. #4006 - \$4.79

Off-Road, Cut Brush

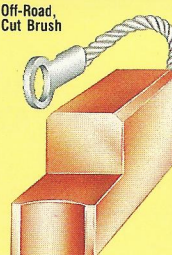

For on and off-road motors with 14 turns and more. Less friction on commutator gives higher rpm's and more torque. Hard compound for longer life. Used in Trinity 1705 thru 1711 and Speedworks 0001, 0002, 0003, 0008, 0009 & 0555. #4035 - \$4.79



Trinity Products, Inc.

1901 E. Linden Ave., #8, Linden, NJ 07036 • (201) 862-1705 • FAX: 201-862-6875

KYOSHO

MEGA
Motor™

Great racing motors.

Regardless of price.



There are certain racing motors that you could pay a lot more for than a **Kyosho Mega Motor**. But very few would give you so much in return.

Mega Motors are matched to your kind of racing with many hot winds to choose from. Monster truck, on-road, off-road, oval ... we've got your motor. Selection is easy with a Mega Motor application chart on every box.

If money is a factor you'll find Mega Motors awesomely affordable. Still you get maximum muscle from wet magnets, diamond-trued commutators, and solid construction. And each Mega Motor meets Kyosho's high quality standards. They're manufactured to exacting tolerances and carefully hand-inspected at the factory.

Check out Mega Motors at your hobby dealer. All powerful. All affordable.



WINDS X TURNS	MEGA MOTOR APPLICATION CHART											
		1/10 PAVED OVAL	1/12 PAVED OVAL	1/10 DIRT OVAL	1/10 2WD OFF-ROAD	1/10 4WD OFF-ROAD	1/10 ON-ROAD	1/12 ON-ROAD	TRUCK RACING	TRUCK PULLING	ELECTRIC BOATS	ELECTRIC PLANES
12X2	PAVED OVAL	★	★	▲	•	•					•	•
14X2	DIRT OVAL	▲	▲	★	•	▲	•				•	•
16X2	4WD OFF-ROAD	•	•	▲	▲	★	▲	•	•		•	•
18X2	2WD OFF-ROAD			•	★	▲	★	▲	•		•	•
20X2	ON-ROAD				▲	•	★	★	•		•	•
22X1	OUTLAW STOCK	•	•	•	▲	▲	•	▲	•	•	•	•
360	MONSTER TRUCK				•	•				★	★	★

★ = EXCELLENT FOR THIS APPLICATION. ▲ = VERY GOOD FOR THIS APPLICATION.
• = ACCEPTABLE FOR THIS APPLICATION UNDER CERTAIN CONDITIONS.

Look for new
360 Monster Truck
and **Outlaw Stock**
Reverse Rotation Motors!

DISTRIBUTED TO LEADING RETAILERS
NATIONWIDE EXCLUSIVELY THROUGH



Send to the address above for your **FREE** copy of Kyosho's Mini Catalog.

MEGA MOTORS™ is a registered trademark of Darda, Inc. USA, manufacturer of Darda racing cars and track sets.



COMPETITION



PLUS

DEPARTMENTS

6 MAILBOX

Letters and Comments From Our Readers

8 FINISH THE LAP YOU'RE ON

Five Minute 1/12th Scale

15 PIT BOARD

Late Breaking News

87 RACING SCHEDULE

Listings of Race Locations and Dates From

Around the Country

99 NEW PRODUCTS

What's New and Hot in the R/C

Car Market

100 ADVERTISER'S DIRECTORY

COLUMNS

10 HARD CHARGING

ROAR News

23 PIT TALK

NORRCA News

27 NRCTPA NEWS

Truck Pulling News

FEATURES

Page 28

NEWSLINE

*12th Scale Indoor Racing on Puget Sound
3rd Annual Winter Midwest Off-Road Championships*

Page 42

PARMA'S PRO PANTHER 12

Parma's entry into the 12th Scale Arena.

Page 50

JRx2 PRO - PART II

The Newly Released Performance Kit

Page 62

REEDY OVAL RACE OF CHAMPIONS

*Top World Drivers Vie For This Title at
Lake Whippoorwill Speedway.*

Page 63

FUTABA'S MAGNUM FORCE

A review of the PCM and AM Radios.

About The Cover

This month's cover features Parma's Pro Panther 12 ready for take-off.

Photo by The Control Room

MAILBOX

RESIGNATION

Dear ROAR Members:

Please accept this as my notification of resignation from the ROAR Executive Board effective upon finding of a replacement. I have enjoyed the privilege and opportunity to work with you and the other board members through the years. It has been a good feeling seeing ROAR grow and being a part of that growth. My resignation is due to personal reasons as business commitments and a realization that I am involved in

too many things, has caused me to pull back a little and make some changes. That, with the fact that it has been many years now and maybe it is time to step aside a little and see some new people come forth, has been the prime reasons for this decision.

I have always supported ROAR and will continue to do so. I will always be available if my ideas or opinions are asked for and I hope that you will see fit to let me continue on as ROAR's International Representative in my present capacity as ROAR IFMAR Director. I enjoy this

international work and involvement tremendously and look forward to being able to devote more effort to it.

Again, I have enjoyed my time working with you and will support you and ROAR every way I can.

Sincerely,
Mike Reedy



Editor's Note:

Everyone on staff at Competition Plus is saddened by the news that Mike Reedy has decided to withdraw from the Executive Board. As a former ROAR President and ROAR Regional Director, Mike is well qualified for this position and we are sorry to see him go. However, we all understand that at times there are too many commitments.

COVER CREDIT

Photo credit for the April issue was given to Dan Bullock, although Dan wrote the article and shot some of the photos in the article, Dennis Weathers actually shot the cover photo. This was our mistake and we would like to give Dennis credit for this cover shot. Dennis shot the cover with a Mamiya RB 67 2 1/4" format camera using Kodachrome 64 film, with Mt. Shasta in the background. Dennis is a professor of Art and Photography at the College of the Siskiyous in Siskiyou County, California. Again we apologize for our error.



THE WINNERS CHOICE
"CHOICE"
BOLINK "STOCK CAR BODIES"

LAKE WHIPPOORWILL SPEEDWAY

<p>4TH CHRIS DOSECK 7TH BOB LIGHT 8TH TIM LANIER 11TH PAUL DAVIS 12TH JIM FULLER 13TH BOB BARTOS 17TH DAVID TIMMERMAN</p>	<p>14TH BOLINK</p> <p>1990 REEDY RACE OF CHAMPIONS</p>	<p>11TH OTHERS</p>	<p>18TH CRAIG KELLY 19TH ART CARONELL 21ST RICK JORDAN 22ND ORLANDO MILLIAN 24TH KEN BUZZARD 25TH BILL HORNE</p>
---	---	---------------------------	--

14 OUT OF 25 INVITATIONAL DRIVERS CHOSE BOLINK BODIES

BOLINK CONGRATULATES
THE 1990 REEDY INV. WINNER
ANDY DOBSON
ANDY THANKS FOR USING BOLINK'S 89 T-BIRD

HOW COME SO MANY TOP NAME DRIVERS RUN BOLINK BODIES?

I HEARD THAT THEY WIND TUNNEL TEST THEIR BODIES FOR BETTER AERODYNAMICS!! Boy, it REALLY WORKS

BOLINK R/C CARS, INC.

SEND \$3.00 FOR YOUR COMPLETE CATALOG.

SEND A SELF ADDRESSED STAMPED ENVELOPE AND RECEIVE A FREE WINDTUNNEL TESTED DEAL SHEET.

420 HOSEA RD (CP) LAWRENCEVILLE, GA 30245
404-963-0252 FAX 404-963-7334

THESE MONSTERS ARE KILLERS!

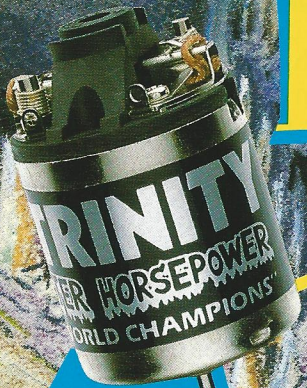
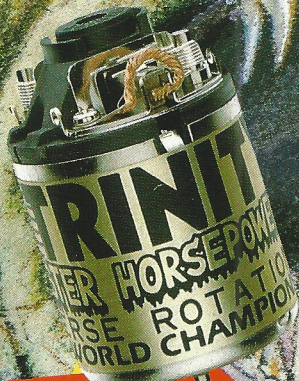

NEW! #2020 "Reverse Rotation Monster Stock" 4, 6 or 7 Cell, Brutal 24,200 RPMs. For Dual/Motor Monster Trucks like the Clod-Buster, Double Dare etc. Totally Outrageous in cars using Hyper Drive.

#2000 "Monster Stock" 4, 6 or 7 Cell, 24,200 Awesome RPMs

You'll be the "Killer" at the track after bolting one of these Monsters in your car.



If ROAR stock class is your bag and you strive to be totally awesome, then you need the most radical, mind-blowing motors around, and here they are: The Trinity Monster Horsepower Stock Motors. Score some in normal or reverse rotation, and you'll be totally prepped to shut down the competition and send 'em home. So, if you really want to be bad, then loose the nerd valley motors and get it on with Trinity Monster Horsepower!

Awsome to the max 2 Time IFMAR World Champion driver Tony Neisinger chooses Trinity Monster Horsepower!

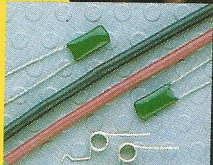
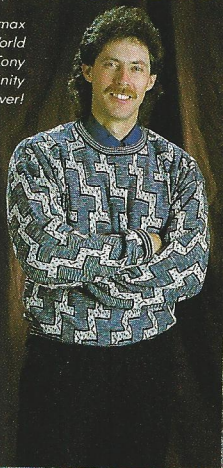

Trinity rad motors don't need bogus hop-up kits to boost 'em to the max. All the trick tech items like 180° Springs, Capacitors and Lead Wires are in the box! Trinity sets you up right the first time.

Speedworks

The Speedworks Era is here!

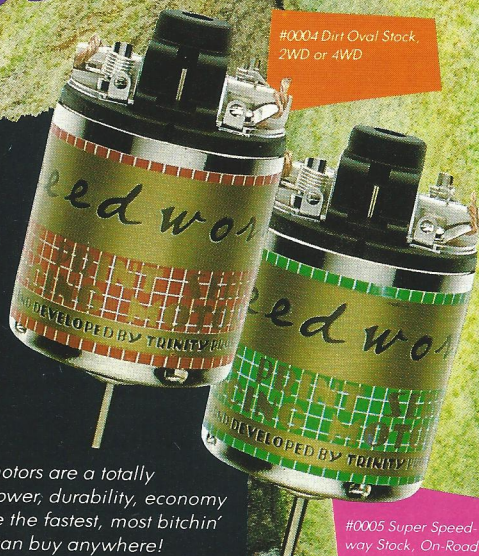
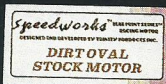

#0004 Dirt Oval Stock, 2WD or 4WD

#0005 Super Speedway Stock, On-Road

Trinity Speedworks motors are a totally awesome blend of power, durability, economy and style. Plus they're the fastest, most bitchin' stock motors money can buy anywhere!

TRINITY™

WORLD CHAMPIONS

TRINITY PRODUCTS INC.
1901 E. Linden Ave., #8, Linden, NJ 07036 • (201) 862-1705 • FAX (201) 862-5875

MONSTER AND MONSTER HORSEPOWER ARE REGISTERED TRADEMARKS OF TRINITY PRODUCTS INC.

© 1987 TRINITY PRODUCTS INCORPORATED

HARD CHARGING

By John Thawley

As popular as R/C racing has become, the pinnacle of that phenomena has to be that of the influx of "big" races. Those of you that travel to these "big" races know what I'm talking

about. There is just nothing to compare with 200-300 racers taking over for a weekend and doing nothing but losing sleep, eating bad, thrashing on cars and just plain old getting outrageous. I love it! The ROAR Regional and National Championships are fine examples of such decadance and bawdiness. While these events are a lot of fun to attend they can also be very rewarding for the promoter or host club.

A question asked often is what is involved in hosting a National or Regional ROAR event and more importantly, how is a host selected?

The first thing you must consider when reviewing this situation is the responsibility that the person doing the selecting is burdened with. When a club or promoter asks for one of these events he is basically asking, in the case of a Regionals, the Region Director to put his (ROAR's) seal of approval on that particular facility and race program. Now I don't know about you, but, I am not about to tell 1500-2000 ROAR members "Hey, this place is great!" unless I really believe it is and that the promoters will genuinely put forth an effort to make it great. I have to have the confidence that the event will live up to the quality deserved of a Championship.

Regardless of the outcome of their decision they usually can't please everyone. Whether its the Region Director selecting the host for a Regional Championships or the Nationals Committee and Executive Committee selecting a host for the Nationals.

I would like to offer some suggestions to the potential hosts and promoters out there on how to go about preparing a bid for a

Championship event. I will also include an outline of information that should be included in your bid.

First and foremost it is important to understand you cannot provide the person having to make the selection with too much information. You cannot just send a letter saying you would like to host the event and expect to get it. Personally, I like to have as much information as I can get.

Think of your bid as a selling job. Remember it is normal for human beings to judge books by covers. Your bid should look good and leave a good impression on the reader. Now that is not to say, you can get away with an empty wrapper.

Also try to keep the time frame in mind when you send your bid or request. I like receiving bids nearly but on the same token that doesn't mean I'm going to award the race to the first bid that comes in. If there are other bids anticipated I will wait to review them all equally. The Region Director also has to allow for scheduling problems with other events in the Region and major or national events. However, it is nice when someone is considerate enough to get their bid in early. If you are in doubt of anything call your Region Director and ask if there is anything in particular he is looking for in a bid. For instance, most Region Directors like to move the event around the Region geographically from year to year. Don't try to be a mind reader. Ask! Communication is the key!

Although a lot of this information has been directed to potential hosts and promoters it is important we racers understand

(Continued on Page 16)



GET IT STRAIGHT THE FIRST TIME!

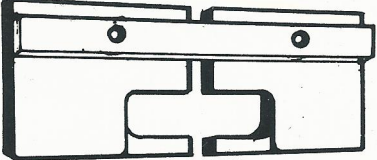

NOW!!! GET THE SAME BRUSH ALIGNMENT ON YOUR STOCK MOTORS THAT MODIFIED RACERS HAVE ENJOYED FOR YEARS. THE FAST Racing Products "BRUSH HOOD ALIGNMENT TOOL" LETS YOU "BLUE PRINT" THE ALIGNMENT OF YOUR STOCK MOTORS BRUSH HOODS TO EXACTLY 180° APART. FOR THE FIRST TIME YOU CAN ADJUST YOUR STOCK MOTORS AND BRING THEM INTO THE SAME SPECS THAT THE ENGINEERS DESIGNED THEM TO RUN.

DON'T BE LEFT AT THE LINE. ORDER YOUR'S TODAY. \$39⁹⁵

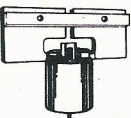

SERIOUS PRODUCTS FOR SERIOUS RACERS

Winner's Circle is
FAST Racing Products
R&D Track.

4320 Puddelock Rd. (804)
Prince George, VA 23875 732-1210

HOBBIES PLUS OF NH, INC.

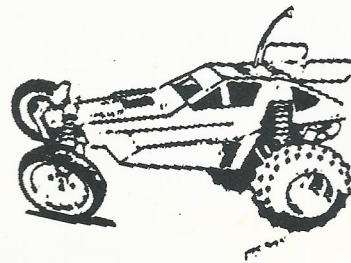

PRESENTS THE

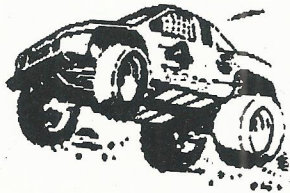

NORRCA

NATIONAL ORGANIZATION FOR RACING RADIO CONTROL AUTOS

1990 NEW ENGLAND REGIONAL OFF-ROAD CHAMPIONSHIPS

JUNE 9-10, 1990 GOFFSTOWN, NEW HAMPSHIRE

NORRCA membership required (Full and Temp. Membership Available at Track). Track is 150 x 75 Packed Clay, Banked Ends. Water Available, Bring Your Table and Power. Plenty of Parking Trackside. Computer Lap Counting. Entry Fee: \$35.00 Stock with Cam Hand Out Motor. \$25.00 All Other Classes.

SCHEDULE: June 8th Controlled Practice All Classes 9 a.m. to 7 p.m. June 9th - Stock Class. Track opens at 8 a.m., Concours at 9 a.m., Racing at 10 a.m. June 10th Modified Class. Track Opens at 8 a.m., Concours at 9 a.m., Racing at 10 a.m. Mains are same day.

• • • SPONSORED BY • • •

NOVAK - FUTABA - GRANITE STATE
RPM - VRP - RRP - ANDY'S - CRP - ZETA - DAN'S - TRC
DAHM'S - BUD'S - STAGE III - TECNACRAFT
RACER'S CHOICE - TWINN-K - LOSI - CAM

OFFICIAL NORRCA ENTRY FORM

Name: _____ Phone _____

Class(es): 2WD STOCK _____ 2WD OPEN _____ 4WD STOCK _____ 4WD OPEN _____

SUPER STOCK TRUCK _____ 4WD OPEN TRUCK _____ OPEN TRUCK _____

Frequencies: 1st _____ 2nd _____ 3rd _____

Beginner _____ Intermediate _____ Advanced _____

NORRCA NUMBER _____

No Entry Refunds. For Additional Info and Directions Call Hobbies Plus at (603) 882-9200.
Send Entry & Check Payable to: Hobbies Plus, 650 Amherst St., Nashua, NH 03063.

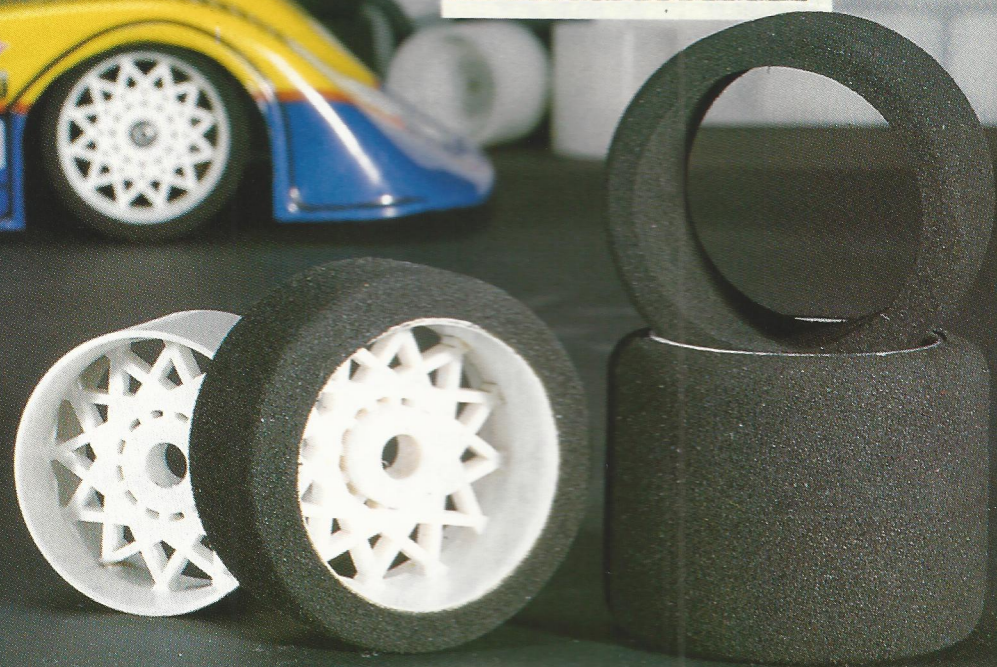
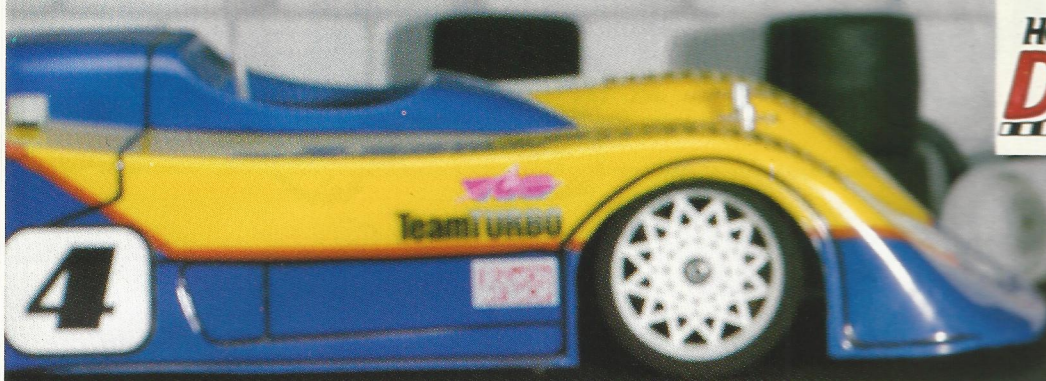

Kick Asphalt!

Many top drivers in on-road competitions choose **DuraTrax foam tires** and **BBS wheels** for their cars.

For them, price isn't always a major concern. It's hard to put a dollar sign on a first-place finish.

But it certainly doesn't hurt that these tires and wheels are priced lower than you've ever seen for on-road traction of such superior quality.

You can choose from compounds that are perfectly matched for what-

ever surface you race on. Maximum traction soft compounds, all purpose compounds, and long-lasting hard compounds give your car a road grabbing edge. They're available mounted on super-strong BBS wheels and pre-trued, or as pre-trued foam donuts, in front and rear styles—twelve different combinations in all. The quality you serious competitors want, at a price that makes getting the gold quite a bargain.

DuraTrax also offers inexpensive medium rubber tires for buggy drivers ready for takin' it to the streets.

Special on-road wheels make the conversion so simple, you don't even need adapters. They are an exact fit for your Kyosho, Tamiya, JR-X2, or RC10 buggy.

Being king of the road is easier than ever, thanks to the economical selection of DuraTrax on-road tires and BBS wheels.

<p>BBS Style Wheels— Fit all on-road cars. Fronts and rears available.</p>	<p>Foam Slicks— Available mounted and trued on BBS wheels or donuts in three traction compounds. Available in fronts and rears in blue, green or yellow.</p>		<p>100% Rubber Block Tread Tire— Designed to fit all rear on-road wheels.</p>	<p>100% Rubber Slicks— Long lasting, high traction. Designed to fit all on-road and BBS wheels, front and rear.</p>		<p>On-Road Conversion Wheels— Designed to turn your off-road buggy into an on-road screamer. They fit RC10, JRX2, Kyosho and Tamiya cars without using adapters.</p>



Send to Great Planes for your **FREE Hobbico DuraTrax brochure.**
 DISTRIBUTED TO LEADING RETAILERS
 NATIONWIDE EXCLUSIVELY THROUGH
GREAT PLANES™
 MODEL DISTRIBUTORS COMPANY
 P.O. BOX 4021, CHAMPAIGN, IL 61824-4021

In Professional Racing the Man in the Driver's Seat Chooses the Right Products He Needs to Take Home the Trophy

ALL-NATURAL

LARGE 8 OZ PRO FORMULA

NEW ODORLESS WINTERGREEN REPLACEMENT



TQ Tire Traction Compound #7011

- All-natural formula
- No harmful fumes
- No petroleum distillates
- Great on carpet, asphalt and concrete
- Maximum bite for heavier transmission cars

TQ8+ Professional Tire Formula #7018

- Pro-formula in 8 oz. size
- No harmful fumes
- Same "feel" start-to-finish
- Long lasting results
- Super on carpet
- Ideal for 1/10 and 1/12th on-road courses

TQ Modified #7019

- New product breakthrough
- All-natural formula
- No harmful fumes
- Superior performance
- Fantastic on carpet and asphalt
- Perfect for flat-chassis ovals and on-road courses

They Call it the Racer's Choice!

OTHER PRODUCTS

- RaceSolv Motor Spray #7013
- HyTech Bearing Cleaner #7012
- BST Battery Strapping Tape #7017
- HySpin Bearing & Bushing Oil #7015
- HySpin + Gear & Diff. Lube #7016
- HyRev Speed Drops #7014

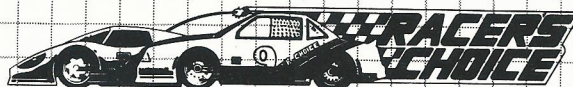

Racer's Choice R/C Products, Inc. • P.O. Box 405 • Modinah, IL 60157
For more information call: (708) 980-4863 or FAX# (708) 980-5420



3025
ELAN "OFF ROAD" - MID OPTIMA

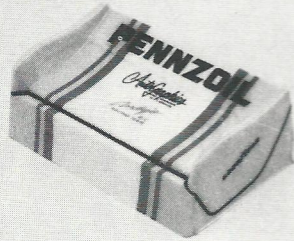

3240
1/10th SCALE "OFF ROAD" WING



3022
HEATHEN "OFF ROAD"

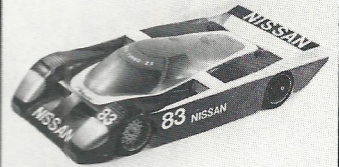

3145
NISSAN GTP



3418
RC-10 REAR BODY MOUNT

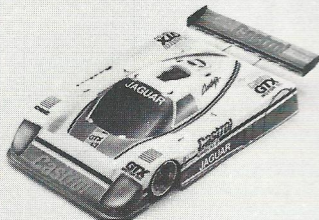

3141 - 4141*
89' JAGUAR GTP

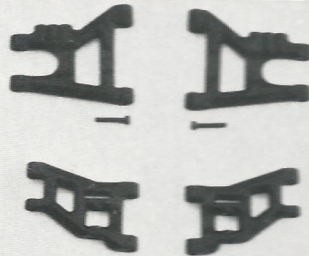

ANDY'S FRONT & REAR ARMS



3162 - 4162*
89' CHEVY LUMINA - NASCAR



3134
1988 VETTE OUTLAW WEDGE

Andy's

R/C PRODUCTS
COMPLETE CATALOGUE \$2.00

Gotcha Covered

RACE PROVEN PRODUCTS

Body Chassis Parts

1/10 Scale Bodies

* 1/12 Scale Bodies

466 W. Arrow Hwy. • San Dimas, CA 91773 • (714) 592-4737 FAX (714) 592-0505
Made in U.S.A.



3420
MONSTER TRUCK FRONT BODY MT.



3412 RC-10 - 3512 ULTIMA
FRONT BUMPER MOUNT "OVAL"

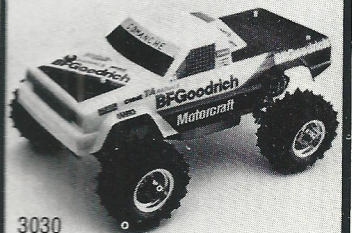

3030
JEEP COMANCHE TRUCK BODY



3026
APACHE WARRIOR - YOKOMO

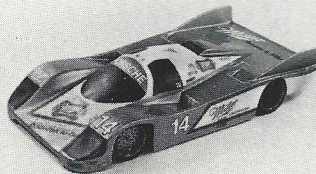

3140
PORSCHE 962 GTP



3023
HALF-BREED "OFF ROAD"



3414 - 3416
RC-10 "OFF ROAD" FRONT BUMPERS



3020 - 3021 - 3024
RENEGADE "OFF ROAD" SERIES



3160 - 4160*
89' PONTIAC GRAND PRIX - NASCAR

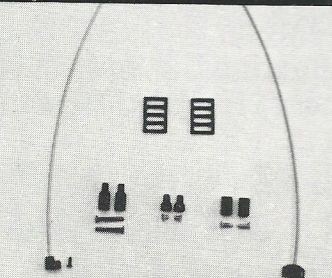

BODY PARTS & ACCESSORIES



3142 - 4142*
TOJ "ON ROAD" BODY

PIT BOARD

THE COUGAR

Developed by the World Championship winning team using advanced technology and innovative design to provide World Class performance out of the box. Straight forward construction and clear concise instructions give experts and beginners alike superb handling and performance every time.

The high quality alloy chassis gives great strength and rigidity with a super low center of gravity. The rear mounted motor puts the weight right where its needed for massive acceleration. The COUGAR high efficiency transmission features a 14 ball differential and high torque kevlar drive belt, strong enough to handle the hottest modified and superbly efficient to make stock motors really fly. Quick release 48 D.P. gears

give fast simple ratio changes and smooth reliable drive. The new front suspension has a unique rake angle adjustment system and offers easy assembly and maintenance. CAD-CAM designed suspension geometry gives the COUGAR unbeatable handling over the roughest off-road tracks. Coil over oil shock units manufactured from high quality alloy are used all round for the best off-road performance. The COUGAR uses Schumacher high density mini spike tires molded in the secret "Blue" compound natural rubber, to give you the racing edge. The body has the tough look of a real off-road racer. The alloy chassis is a close fit inside the body to keep out the dirt.

Performance and Technology you can buy.

Available April, 1990 by Trinity Products.

BIGGEST NEWS IN 1/8 SCALE SINCE THE 4WD!

The advent of the 4WD car was received as a mixed blessing by the 1/8 scale racing community. The car certainly handled better than its 2WD counterpart but became a mechanical nightmare by comparison.

The biggest problem lies in the front wheel drive system. Hit a wall and you are likely to lose a front dogbone. Several companies have tried to improve the situation with universal joints, larger dogbones, etc., but crashes still result in broken or bent front end drive components.

Rochelle Racing Products (RRP) has the answer to that problem! While the basic system has
(Continued on Page 19)

CAPPED TIRES FOR:

- RC-10 Rear: #0090
- Dominator: #0092
- 1/10 scale fronts: #0095 soft, #0999 firm
- 1/10 scale rears: #0096 soft, #1000 firm



THE LEADER IN RUBBER CAPPED R/C TIRES!

We've got'em! The hottest new item in R/C racing tire technology — Rubber capped foam tires from CKW! Six of ten drivers at the 1989 Thunderdrome rode CKW's to victory — Find out why they're the winning choice in capped racing tires!

- Pre-scuffed and ready to run
- Chunk-resistant foam centers
- Less prone to "blowouts"
- Strong, rigid rims; less flex, less distortion in cornering.



1889 W. Commonwealth, Unit #1 • Fullerton, CA 92633
(714) 738-1312 • FAX (714) 738-1328

Made in the U.S.A.

(Continued from Page 10)

this process as well. Sometimes we don't like where our Regionals are being held, but it is important we understand what the Region Director is faced with when making his decision. Believe me, it is never an easy process nor one where you can please everyone.

The following outline is one we have used to help clubs and promoters bidding on Nationals and one I have also used here in Region 3. These are just suggestions but I think you can see where this information is important and can be quite helpful.

INFORMATION OUTLINE FOR ROAR NATIONAL EVENT

The following is an outline of information needed by ROAR's Executive Committee when considering a host for a ROAR National Championship. Please provide the following information as completely as possible, so

as we may give your request the proper consideration it deserves. Please feel free to expand on any information you feel will enhance your position or qualifications.

REQUIRED INFORMATION

1. Club Background

- A. Age of club
- B. Number of active members
- C. Club scale interests and activities
- D. Number of members committed to help

2. Experience

A. Level 2, 3, & 4 races held by club (give dates & approximate number of entries)

B. Major races your club plans on hosting this year

C. Major races attended by persons who will run the race you are requesting

3. Race Information

- A. Proposed location
- B. Equipment available

- C. Proposed body types
- D. Entry fee, deadline and entry limit proposed
- E. Date and time table proposed for race

4. Miscellaneous

A. Sponsors:

- a. Local
- b. Major
- c. Exclusive

B. Motel accommodations and location from track

C. Food centers available

D. Family attractions available

E. Motor home parking available

Please try to be complete in providing the information requested. If you have any questions regarding the proposal, please call your regional director or the appropriate scale director. If your club does not own or have access to the required automatic lap counter or the appropriate tech equipment, you can rent items from ROAR.



PARAGON
Racing
MOTORS

For catalog send \$2.00 to: **Paragon Racing Products Dept. CP**
690 Industrial Circle So. • Shakopee, MN • 55379 • (612) 496-0091 • Fax # (612) 496-0191



Jim Halsey

Jay Halsey

Cliff Lett

Mike Reedy

Butch Kloeber

The Hot Tip from Hot Racers

When a solder joint can make the difference between TQ and DNF, you find America's top racers using only the best soldering equipment: Ungar's Super Race Station. Its incredible power not only makes soldering easier and faster, but makes joints flow better for greater reliability and lower resistance. And the quick transfer of heat will protect your sensitive race-ready batteries.

Secrets revealed

The key to the *Super Race Station's* incredible performance lies in its sophisticated electronics. Unlike conventional irons that have a fixed output rated in watts, the Ungar unit has an automatic variable output that keeps the iron tip at any temperature you select, all the way from a mild 400 degrees for precision work to a blistering 800 degrees.

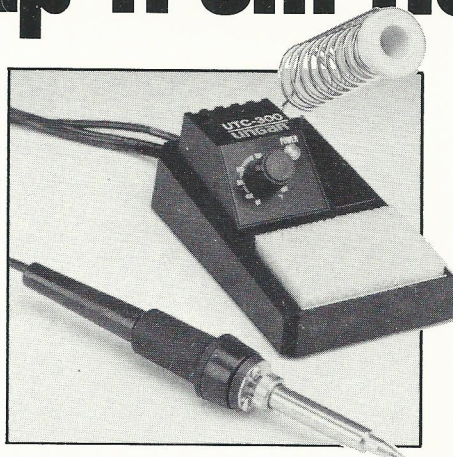

The handy stand keeps the iron safely out of the way of car components in your pit area. Sponge helps keep a clean tip for the extra strong solder joints.



Unlike any other solder station, the Race Station comes equipped with a high mass thermal thrust tip that's perfect for R/C use.

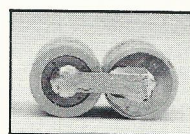

Incredible output allows solder to flow all the way across this battery braid in seconds.

In fact, the *Race Station* has so much power that most racers adjust their temperature controls to about the 750 degree point.

You can buy the same unit

The pros you see use a stock *Race Station*, just like the one you can buy at your local hobby store or race track. Retailing at just \$119.95 for the *Super Race Station*, or \$109.95 for the smaller handled *Race Station*, they're an investment that will pay off handsomely... in better solder joints, and more TQ runs.

UNGAR®

The Hottest Tip in Racing

Exclusively distributed to your local shop through Horizon Hobby Distributors, Inc.

UFRA® "BLACK DOTS" COME TO INDY!

THE ULTIMATE IN
PROFESSIONAL QUALITY
RACING TIRES

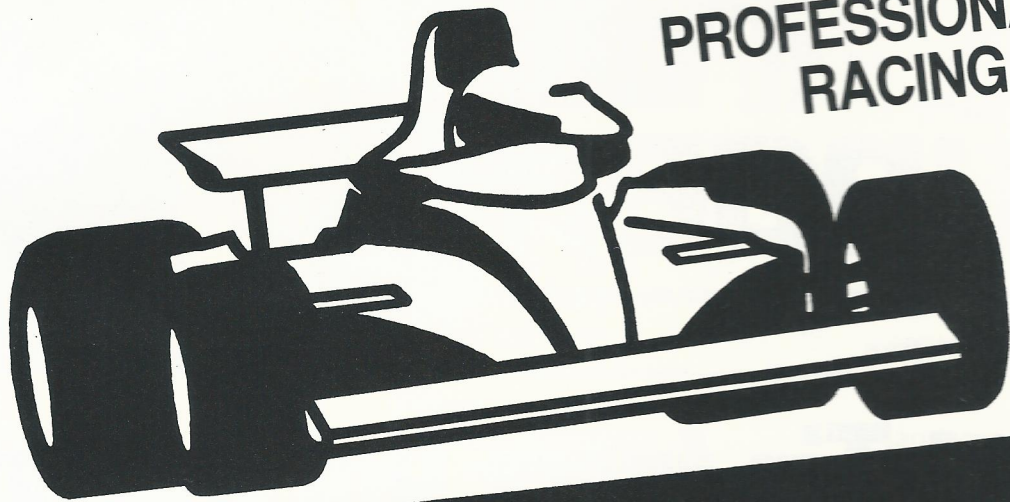

UFRA® is the ultimate professional quality racing tire made of a revolutionary superior natural sponge rubber compound imported exclusively from Switzerland's UFRA® MODELLISMO by Twinn-K of Indianapolis.

- 1/8, 1/10, 1/12 AND SLOT SIZES ARE AVAILABLE AS "BLACK DOTS" AND "BLACK DOT FOOTPRINTS"
- EXCEPTIONAL LONG-LASTING WEAR
- LOWER ROLLING RESISTANCE - HIGHER SPEEDS
- PRECISION TRUED HOLDING POWER - NO TIRE "HOP"
- EDGE RADIUS PRACTICALLY ELIMINATES CHUNKING
- MAXIMUM TRACTION ON CONCRETE, ASPHALT, CARPET, DIRT AND CLAY
- ENDORSED BY NATIONALLY RATED DRIVERS

IF UNAVAILABLE LOCALLY,
CALL TWINN-K FOR PRICE & DELIVERY INFORMATION
SEND \$2.00 TO TWINN-K FOR 1990 PRODUCT CATALOG

TWINN-K INC.

"MAKE THE INDY CONNECTION"

SCALE MODEL RACING TIRES & ACCESSORIES FOR CARS, PLANES & BOATS
TWINN-K, INC. • P.O. BOX 31228 • INDIANAPOLIS, IN 46231 • TELEPHONE: 317-839-6579 • FAX: 317-839-8928

(Continued from Page 15)

been tried before, the ultimate solution was developed by a Cornell engineer in the form of the all new "RRP Slipper Drive" (Patent Pending). Never again will you damage or lose another dogbone - We guarantee it!

The first application is for the Associated RC-500 car. It is a complete retrofit package which installs in less than an hour with no special tools. It fits both stock and aftermarket front bulkheads and adds no additional weight to the car! As an added bonus, the RRP Slipper Drive significantly improves steering response by controlling excessive front wheel-spin in high power cornering situations.

For the ultimate in "bullet-proof" front ends, the RRP Slipper Drive may be combined with the new RRP Steering Block assemblies. Never again will you strip the steering arm bolts out of the stock steering blocks (Note: The RRP Steering Blocks can be used only with the Slipper Drive).

Extensive testing was carried out during the 1989 season by leading Sportsman and Open class racers with outstanding results. The products are thoroughly proven, completely debugged, and ready for distribution im-

mediately. If you are interest in purchasing these products or would like more information, please contact us at: Rochelle Racing Products, 26 West Passaic Street, Rochelle Park, NJ 07662 Phone 201-845-8015 Fax 201-845-5824.

□
**1990 ROAR 4 CELL
MODIFIED NATIONAL
RESULTS**

- 1st - Rick Hohwart
- 2nd - Chris Doseck
- 3rd - Joel Johnson
- 4th - Louis LeBlanc
- 5th - Mike Blackstock
- 6th - Bill Jeric
- 7th - Joe Lawrence
- 8th - Bob Light
- 9th - Bob Schoenau
- 10th - Scott Smith

□
**JOEL "MAGIC" JOHNSON
TAKES TRIPLE CROWN**

Team Triad's Joel "Magic" Johnson with his outstanding performance and his combined points total, is the proud holder of the Sanyo 1/12 scale Triple Crown title for 1989-90.

Joel's consistent performance at the Indoor Champs (3rd), and the 4 Cell Nationals (3rd), combined with a devastating victory at the Winter Championships allowed Joel to arise victorious

and be crowned King of the most coveted title.

Joel again used Trinity horsepower (#1712 "Torkzilla"), Trinity Pushed Batteries and TRC green dot tires to bring him to the winner's circle. Joel regulated this power by using the latest Corally MMS High Frequency Electronic Speed Control and the Corally SP-12 car.

□
**MRC AWARDS TOP PRIZE TO
DRIVER DEREK FURUTANI
AT LOS ANGELES MODEL
HOBBY SHOW!**

The most prestigious drivers in America recently competed in the Second Annual International Race of Champions held at the L.A. Model Hobby Show in Pomona, CA on March 10 and 11. Each driver was equipped with an MRC/Tamiya Astute 2WD Off-Road Buggy. With top caliber drivers participating in this event, which included a wild jump over a criss-cross track, it turned out to be a duel right down to the wire.

Derek Furutani of Peak Performance, who this year captured First Place at the Reedy Race of Champions, once again turned out to be the top dog at this event. Derek walked away with the \$3,000 first prize donated by

LETHAL WEAPON

IT'S HERE!

RUN FOR YOUR LIVES!!

WE'RE ALL DOOMED!!!

NEW FROM... ASL

REPLACES ALL RC-10 AND ULTIMA TRANNYS
ASL MANUFACTURING
P.O. BOX 2115 telephone...
CORONA, CA 91719 (714)735-5249

R. Houck



76.98 MPH IN 132 FT.!

WORLD'S FASTEST 10TH SCALE ELECTRIC MOTOR!

FROM 0 TO 76.98 MPH IN 132 FT!

West Palm Beach, FL — Drag racer Ron Ratoff used a **TWISTER #2001** motor to become the World's Fastest 10th scale electric driver with an incredible 76.98 mph run in a recent Top Fuel event. Ron was officially clocked on professional NHRA-style Chrondek clocks which have also timed him with a mind-boggling 1.91 ET in practice runs! Congratulations Ron!

KRIS MOORE DEVASTATES HAWAIIAN OPEN

Honolulu, HI — TEAM TWISTER blew through our 50th state like a hurricane. And when the devastation was over, Kris Moore had used two powerful combinations to take both the 2WD and 4WD classes. In 2WD Kris made the most of his hot **TWISTER #1002** motor, while in 4WD it was a **TWISTER #501** that powered him to a runaway victory. Naturally, Kris used **TWISTER #105 SCE Matched Batteries** to ensure he had plenty of power to finish what he started.

TWISTER SWEEPS THROUGH NORRCA OVAL NATL'S

Bakersfield, CA — New TEAM TWISTER member Brian Landgraff got off to a great start as he, his **TWISTER #2003** Motor and #105 SCE Matched Batteries blew away the 4WD competition at the 1989 NORRCA Oval Nationals. In 2WD, Eddie Knoles Jr. used his **TWISTER #702** Motor and #105 SCE Matched Batteries to dominate over the country's 2WD oval specialists.

MAGRUDER REIGNS OVER MIDWESTERN OVAL CHAMPS

Oklahoma City, OK — Privateer Nathan Magruder needed an "Unfair Advantage" to beat the factory drivers at the Midwestern Oval Champs. And he got it! Using a store-bought **TWISTER #2003** Motor and #105 SCE Matched Batteries he went out and put the big guns away in 4WD with an incredible display of power and driving talent. **TWISTER** welcomes Nathan to "The Unfair Advantage"!

TWISTER RIPS THROUGH WINE COUNTRY

Sonoma, CA — The peace and splendor of California's magnificent wine country were shattered by Team Twister. At the Region 6 Oval Championships, Brian Landgraff TQ'd, set a new track record, and won the 4WD class going away. In 2WD, it was vintage Eddie Knoles Jr. as he and his **TWISTER #702** blew the competition back into the vineyards. And in the Spring Car class, Jimmy Gouge took a solid TQ, powered by his **TWISTER #2004**. The Region may never be the same.

DREYFUSS DOMINATES MONSTER TRUCKS

Las Vegas, NV — Brandy Dreyfuss used a hot **TWISTER #202** to run away from a hungry Monster Truck field in the 1st Annual Las Vegas Race.

TWISTER'S NEW "POCKET ROCKETS"

TWISTER'S "POCKET ROCKETS" are a hot new line of sportsman motors designed to help keep costs down and performance up. On the street or track, POCKET ROCKETS will keep you ahead of the competition! Pocket Rockets are ROAR and NORRCA legal for Modified Class.

- #3001 — 17T-Bushing 4WD Offroad — \$28
- #3002 — 20T-Bushing 2WD Offroad — \$28
- #3003 — 15T-Bearing 4WD Offroad — \$45
- #3004 — 19T-Bearing 2WD Offroad — \$45

FREE TWISTER "R/C MOTOR TUNING GUIDE"

TWISTER'S new "R/C MOTOR TUNING GUIDE" is available FREE. It details the care and tuning of the electric R/C car motors with tips to help you get maximum performance and long life from ANY R/C motor. To get your copy, or just for tuning assistance, call the TWISTER MOTOR HOTLINE NUMBER: 818-914-6177, write us, or stop by our shop at 657 E. Arrow Highway, Suite H, Glendora, CA 91740.

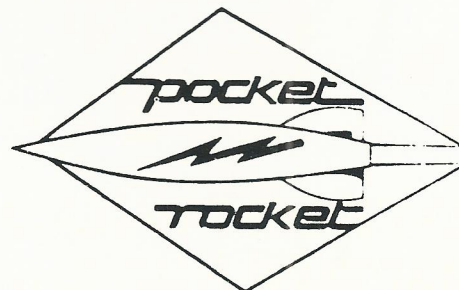

Model Rectifier Corporation. Furutani's winning speed averaged 16.22 seconds per lap at the show's 50 ft. x 60 ft. custom built dirt track.

Peak Performance's own Rick Hohwart captured second place with an average time of 16.37 seconds per lap. Rick, who has a list of wins under his belt, was awarded a \$500 prize also donated by MRC.

A total of 60 drivers competed, representing more than 30 manufacturers exhibiting at the show. Each team built their Astute buggy, "one of the hottest off-road cars to hit the market in a long time," according to Frank Ritota, Vice President of Sales for MRC.

The track was designed by Tamra Heppert of Metro Fast Raceway, Hanover Park, Illinois. It was crewed throughout the races by Joe and Laurie Dubay

of Sunkist R/C Park in Barstow, CA.

A new lap counting system and the Count R/C race management software was provided by Dave Delage of MIFCO Precision Racing Measurement, Portsmouth, NH.

A \$300 prize was awarded to third place finisher Curtis Strawn, Superior Racing, who averaged 16.85. The fourth place prize, an MRC King Cab Truck Kit, went to Race Prep's Steve Dunn, averaging 17.07. The fifth fastest racer, RC Race Center's John H. Smith, received \$50 for his average speed of 18.08.

The Los Angeles Model Hobby Show is sponsored by the Radio Control Hobby Trade Association (RCHTA) and co-sponsored by the Model Railroad Industry Association (MRIA).

The next race in the series will be held at the Philadelphia

Model Hobby Show, Philadelphia Civic Center, May 3-6, 1990.

PRO-LINE WINS IN 1990

ROAR Monster Truck Nationals March 2, 3, 4, 1990, Las Vegas, Nevada. Scott Montgomery - A Main, 2WD Stock, 8th Place; Wylder Barrows - B Main, 2WD Stock, 1st Place; Tim Clark - B Main, 2WD Stock, 5th Place. Products used-Pro-Line Monster Truck Conversion Kit. Tires-Race Engineered Design PRO - 40, #7040 2.2" Rear, PRO - 45, #7045 2.2" Front. Wheels - #2526 Front and #2528 Rear. Body - Nissan Hardbody Racing Truck Body #3003.

JOE AND PEAK TAKE REGION 3

Peak Performance driver Joe Lawrence won the Region 3 1/12 Scale 4-Cell Championships in March with his Peak Performance powered Agitator.

TO FINISH FIRST, FIRST YOU HAVE TO FINISH!

- We do our own injection molding and control the quality. Every gear we sell is round and concentric, so the gears mesh is easy to adjust.

- They are molded from high temperature Teflon lubricated virgin nylon, to last longer and run friction free.

- The 12 ball bearing hole circle and Teflon lubrication make it easy to get a free running differential adjustment, so your car gets more tire bite when powering out of the corners. Our gears can be purchased with or without 12 ball bearings pre-installed.

available through dealers & distributors

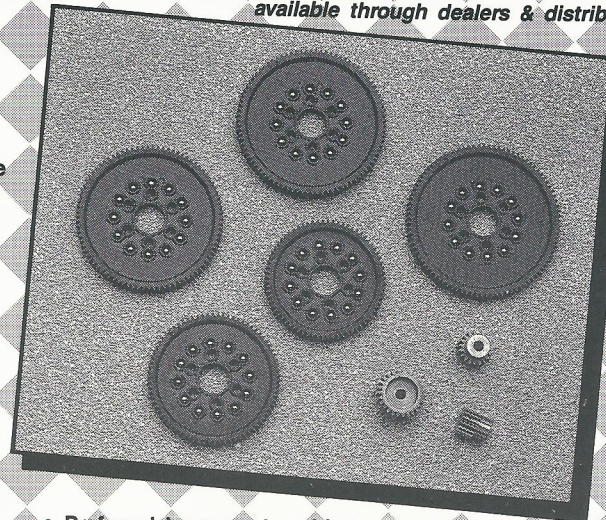

- Preferred by many top drivers & teams.
- 48 pitch pinion gears for 1/12 & 1/10 scale RC cars. Precision machined.
- KP to Mid optima gear adaptors.
- KP to JRX2 gear adaptors.

Kimbrough Servo Saver's Choice
of World Champion's to Club Racers

KIMBROUGH PRODUCTS

1420 East St. Andrew Pl., Unit F • Santa Ana, CA 92705 • FAX (714) 557-4609



ONLY

HI-IQ

CAN UNLEASH THE DEMON IN YOUR NI-CAD

BY PRECISION CHARGE, DISCHARGE, CYCLING,
GRADING/MATCHING, AND MORE.

• MICRO-COMPUTER STRUCTURE.

EXTREMELY USER FRIENDLY.

NO NEED TO READ MANUAL for most functions

even first time used

• socketed EPROM I.C. for easy do-it-yourself software version exchange

• EXPANDABLE - two piggyback modules** - to be announced:

1) AC to DC Converter to allow use of AC house current

2) MULTI-FUNCTION MODULE to allow hook-up and auto-switching of up to 8 packs, cell equalizing without splitting packs, serial port for printer or host PC interface, tachometer, dynamometer, lap counting and more

• DIGITAL KEY PAD for function selection and data entry. NO OTHER SWITCHES OR CONTROLS

CAUTION! HEAT SINK AND CASE MAY BECOME VERY HOT

• HEFTY HEAT SINK for VERY HIGH POWER CAPACITY

• POWER INPUT (reversed polarity protected) - car or motorcycle battery or suitable power supply

• DIGITAL VOLTMETER probes. Also for remote volt sensing during test-discharge for increased accuracy

• THERMAL PROBE** can be connected to METER for Thermal Charge*, THERMOMETER* function & COOL-OFF auto cut-off

• MOTOR CURRENT TEST up to 30A cont. / 100A peak for fine tuning of gears (props), bearings and commutators
• new MOTOR / GEAR BREAK-IN cycling

• STOP WATCH function*

• Motor SPEED CONTROL EFFICIENCY TEST - volt. drop @ 10A load (finally reliable proof your VICTOR S/C is the best)

• True ALPHANUMERIC DISPLAY guides you by MENUS WITHOUT READING MANUAL. Very friendly machine.

• Continuous display of Amps, Volts, time, mAh during functions

• Plain language messages (no codes)

• CARRYING HANDLE / SLANT STAND

• 1 - 8 cells - reversed polarity protected - all parameters selectable in fine increments

• Peak-, time-, thermal CHARGE
• Precision constant current DISCHARGE

• AUTO-CYCLING up to 99 cyc.

• computerized GRADING / MATCHING / TESTING

• AUTOMATIC PEAK MAINTAINING* - keeps pack warmed up (1 hr max.)

• dead cell revival*

* OPTIONAL SOFTWARE

** OPTIONAL HARDWARE & SOFTWARE



380 Camino de Estrella, Suite 170
San Clemente, CA 92672
Phone (714) 496-9701

Monday - Friday 9 a.m. to 5 p.m. PST
- Phone or write for more information.

PIT TALK

By J. R. Sitman

Well here we are into the 90s and already the racing calendar is jam-packed with events. At the time of this writing, we have already completed almost a dozen races (On-road, dirt oval, and off-road events) and it's only the third month of the year! Eight races were held in California, one in Massachusetts, one in Virginia and one in Texas.

At the first off-road race of the Winter Series, some of the drivers signing up expressed some confusion about NORRCA's new way of splitting up the classes into two groups; Expert and Sportsman. Here are a few general tips to help you decide which way to sign up. If you have placed in the top ten at NORRCA or ROAR National events, then you automatically rate as an Expert. Experts are not allowed to race in the Stock or Novice classes. You may enter any way you want, but once you enter Expert, you can't go back to Sportsman that season. You may move up from Sportsman to Expert any time but if you do it midway through the season, you probably won't accrue enough points to place in the top ten. NORRCA won't bump anyone up from Novice to Stock or Sportsman to Expert during a season. You can contact J.R. Sitman for more detailed info. at (714) 981-9641. J.R. admits that the formula is not 100% perfect, but so far it has been working out very well and it might take a short while to iron out any kinks. It has worked out so well, in fact, that the Novice classes have doubled since last year and J.R. credits this new system for that.

NORRCA prides itself on being a race sanctioning body that is run by racers (not manufacturers) for racers and proves that fact by its innovative ideas. One of NORRCA's new ideas is to offer racers 12 years of age and younger the opportunity to purchase a year's membership for half the regular price in order to promote the "family oriented" aspect of this hobby/sport. Under 12 drivers pay only \$10.00 instead of the normal \$20.00.

The dates and locations for this year's National events have been set so mark your calendars with the following: PAVEMENT ROAD COURSE NATIONALS, June 1-3, Racer's Haven, Bakersfield. OFF-ROAD NATS, July 6-8, Norm's R/C Hobbies, Dallas, TX. DIRT OVAL NATS, August 17-19, Cooper's R/C Center, Chatham, VA. PAVEMENT OVAL NATS, Cajon R/C Speedway, Cajon, CA.

Some questions have been raised on how NORRCA decides on the locations for National events. NORRCA relies on the expertise of seven individuals (whom will remain anonymous), who are heavily involved with the sport and are NOT manufacturers to vote on sites using a points system. Each voter is given a list of things to consider (Hotels available, pit space, snack bar at the tracks, other attractions near the sites for family members, etc.) and are asked to rate each one with points from one to ten. NORRCA simply tabulates the scores then makes a decision. NORRCA favors

the racers and their families only in its choices and does not favor any particular racetrack.

I am personally a real concourse nut and therefore could imagine the disappointment one unlucky racer must have felt at a recent event. NORRCA has revived its "running concourse" rule, requiring concourse winners to run their award winning bodies in at least one of the heats at the event that their entry is placed in. Apparently this particular racer was unaware that he was supposed to run his body and during the main events a protest was lodged by another entrant and he was subsequently disqualified. Tough break but at least he is still eligible to enter in any subsequent event. Also, remember that driver figures inside of cars gain you more points during judging. You may remove driver figures and those expensive wheels you might have for the race but you must RUN THAT BODY!

Well that's it for now so farewell till next time and beware of the backmarkers... they'll take you out!

□CP

Leading Edge R/C Racing Products

Battery Power To Win
\$\$ PRICED TO SELL \$\$
Sanyo - Lavco Matched

SCES		SCRs	
Lavco #	\$/Cell	Lavco #	\$/Cell
680+	10.00	490+	9.00
660-679	8.50	480-489	7.50
650-659	7.00	470-479	7.00
640	6.00	460	6.00

Available At
Action Pro Shop
(313) 283-8322

or
See Your Local
Hobby Dealer

• Dealer Inquiries Invited •

Leading Edge - 3224 Fourth Street, Wyandotte, MI 48192



HobbyShopper's Guide



R/C MODEL RACE CARS
1/10, 1/8, 1/12 scale
Electric, Gas

KIT CAR

"WE RACE WHAT WE SELL"

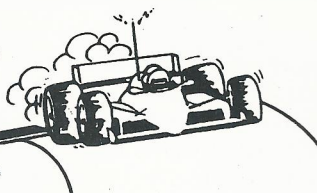

Specializing in complete racing units and parts.

Dave Bressel (503)256-9916 Shop/Mail Order
Byron. Bressel 12010 NE Glisan, Portland, OR 97220

Radio Control - Plastic Kits - Crafts - Model Railroading



COMPLETE LINE OF R/C RACE CARS & ACCESSORIES
903 FAIRYLAND ROAD
ACROSS FROM FRANKLIN TOWNSHIP BUILDING
LEHIGHTON, PENNSYLVANIA 18235
(215) 377-2402

Lake Side HOBBY SHOP



Specializing in R/C Cars
large stock of accessories!

BENEFIT FROM THE EXPERIENCED RACERS!!

We ship UPS 13737 N DALE MABRY
LAKE SIDE CENTER
TAMPA, FLA 33618
PHONE (813) 961-9432

major credit cards accepted



WALT'S
HOBBY

Full line radio control hobby shop specializing in friendly, helpful service for remote control cars, parts and accessories. Daily UPS Service. Discount Prices. Visa, Master Card, American Express. Home of the indoor clay oval and computerized scoring.

"CALL WALT'S"

Tel. (315) 453-2291

2 Dwight Park Dr.
Syracuse, NY 13209

BUFFALO, NY

When Visiting Niagara Falls - Visit Us Too
I-90 Thruway Exit 52 E (Near Galleria Mall)

Niagara

Hobby & Craft Mart

3366 Union Rd. (at Walden), Buffalo, New York 14225

R/C Cars - Parts & Accessories

Our OVAL BLACKTOP R/C Track Open Saturdays & Sundays

716-681-1666

OPEN EVENINGS
AND SUNDAY

RC

PIT STOP

#14-6822 128th St., Surrey, B.C. V3W 4C9

Radio Controlled Models
Cars, Parts and Accessories

WES TURNBULL

(604) 597-4670

HobbyTown

Where your dreams live*

NEBRASKA		Colorado Springs	719-531-0404
Lincoln	402-483-7427	CALIFORNIA	
Lincoln	402-464-2858	Encinitas	619-942-2014
Lincoln	402-476-3829	Escondido	619-739-0672
Omaha	402-391-5669	OHIO	
Bellevue	402-291-0542	Cincinnati	513-793-5112
Grand Island	308-382-3451	VIRGINIA	
Scottsbluff	308-635-7001	Centreville	703-818-3069
COLORADO		Manassas	703-551-2700
Fort Collins	303-224-5445	ARIZONA	
Denver	303-431-0482	Scottsdale	602-948-3946

** CALL FOR LOCAL INDOOR AND OUTDOOR RACE TIMES **
YOU CAN OWN YOUR OWN STORE JUST CALL 402-467-4784



STRONGSVILLE HOBBY SHOP

NORTH COAST R/C MAIL ORDER HEADQUARTERS
CALL FOR MAIL ORDER SPECIALS

13325 PROSPECT ROAD
STRONGSVILLE, OH 44136
216-572-0430

JERRY IVANCIC

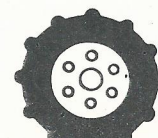
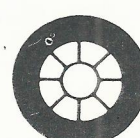
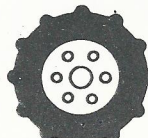
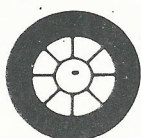
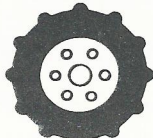

HobbyShopper's Guide

1/10 and 1/12 Scale Electric

PARTS AND ACCESSORIES

Modeler's Haven



NEW STAGE III BATTERIES
SCE RATING 630 AND UP
SCR RATING 450-510
CALL FOR PRICES
ALSO COMPUTER MATCHED GONZOS

PROMPT SAME DAY
U.P.S. SHIPPING
(218) 499-6000

4255 Portage St. N. W.
North Canton, OH
44720

VISA AND MASTERCARD ACCEPTED

ROAR OFF-ROAD CHAMPIONS
FLORIDA STATE CHAMPIONS

CENTRAL FLA. HOBBIES, INC.

5600 W. Colonial Dr., Suite 311
Orlando, FL 32808

Glenn Harkey
Sharon Harkey
(407) 295-9256

Discount Prices
UPS Service
Major Credit Cards Accepted

RACEWAY HOBBIES

Complete RC Connection
RC Supplies & Track

(407) 468-4338
Terry • Lou • Bill



"Come Race With Us"

Lexington Shoppes • 6845 So. U.S. 1 • Port St. Lucie, FL 34952

THIS SPACE IS AVAILABLE FOR
YOUR HOBBY SHOP'S
LISTING
CALL FOR INFORMATION
and RATE (714) 846-0403

Action PRO SHOP



The R/C Car Specialist

20% Discount on All Parts
Lowest Prices On:
Car Kits
Electronics, etc.
We Will Ship COD

MOTORS &
BATTERIES
30% Off

Vince Palazzolo, Owner

3224 FOURTH • WYANDOTTE, MI 48192 • (313) 283-8322



(718) 389-4485



THE HOBBY PRO SHOP
Specializing in Radio Control



ALL NAME-BRAND MERCHANDISE,
CALL OR STOP IN FOR EVERYDAY LOW PRICES.



476 Humboldt St.
Brooklyn, N.Y. 11211



"WE RACE WHAT WE SELL"

Prescriptions Available - Performance Proven



Quality Lenses Are The Winning Edge
Visa & Mastercard

P. O. Box 25943
Tamarac, FL 33320

Dealers Call
(305) 572-8927



You Break - We Fix
Over 100 Companies Stocked
WE DISCOUNT EVERYTHING
If We Don't Have It - We Can Get It!

R & W Inc.
HOBBIES & CRAFTS

Authorized Ace and Futaba Dealer
Full Service Department - Home of Teddy's R/C Raceway
430 Shoemaker St., Swoyersville, PA 18704,
(717) 283-3066

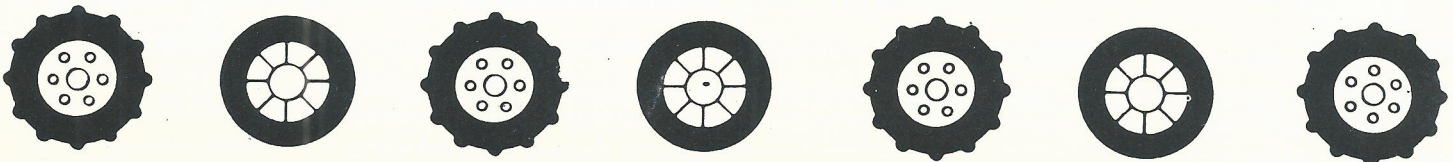

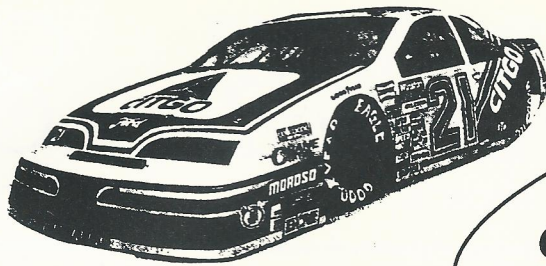

R/C SUPERDROME[®] San Diego, CA.



PRESENTS THE

1st Annual WESTERN HIGH BANKED Oval Speedway

July 2,3,4 Fourth of July!

30° Banks, 1075 Feet Long,

Biggest in the west

Speeds over 70 MPH!!!

- 1/10 Scale Stock Car Bodies
- Sportsmen and Invitational Classes*
- Expert Class Super Speedway Enduro and Insane Speed Run!
- Tune Up For **THE THUNDERDROME!**

SPONSORED BY

- Reedy • Advanced • Hobbytown • Novak • E&L • Tekin • Hobby shack
- Cheetah • Collins Label • R/C Innovations • Sign Art • Paragon • Trinity
- R/C News • Buds • Race Case • CKW • Robinson • Tsunami • Revtech
- Sir Speedy Printers-Kearny Mesa • OBR • Competition Plus • Andes •

ENTRY FORM

SPORTSMEN

- Direct Drive Stock (Nascar/Asa Bodies) 6 Cell, Handout Motors, 4 minutes
- Direct Drive Modified (Winston Cup Bodies) 7 Cell, Modified Motor, 4 Minutes
- Gearcase Modified (Nascar/Asa Bodies) 7 Cell, Modified Motor, 4 Minutes
- 1/12 Scale Modified (Nascar Bodies) Modified Motors, 5 Minutes

EXPERT

- Direct Drive Modified 7 Cell, Modified Motor, 4 Minutes
- Superspeedway Enduro 7 Cell, Modified Motors
- Insane Run (Electric) Anything You Can Fit Under A 1/10th Nascar Body.

Name: _____

Address: _____

Phone No.: _____

Sportsmen Class Expert Class

Frequency 1. _____ 2. _____ 3. _____

GENERAL INFORMATION

Dates: July 2, 3, 4
Sportsmen Class: Entry Fee \$ 40.00 Modified Classes \$40 Stock Class With Handout Motor

Sportsmen Entries Limited To 200
(One Entry Per Person)

Expert Class: Any R/C Industry MFG. Interested In Participating In The Expert Class With Racers Or Sponsorship, Please Contact San Diego R/C Superdrome
(619) 278-1491

Entry Fee \$40.00 All Pro Classes

Make Check Payable To: San Diego R/C Superdrome

Mail Check & Entry To: San Diego R/C Superdrome
2551 Cornstock St.
San Diego, CA 92111

Note: All Entrants Must Be A ROAR or NORRCA Member.

NR/CTPA

By Dave Sproul

WHAT IS THE NR/CTPA?

The National Radio Control Truck Pulling Association (NR/CTPA) was formed as a nonprofit organization in August of 1987. Dedicated to promoting R/C pulling and monster truck competitions, the NR/CTPA has established affiliated clubs and sanctioned events around the U.S.

WHERE DID THE NR/CTPA BEGIN?

The NR/CTPA was created by a group of R/C enthusiasts in Pittsburgh, Pennsylvania who had a desire to compete in R/C pulling competitions and saw the need for a national governing body. In May, 1989 the NR/CTPA office moved to its present location in the Midwest.

WHAT DOES THE NR/CTPA DO?

The Association provides rules

and guidelines for pulling and monster truck competition, sanctions local, regional, and national events, and publishes R/C Puller. In addition to the above, the NR/CTPA works with various manufacturers to produce specialty products for pulling. The Association also promotes the Annual World Championship Truck Pull which in 1989 drew 183 entries from three countries and over 1000 spectators.

WHO ARE THE MEMBERS?

NR/CTPA members come from all walks of life and live in various locations throughout the U.S., Canada, New Zealand, Korea, Greece, Japan, and Puerto Rico.

WHAT DOES

MEMBERSHIP INCLUDE?

Membership includes: NR/CTPA Official Rule Book, membership

card, decal sheet, subscription to R/C Puller, discounts on NR/CTPA shirts, hats, and jackets and reduced entry fees at sanctioned events.

HOW MUCH DOES MEMBERSHIP COST?

Membership dues are \$15.00 per year for U.S. residents and \$25.00 per year for foreign members.

WHAT IS R/C MOTORSPORTS INTERNATIONAL?

RCMI was formed by NR/CTPA in January, 1990. Created as a nonprofit organization, RCMI's primary purpose is to promote and establish R/C pulling and monster events outside the U.S. RCMI also serves as a parent organization to the NR/CTPA.

HOW DO I BECOME A MEMBER?

Simply contact: NR/CTPA
P.O. Box 1488,
Champaign, IL 61824-1488
(217) 586-2597

RACERS *Now available 'Graphite Reinforced Axles' that give your car*

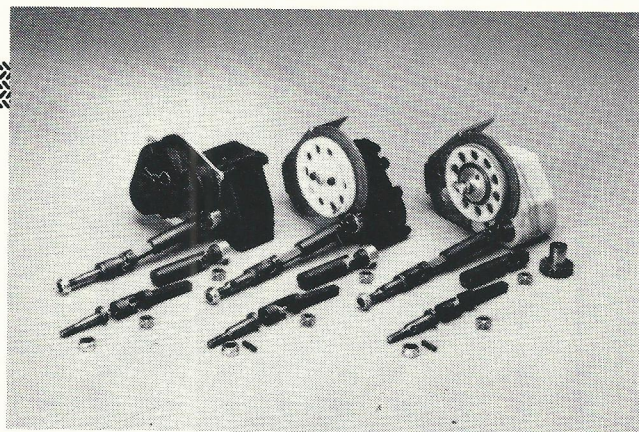

THE EDGE

For.....

*J-Cars, Modified Monster Trucks,
RC-10 & Ultima Racers...
... if you're using Kyosho, MIP,
Associated or Thorp Differentials*

Pavement or Dirt, On-road or off-road, Stock or Modified

*Quiet operation • Reduce drive line wind up • Very light weight • Small 3/8" diameter
Hardened steel stub axles • Available in Nylatron or Graphite*



Custom Scale Components

For more information call: (708) 305-9655 after 5 pm central
or write to: 1807 S. Washington • Suite 363 Naperville, IL 60565



NEWSLINE

12th SCALE INDOOR RACING ON PUGET SOUND

By Terry Graham

The first day was practice day, which quite often turns out to be a free for all at an event this size, however, there was an air of friendly competition which led to an adherence to the rules imposed by SARCAR. Only eight drivers were allowed on the stand at a time with frequency clips on their antennas. They didn't even have to impound radios.

One thing became apparent during practice; the stock class cars were turning in some pretty fast lap times. I checked with Dave Steen (he and his wife Georgia own and operate Race-

way Hobbies) to see which motor had been used as handouts. It turned out to be Trinity's new Signature Series Joel Johnson Stocker. I have personally used this motor in my RC10L for indoor oval track racing and without changing springs or brushes it outperforms other stock motors that I have spent hours dyno-tuning.

With practice day over without a hitch, day two brought the qualifying rounds.

There were a total of 10 qualifying heats; heats 1-7 were modified class with a total of 49 entrants, and heats 8-10 were stock class with 16 entrants. In order to keep things moving as quickly as possible, Georgia Steen grouped drivers into their

qualifying rounds according to their currently know driving ability. This worked well to provide some relatively smooth heats. There were originally only three rounds of qualifying heats scheduled for the day but everything ran so quickly and smoothly that a few of the drivers petitioned for a fourth round. The SARCAR officers held a quick vote and racing continued.

Byron Bressel from Portland, Oregon was the top modified qualifier in the first round, however, Steve Curry from Edmonds, Washington and Bob Stormer all the way from Glasgow, Montana were right there with 29 laps each. The second round was where Bob Stormer was to earn the title of

Keep it cool!

**When the competition is hot...
you have to keep your cool! So
do your brushes and motor.**

For this reason, CLASS Recreational Products designed the new *Venturi* brushes. When installed correctly, the spinning commutator actually creates a vacuum (venturi effect) over the hole in the center of the brush. This venturi effect pulls cool air in from the outside of the motor keeping the commutator and brush tip cooler. Result... less glazing and better commutator life. Look for the CLASS venturi, cut, and full brushes in both stock and modified compounds at your dealer today.

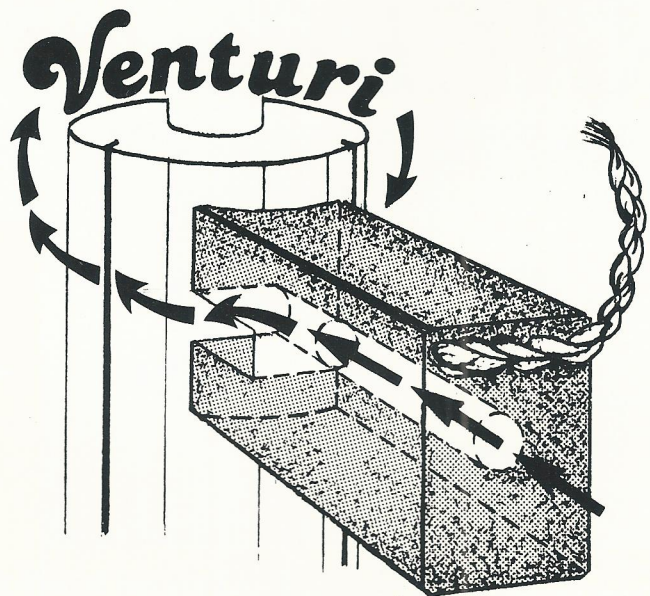

Class Recreational Products
RD #1 Box 187A
Utica, NY 13502
TEL. (315) 724-8052



Top Qualifier in the modified class with a scorching 30 laps in 8:17.16. These three drivers were to hold down the top three spots throughout qualifications. The current SARCAR points leader, Jeff Travelstead of Bothell, Washington, who had run very strong all season qualified sixth attributing his lack of performance to tired batteries and radio problems.

In the stock class, Don Landaker from Salem, Oregon was TQ in the first round with Jon Wadkins and Randy Holst from Beaverton, Oregon right behind. In the second round Randy Stucker from Black Eagle, Montana took over the first spot where he remained turning in 27 laps in 8:12.75 in the 4th round earning himself the TQ award in the stock class. Randy Stucker and Bob Stormer captured TQ in both classes for Stormer Racing.

With qualifications out of the way on Saturday, Sunday was to be full speed ahead racing. This

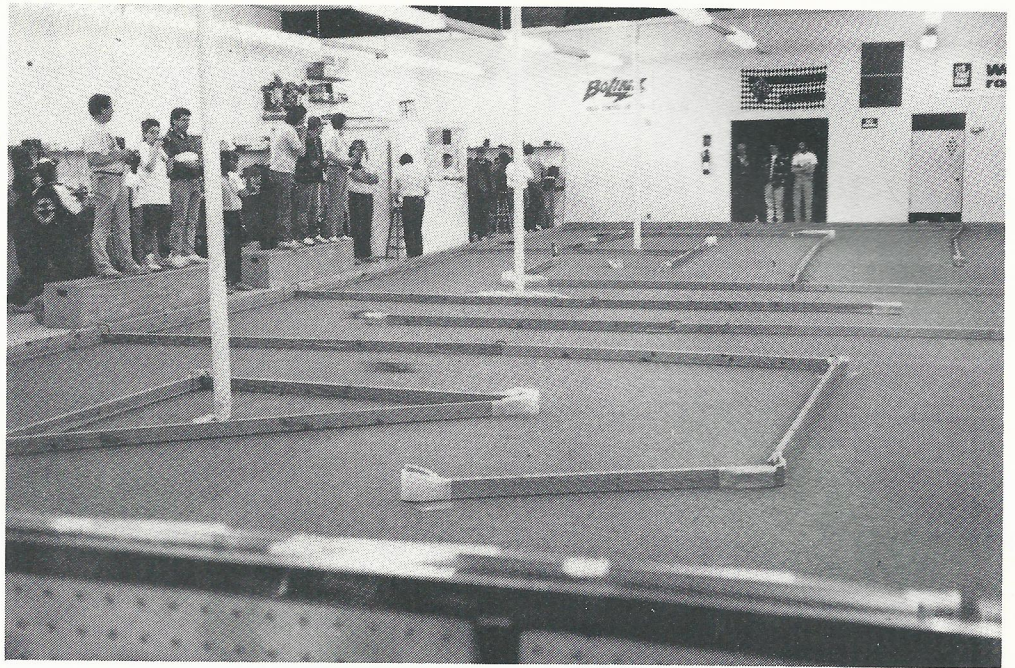

An overall view of the carpet track.

is how it happened. The track opened at 10:00 a.m. Sunday morning and racing began at 11:00. There were six modified events scheduled and two stock events. Racing started with the Modified F main, - only three

cars in this one because the modified field had thinned out to only forty-three cars. You could feel the excitement in the air as each of the mains were run. There was no less tension at the beginning of the F main than

THE FUTURE, NOW!

WITHIN ONE YEAR: Every manufacturer of competitive 10th scale off road cars will introduce transmissions with slipper clutches. They will try to copy different designs and components incorporated in our race proven T.P.S. Chain Drive Transmission with Slipper Clutch. However, these transmissions still won't compete because they will be gear or belt driven with higher rotating mass and more friction (both static and under load).

GET SERIOUS: With a race record to back it up; T.P.S. Transmissions have now won national, regional and state titles in dirt oval and off road championships throughout the U.S.; The competition has to catch up. We are there, and getting further ahead each day.

Winners run T.P.S. Chain Drives, losers run something else.

RC-10 Transmission with Slipper Clutch
#9030S \$129.99

Ultima Transmission with Slipper Clutch
#9031S \$134.99

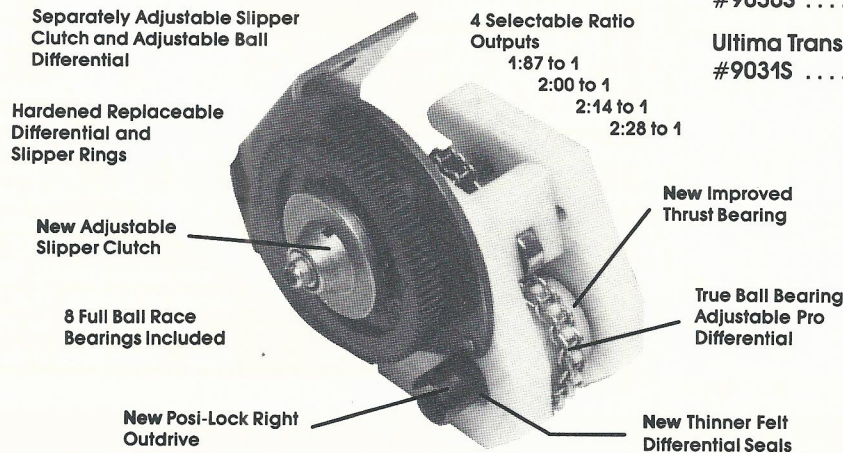

12353 S.W. 132nd Court Miami, Florida 33186
305/255-2887 FAX: 305/255-2970

WARNING: The Surgeon General has determined that this transmission can be hazardous to your competition's health.

TRINITY[®]

RETURN OF THE MAGIC MAN

While Tri-Rex is gone to the land of Bat-Ree to acquire the power known as Pushed from Jo-El the Magician, Son of Gary, the Kingdom of Powurr is under attack.

This is it for you, Gear Gut!

Tri-Rex, grab some Trinity Pushed cells and let's kick some tail.

With Tri-Rex gone, we need power badly.

I don't know how much longer we can hold out.

Once again, Pushed Batteries and the Speedworks Magic Johnson motor make the difference between winning or losing.

These batteries are one reason we always win.

Yes, and they don't call me 'Magic' for nothing.

Blow 'Em Away With Trinity Pushed Batteries

The Triad Heroes use secret "Pushed" cells which are the top 2% that have survived Trinity's special cycling process. This gives them more power for longer, more consistent runs.

The cells in each Pushed battery pack are closely matched and their rating is lettered right on the battery. There is no guesswork. You actually know how many seconds each battery is good for.

The Magic Motor from Speedworks

Jo-El depends on the 25,000 rpm Speedworks Magic Johnson Signature motor. It's the hottest R.D.A.R. stock motor available (#0444). With wet magnets and heatsinks, it's so fast it ought to be illegal. But, it's not!
Trinity... Always Ahead of the Rest

TRINITY Trinity Products, Inc.
1901 E. Linden Ave., #8, Linden, NJ 07036 (201) 862-1705 FAX (201) 862-6875

Want to be a Road Knight? Drop us four bucks and we'll send back a Trinity catalog and a Triad sticker that can make you the local super hero.
Trinity[®], Monster[®], and Monster Horsepower[®] are registered trademarks of Trinity Products Inc. ©1990 - Trinity Products, Inc.

**TRY THIS
WITH ANY
OTHER CHARGER!**

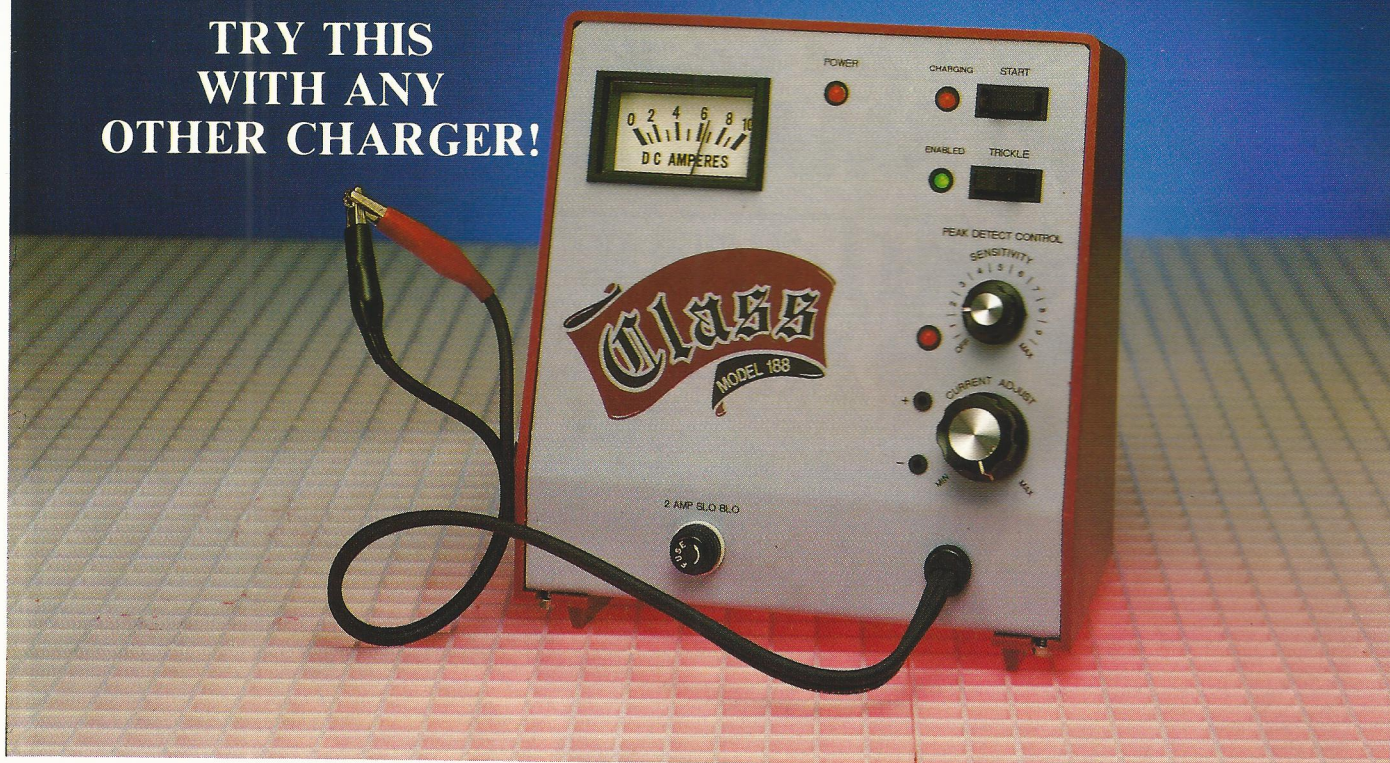

You *WONDER* why Class can offer a one year warranty?

At Class Recreational Products, we believe an important feature of a charging system is durability. We test our chargers by shorting the leads and starting the charging cycle. Our chargers can handle this abuse and we offer a one year warranty to prove it. The MODEL 188 soft pulse charger charges 1 to 8 cells at up to 8 amps and breaks in motors while providing peak detection, peak sensitivity control, and trickle enable/disable.

All of these features come in one small 120 VAC powered package without the need of those costly fans, power supplies or specialized chargers.

The Class MODEL 188 charger is the premier item in a broad line of recreational products built with the same dedication, ingenuity, and product knowledge that go into the design of mini and micro computers.

Here are some comments we've received:

Don Brown of STAGE III, THE ULTIMATE CELL TEST — "We have evaluated and we endorse the Class MODEL 188 charger. The charger is the best AC charger we have seen and tested, it is excellent for indoor racing. No other unit offers all the convenient features of the Class charger."

Bob Light (World Class Driver and National Champ) — "... convenience and performance, it's great!"

Frank Calandra (1989 Speedworks Sportsmans Cup and Region I Champion) — "... No fans, no power supplies, no false peaks, less junk to carry. All this in such a small package! Charge with Class, it works!"

Available from Horizon Hobby Distributors or your local dealer.



Class Recreational Products, Inc.
RD 1, Box 187A
Utica, NY 13502

Telephone (315) 724-8052
FAX (315) 732-2034



TRINITY
WORLD CHAMPIONS

PRESENTS

*Speedworks*TM

SPORTSMAN CUP RACE



JULY 6, 7 & 8 1990

at FREEDOM HILL PARK, STERLING HEIGHTS, MICHIGAN

TRINITY, maker of world champion racing motors and other quality r/c racing products, is pleased to announce the "SPEEDWORKS SPORTSMAN CUP" race. In the true spirit of the sportsman, the same spirit behind the development of the SPEEDWORKS line of motors, this is a race created for the true sportsman driver. Absolutely **NO FACTORY TEAM** drivers will be allowed to participate.

Whether participating in 2WD or 4WD, all racers will receive the same hand-out SPEEDWORKS motor. Both classes

will be for six cell batteries. The 170' x 70' dirt track was designed for the 1989 Roar Nationals and will provide a true test of driving skill. Horsepower will not be the deciding factor! SPEEDWORKS is dedicated to distinguishing the best sportsman driver in North America.

Special seminars will be presented, featuring 10 of the best expert drivers in the country. These talented men will share their race secrets in group and one on one sessions. Special attention will be given to motor care and tuning, chassis set-up, and driving tips.

SPEEDWORKS wants you to learn how to go faster. These same 10 drivers will also compete in a special 10 car event using the same SPEEDWORKS motors used in the "SPORTSMAN CUP". You will see the secrets they have

shared, in action!

If you are truly a sportsman driver, don't miss the 1990 "SPEEDWORKS SPORTSMAN CUP".

ROAR sanction #039044

Name: _____

Address: _____

Phone: _____

Freq. Choice: 1. _____ 2. _____ 3. _____

ROAR No. _____ Entry Fee \$35.00

No. of years driving: _____ T-shirt size: _____

Class: 2WD _____ S M L XL XXL

Class: 4WD _____ Age (optional) _____

All entries are subject to refusal based of Mfr. support/Deadline June 30, 1990

Make checks payable to John Thawley and mail to:

John Thawley / SPORTSMAN CUP / 288 E. Maple #266 / Birmingham, MI 48009



5 National Titles

YOU CAN'T BEAT THE SYSTEM

- **VRP LUBRISYSTEM**, a unique lubricating system featuring VRP's 4 superior lubricants at an economical price!
- **LUBRISPRAY**, the only spray synthetic lubricant designed for R/C car transmissions. We couldn't make it any simpler. Just spray it in . . . and win.
- **LUBRIBEARING**, a new ballbearing grease that goes on thin, seeping into all crevices and other moving parts. The carrier then evaporates leaving behind a thin layer of grease that won't fly out.
- **LUBRITOOTH**, for use on teeth of all gears. Lubritooth is a bonding lubricant that dries quickly forming a permanent lubrication that won't attract dirt.
- **LUBRIDIFF**, a high tech synthetic grease for use on all ball type diffs. Very high traction coefficient allows the diff balls to grip the rings without unnecessary tightening.



4555 Groves Rd. #15 Columbus, Ohio 43232 (614) 861-4555 FAX (614) 861-4050

Available at your local Hobby Shop.
Or call toll free 1-800-783-4VRP
Mon. thru Fri. 9 to 5 Eastern Standard Time

verona racing products

4555 Groves Rd. #15 • Columbus, Ohio 43232
Telephone: 614-861-4555 • Fax 614-861-4050

SASE for Brochure and Tech Tips
add \$2 for decals, add \$10 for T-shirt (size)

FUNTIME R/C RACING

AND

NORRCA

NATIONAL ORGANIZATION FOR RACING RADIO CONTROL AUTOS

PRESENTS

1990 TRI-STATE CARPET OVAL CHALLENGE

JUNE 23RD & 24TH 1990 PORTLAND, MAINE

NORRCA MEMBERSHIP IS REQUIRED * (MEMBERSHIP IS AVAILABLE AT TRACK OR THROUGH NORRCA) * NORRCA RULES APPLY *
NORRCA T.Q. PINS FOR TOP QUALIFIER IN EACH CLASS * CONCOURS TROPHIES * ALL CLASSES MUST RUN AMERICAN STYLE SEDANS
HOTELS, RESTAURANTS AND TURNPIKE WITHIN 1 MILE. LOTS OF PRIZES TO BE AWARDED. STOCK MOTORS SUPPLIED

SCHEDULE: JUNE 22ND OPEN PRACTICE NOON - 9:00PM, JUNE 23RD PRACTICE 8:00 - 9:30 AM, 10:00 AM DIRECT DRIVE HEATS BEGIN
JUNE 24TH 8:00AM - 9:30AM PRACTICE, 10:AM GEAR BOX CLASSES BEGIN. HEATS AND MAINS WILL BE COMPLETED ON THE SAME DAY
AS THE CLASS RUNS. PRE-ENTRIES CLOSE JUNE 16TH. ENTRIES AFTER DEADLINE WILL BE CHARGED AN
ADDITIONAL \$5.00 PER CLASS * MAXIMUM ENTRIES 200 (100 GEAR CASE 100 DIRECT DRIVE)

***** SPONSORED BY *****

 TEAM ASSOCIATED

 TRINITY

 COMPETITION
PLUS THE R/C CAR MAGAZINE

 R/C PRODUCTS

 Hyperdrive
Power Systems

 ROBINSON
RACING

 TEAM
COBRA
THE RACERS CHOICE

 Team
ITRC

NORRCA OFFICIAL 1990 TRI-STATE CARPET OVAL CHALLENGE ENTRY FORM

NAME _____ PHONE _____

ADDRESS _____

CLASS(ES): GEAR CASE OPEN _____ GEAR CASE STOCK _____ DIRECT DRIVE OPEN _____
DIRECT DRIVE STOCK _____

FREQUENCIES 1. _____ 2. _____ 3. _____ SPONSOR(S) _____

ENTRY FEE: \$28.00 STOCK CLASS (INCLUDES 1 MOTOR) \$20.00 OPEN CLASS. NO REFUNDS
SEND ENTRY & CHECK PAYABLE TO FUNTIME R/C RACING, 508 RIVERSIDE ST.,
PORTLAND, MAINE, 207-878-3129. ADD \$5.00 FOR EACH CLASS FOR ENTRIES RECEIVED
AFTER JUNE 16TH, 1990.

NORRCA # _____

there was at the beginning of the A main; and there was no more thrill of the win at the end of the A than there was at the end of the F. Racing is racing, but it remains that the fastest cars and drivers were in the A and B mains.

Lee Robertson of Seattle led the Stock B main for the first three minutes when a broken spindle took him out of the action and Stewart Keene of Beaverton, Oregon took over the lead for a decisive victory with twenty-four laps in 7:56.39. Carlos Gonzales of Edmonds, Washington, who just missed qualifying for the modified A Main, won the B Main after maintaining the lead for the entire race. Carlos, who is better known for national level off-road racing, turned twenty-eight laps in 8:4.13.

Perhaps the most exciting race of the day was the Stock A Main. Randy Holst went out for the early lead with Darren Stucker, Jon Wadkins, and Don Landaker right behind him. Early on Jon and Don began mixing it up for the third spot, exchanging positions several times while the two leaders were cruising just seconds ahead. After a few minutes of this it became apparent that Don was dropping just slightly off the pace. Meanwhile, at about the four minute mark, Randy and Darren began mixing it up for the lead. Every eye in the place was watching with jaw-dropping awe as these two traded off the number one spot more times than could be counted; more often than not, several times a lap, Jon was right behind this squabble waiting for the leaders to make the mistake that never happened. Folks, this race was the race of the day. The only way to describe it was that it was the cleanest dog fight I ever saw. On the last lap Darren made the final pass for the win with twenty-six laps in 8:9.69.

The Modified A Main was not so spectacular, but it was a good race. Byron Bressel took the early

A LAP MANAGEMENT COMPUTER

You Can Count On!

INTRODUCING

The
LC - 1000

"It's the most convenient system we've used... calling the racing action was exciting... recording the results was simple."

Montgomery County
Model Autosports Club

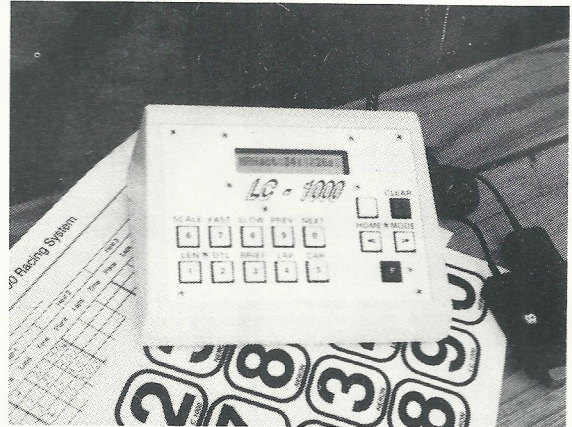

TOTALLY PORTABLE

The LC-1000 is portable and totally self contained. It can operate for an entire day of racing on a standard 7.2 volt pack. No need to break down and set up a cumbersome computer system. It's actually easier to carry than a 1/10th scale car.

REAL TIME REPORTING

Call the race, as it happens, from the display on the LC-1000. Time remaining, car position and lap counts, in lead car order, in both delta and absolute modes are instantly available. The LC-1000 can track up to 10 cars and retains the lap times for up to 1000 laps per car.

AUDIO/VISUAL PROMPTS

The LC-1000 gives an audible and on-screen countdown to ensure uniform starts and finishes. Periodic time warning tones and an on-screen clock keep officials, contestants and spectators informed.

INDISPUTABLE RACE RESULTS

The statistics provided by the LC-1000 enhance the fun and excitement of the race for fans and racers alike. Essential stats are displayed immediately after the race for quick announcing and recording of results.

Lap Count	Finish Position	Fastest Laps	Scale MPH
Total Time	Time for Each Lap	Slowest Laps	Actual MPH

The LC-1000 settles contested lap counts. It quickly locates fastest and slowest lap times to help you easily home in on questionable laps.

COMPLETE RACE MANAGEMENT

More than a lap counter, the LC-1000 is a complete race management system. Organize your races using the specially designed EZ-FORMAT racing forms and EZ-STICK racing numbers provided with the system. Optional, hand held, remote push buttons are available.

NERON ASSOCIATES
PO BOX 348-CP5
GERMANTOWN, MD 20875
(301) 972-0397

Only \$695

Plus \$5 shipping
and handling
Maryland Residents
add 5% sales tax

lead with Steve Curry, Chris White of Edmonds, and Bob Stormer close behind. Bob was able to overtake Chris in the last laps for third, but it was Byron Bressel for the win with thirty laps in 8:12.36, and Steve Curry in second. Bob Stormer was third, Chris White was fourth, Ernie Beasley of Portland was fifth, and Ron Steen of Mount-

lake Terrace, Washington (Dave and Georgia's son) was sixth. Jeff Travelstead and Kevin Tupper of Troutdale, Oregon both dropped out in the early laps with equipment problems.

This was racing in Edmonds, Washington early in March, 1990. It was a great weekend of fun and excitement for all thanks to the efforts of SARCAR and



RYDIN R/C RACING NUMBER SETS

YOUR NAME PRINTED ON EACH NUMBER

3¢ PER NUMBER

1,000 DIE CUT 1 THRU 8 NUMBER SHEETS FOR \$240.00
(ACTUAL SIZE SHOWN ABOVE)

SATISFACTION GUARANTEED OR YOUR MONEY BACK.

2 WEEK DELIVERY • ALL ORDERS SHIPPED UPS — C.O.D.

CALL 1-800-448-1991 FOR A FREE SAMPLE

RYDIN SIGN & DECAL
660 POND DRIVE
WOOD DALE, IL 60191



FOR FASTER SERVICE, CALL!
312-766-8410
1-800-448-1991

MAILING ADDRESS

Company: _____
Street Address: _____
City: _____
State & Zip: _____
Phone: () Night Phone: ()
Contact Name: _____
Today's Date: _____

SHIPPING ADDRESS

Company: _____
Street Address: _____
(We cannot ship to a P.O. Box)
City: _____
State & Zip: _____
Attention: _____
Date Needed: _____

Quantity	Your Track Name	Total
<input type="checkbox"/> CHECK ENCLOSED RECEIVE FREE SHIPPING		Handling Charge per order TOTAL
<input type="checkbox"/> SEND FREE SAMPLE		\$6.50

their officers Terry Varner, Sherman Joseph, and Eric Bourlet. Also thanks to Dave and Georgia of Raceway Hobbies in Edmonds for their facility and efforts. And a special thanks to Georgia again and Chris Lamb for accomplishing the impossible tasks of counting laps and weighing cars without a hitch.

**Modified
A Main**

- 1st - Byron Bressel
- 2nd - Steve Curry
- 3rd - Bob Stormer
- 4th - Chris White
- 5th - Ernie Beasley
- 6th - Ron Steen
- 7th - Jeff Travelstead
- 8th - Kevin Tupper

**Stock
A Main**

- 1st - Darren Stucker
- 2nd - Randy Holst
- 3rd - Jon Wadkins
- 4th - Don Landaker
- 5th - Terry Rutz
- 6th - Chris Brown
- 7th - Tim Roberts
- 8th - Roger Moore



**3RD ANNUAL WINTER
MIDWEST 1/10 OFF-ROAD
CHAMPIONSHIPS**

The idea was born in 1987. In January most midwestern racers have retired the dirt cars and are staying comfortably warm racing their 12th scalers on numerous carpet tracks popular in this part of the country. CORCAR (Central Ohio Radio Controlled Auto Racers) also knew that the fastest growing area of RC cars was 10th scale off-road. Shortly after the new year most racers are tiring of the cold and beginning to dust off the dirt cars and adding those Christmas additions in anticipation of warmer times.

CORCAR begun the late winter off-road race in 1987 and the idea has caught fire. The event held January 13th and 14th at the spacious Cooper Arena on the Ohio State Fairgrounds had to be limited to 320 entries this year. Thanks to the exposure the flier got at the 12th scale Indoor Championships in Cleveland and in issues of Competition Plus the race filled up before the Dec. 31st deadline.

Racers from thirteen states

ARISTOTLE THROTTLE

PRESENTS

THE

PHILO

ELECTRONIC SPEED CONTROL

ARISTOTLE THROTTLE has been repairing, upgrading and tuning electronic speed controls for competition in the Pacific Northwest for two years; and has now combined that experience to make what may be the **HOTTEST NEW SPEED CONTROL** on the market today!

SPECIFICATIONS:

- Current Capability: 360 Amps
- Voltage Drop: .002 Volts/Amp
- Weight: 1.6 ounces
- Size: As small as possible
- Throttle Linearity: Nearly Perfect

THREE MODELS AVAILABLE:

1. **PHILO IHS** - Low Torque
2. **PHILO IHN** - High Torque
3. **PHILO FHG** - Marine

All Three Share the
Same Specifications

These speed controls are designed specifically for racing applications only and are available now direct from **ARISTOTLE THROTTLE**. Each unit is numbered and registered in the purchaser's name.

TO ORDER YOUR PHILO:

CALL ARISTOTLE THROTTLE AT **206-776-8968**

OR MAIL TO:

ARISTOTLE THROTTLE
9792 Edmonds Way, Suite 166
Edmonds, Washington 98020

Include your check or money order for \$99.95 + \$6.00 for shipping and handling for the low and high torque models, or \$149.95 + \$6.00 for the marine model.

For a limited time **ARTISTOTLE THROTTLE** will allow a \$10.00 trade-in allowance for your Tekin or Novak Esc, working or not.

P.S. Aristotle Throttle Also repairs, upgrades, and tunes Tekin and Novak ESCs.

Repairs: \$20.00 + Parts, Shipping and Handling
Upgrades: \$45.50 and Up + Shipping and Handling
(Includes STAGE III wire)

And for you Monster Truckers and Tractor Pullers, we have a mod that will give you tons of power in both forward and reverse with twin modified motors. Call us with your special application.

TEAM LOSI



1989

ROAR
AND NORRCA

Winners in 5 classes
at the 1989 Nationals
all agree...

"Luck had nothing
to do with it!..."



**1989 NORRCA BEST
OFF ROAD TEAM —**

- TQ-1st Two Wheel Stock
- TQ-1st Two Wheel Modified
- TQ-1st Stock Monster Truck
- TQ-1st Modified Monster Truck

BUT HERE'S WHAT DID!

- **JR-X2**
- **REVOLUTION**
RACING MOTORS
- **"NATURALS"**
NATURAL RUBBER RACING TIRES
- **PRIMETIME**
RACING BATTERIES



12 **TEAM LOSI PERFORMANCE
RACING MOTORS**

When performance counts... Team Losi offers *12 stock and Modified Racing Motors. On-Road, Off Road and Monster Truck, Revolution motors will perform for you!



SUPER STOCK
6060
27 Single

INSANE
6056
15 Double

JR'S CHOICE
6103
17 Double

MTM
6104
19 Double

DAYTONA
6105
13 Triple

...and Fast Hard Driving

National Champions

NEW!
JR-X2
 RACING MONSTER TRUCK
COMING SOON!

1989
Radio Control
CAR ACTION
Best 2 Wheel Car

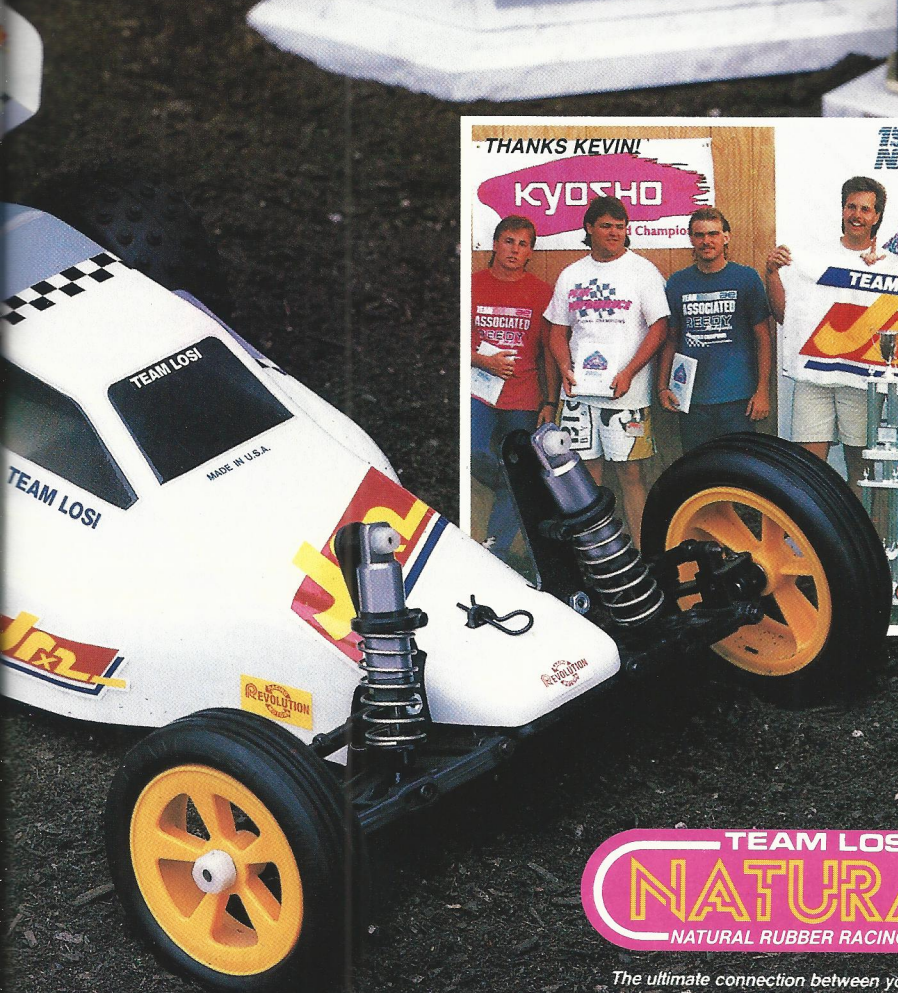

TQ- 1st Jack Johnson — JR-X2, Revolution "Motown Missile"
 2nd Kyle Reed — JR-X2, Revolution "JR's Choice"
 3rd Mike Dunn — JR-X2, Race Prep Powered

TEAM LOSI NATURALS NATURAL RUBBER RACING TIRES

The ultimate connection between your car and the racing surface. "NATURALS" are individually developed and constructed to deliver maximum traction and handling for all conditions.

MONSTER TRUCK TIRES

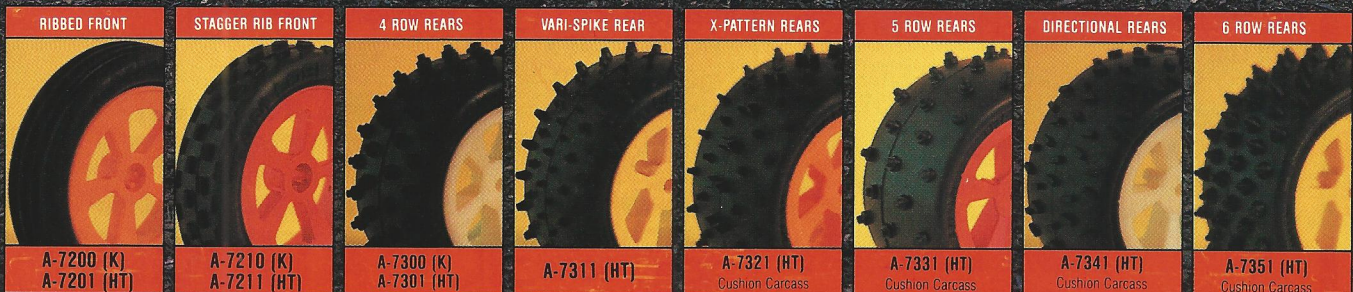
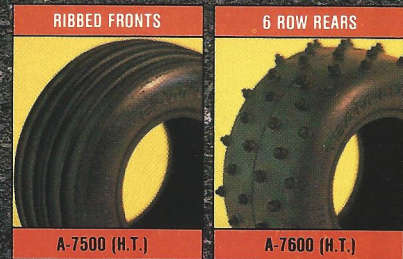

(K) — Kit, Long Wear Compound
 (HT) — Soft (Silver Dot) High Traction

TEAM LOSI PERFORMANCE

1655 E. MISSION BLVD., POMONA, CALIFORNIA 91766 (714) 620-0164

checked in Friday evening to receive their handout motors and begin practicing. Two of the local TV News Channels gave the race excellent coverage. The exposure drew hundreds of spectators to the fairgrounds that weekend and CORCAR expects the race will continue to add new racers to the sport. The continued success of the event has also brought in many established racing teams from all over the country, as well as the top Region 3 drivers.

The track for 1990 was similar to 1989 with the addition of a table top jump. The track began with a long straight-away into a wide sweeper that gave way to a double hairpin with a ridge running down the middle. From there the track alternates left and right turns with a variety of surfaces on each. The entire track was easily visible from the elevated driver's stand. What the drivers saw was a very 3-dimensional track that would test their suspensions to the fullest. The principle for the race seemed to be to keep the wheels on the



The Ohio State Fairgrounds offers the most spacious indoor off-road track in the nation.

ground and you might win. Before the weekend was over many racers with improper setups would find their cars wrong side up near a jump.

The Stock competition was run on Saturday. After the first

qualifying round it was thought that 10 laps might be good enough for the A Main. Only defending 2WD Champion, Mike Ankney broke that and he smashed it with an 11 lap 4:06

(Continued on Page 59)

All Orders
Shipped
Same Day

WAGONHILL HOBBIES



(412) 458-4711

225 S. Broad St., Grove City, PA 16127

>Over \$50 Shipped
Free in U.S.
>Mastercard / Visa
Discover
>C.O.D. Available

*Just Getting
Started?*

Let us help sort out
your questions about
this exciting sport.
Call Us!

Sale Prices On:

- >RC10 Kits - World Champ!
- >MRC Tamiya Kits - Easy Assembly
- >Truck Kits - Most Popular for new RC'ers

OR

*Heavy Into
Competition?*

ASSOCIATED
ADVANCED
ANDYS, BUDS
COMPOSITE
CRP, DANS
DIALED R.P.
HOUGE, IMEX
LIGHTSPEED
MRC TAMIYA
PROG. TEC.
RACE PREP
SHINWA, TEKIN
VICTOR, NOVAK
ZETA & MORE

We've got the parts to let you go
faster. Batteries, Chargers, Motors,
Electronics, More.

New:

- >Tekin 210 - Reflex Charger
- >Prog. Tec-Supergold Batteries
- >Power Supplies - Pyramid

FAST FRIENDLY SERVICE WHEN YOU WANT IT (412) 458-4711

REVOLUTIONARY BREAKTHROUGH DON'T GET LEFT BEHIND

AVERAGE TEST RESULTS:
12% MORE RPMS
 •
20% MORE TORQUE
 •
11% LESS AMP DRAW

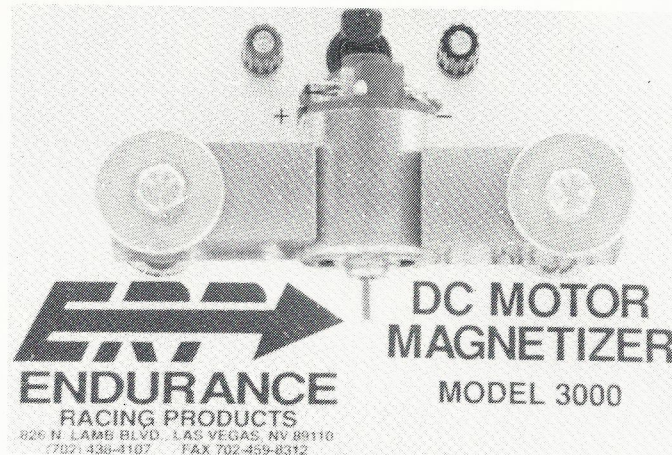

ONLY
\$249⁹⁵

PLUS \$10⁰⁰ Shipping & Handling
 9 LBS SHIPPING WEIGHT

FEATURES:

- EASY TO OPERATE
- SAFE TO USE
- ALL ALUMINUM CABINET (9"x5"x5")
- WORKS ON NEW OR USED MOTORS, STOCK OR MODIFIED

This incredible machine "RE-ZAPS" your motor to increase its overall power output significantly. This safe to operate device ends the need to buy another motor simply because the magnets have lost their power. Easy to use just hookup your 12 volt battery charger (10 AMP), insert your new or used motor, flip the switch and in approximately 20 minutes your motor will scream with new power! Horsepower output is measured by TORQUE x RPMS. This device significantly increases both torque and RPMS while usually reducing amp draw resulting in a more efficient, cooler running motor.

HERE ARE SOME OF THE COMMENTS WE'VE RECEIVED:

"The D.C. Motor Magnetizer is a MUST TO HAVE ITEM for the racer who wants winning motor power."

"You took a throw away motor and made it the best motor I have."

"You took a stock motor and made it faster than any of my modifieds."

"Best accessory for racers I've seen yet."

"Unreal low-end power and the speed is killer."

"Last year I spent \$1100⁰⁰ on motors and now I don't have to buy a new one again if I don't want to, but better than that, I've never had this fast of a motor before!

This is a whole new world for the RC Racer."

"I'm a believer."

PATENT PENDING – DEALER & DISTRIBUTOR INQUIRIES INVITED

**DON'T GET LEFT BEHIND ORDER NOW.
 MAIL TODAY OR CALL (702) 438-4107**



ENDURANCE
RACING PRODUCTS

"We make 'ya last longer"

826 N. Lamb, Las Vegas, NV 89110
 702-438-4107 FAX 702-459-8312

SHIP TO:

NAME _____

ADDRESS _____ # _____

CITY _____

STATE _____

ZIP _____

PAYMENT U.S. FUNDS ONLY.

AMEX MC VISA CHECK/MONEY ORDER

CREDIT CARD # _____

SIGNATURE _____

EXP. DATE _____

X _____

NEVADA RESIDENTS ADD 6% SALES TAX.
 SORRY NO C.O.D.'s. ALL ORDERS SHIPPED U.P.S.

PARMA'S

Pro Panther 12

By Jeff Palmer

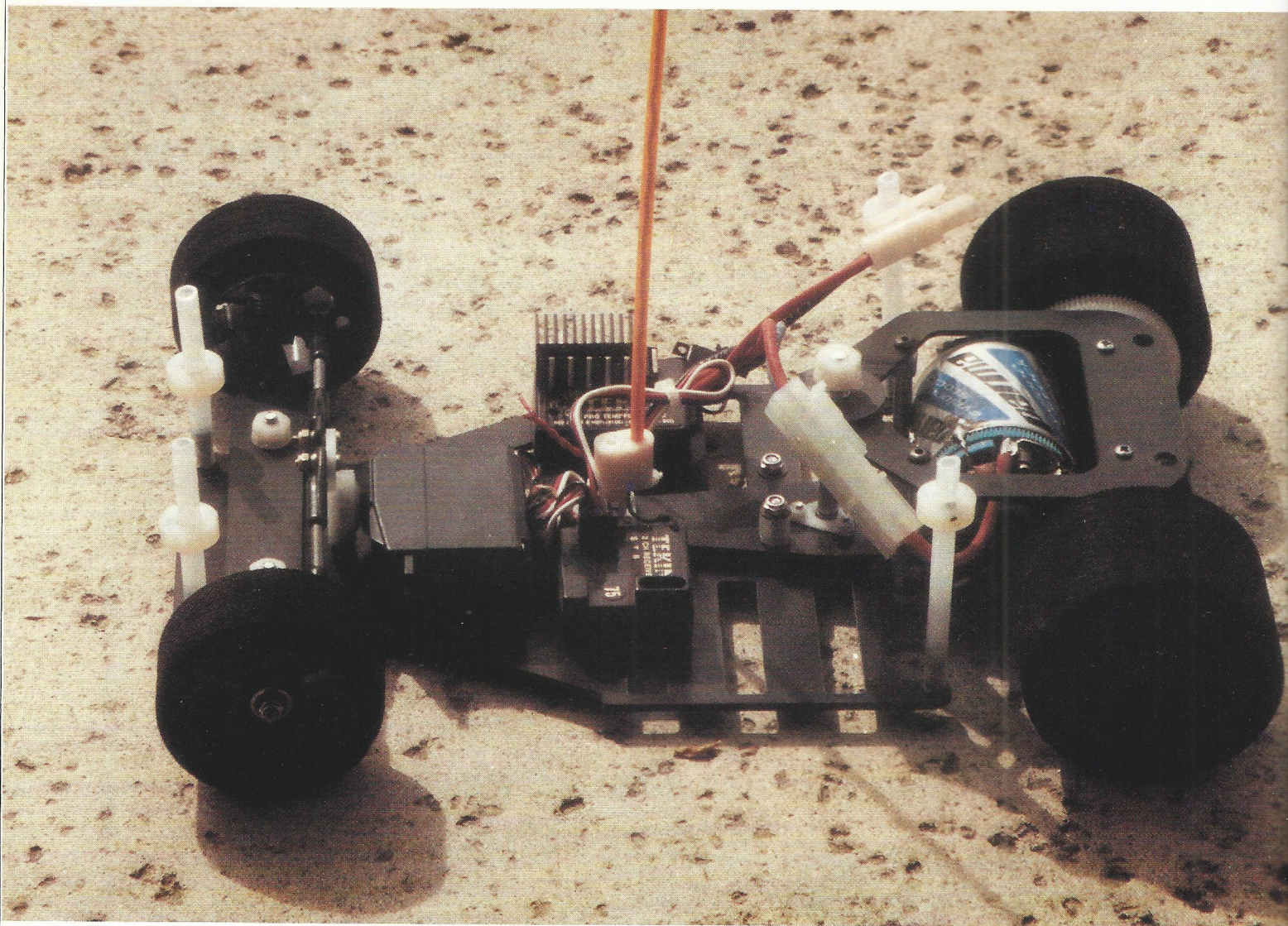

Today's 12th scale racing is one of the most competitive categories in R/C racing with the Associated 12L, TRC 12 and Corally SP II all jockeying for the

top position.

The sophistication of today's cars are evaluated on dampening the motion of the rear power pod, the overall weight/power ratio of

the car, and the efficiency of the transfer of power to the ground. Parma's Pro Panther 12 is a car that is designed to compete in this category. The graphite ver-

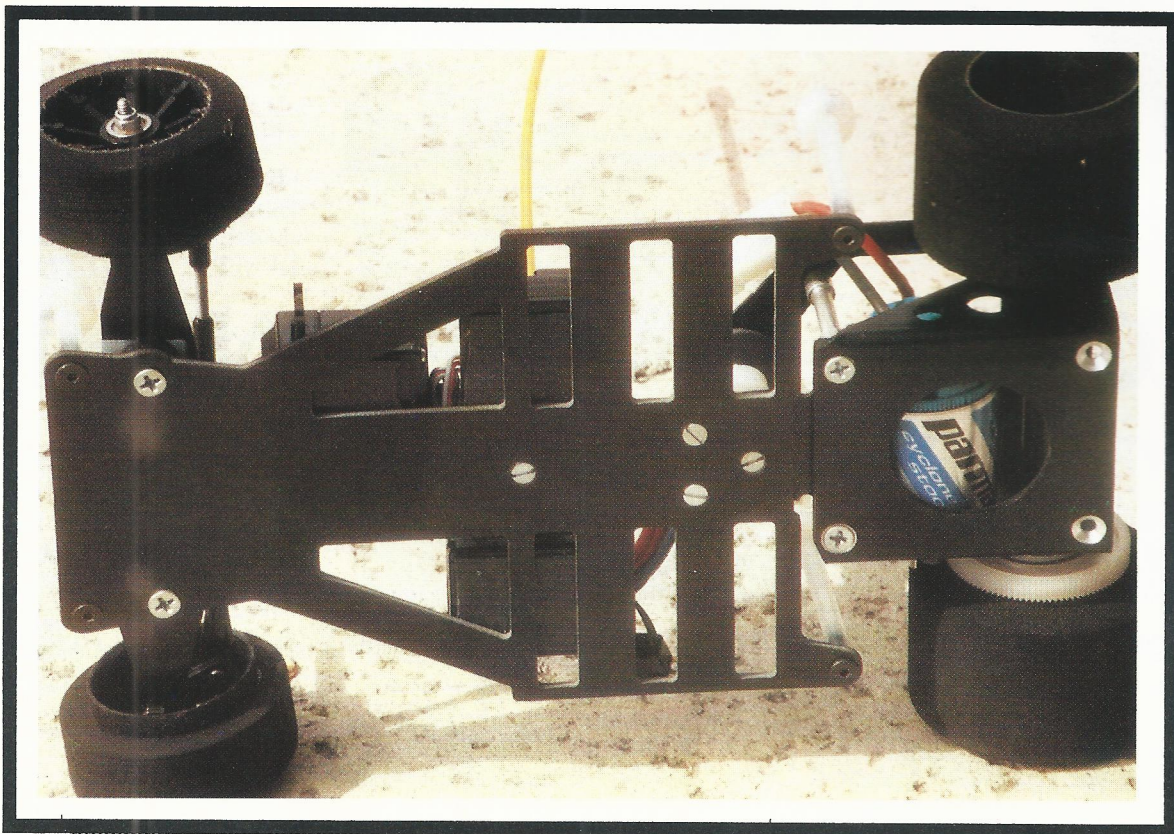

The above photo shows the Parma Pro Panther 12 chassis with the T-plate rear suspension and rear pod assembly.

sion of the Pro Panther 12 is Parma's entry into the 12th scale arena. It features ball bearings, graphite axle, simplified power pod and the Parma version of the Pro Diff. It has a cross-arm front end with spring dampened steering blocks, T-plate rear suspension and power pod assembly that is spring dampened. It's a car kit with very few parts and is simple in design.

CONSTRUCTION

The first page of the instructions describe tools that will be required to assemble this kit. Some extra materials required to assemble this kit are, a tube of Loctite "Threadlock 242" to secure many of the screws in place and Paragon "Ultralon" to lubricate moving parts like bearings because it dries to a powder and helps prevent any

dirt build up. However, if "Ultralon" is used on the bearings, it needs to be thinned 50/50 with Lacquer Thinner. Enough - let's check out the instructions.

The six pages of instructions, of which only 4 are text, reflect the simplicity of assembly of the car. They contain a number of detailed photos of each assembly step accented by short paragraphs of written detail. At first glance, these instructions look to be informative and complete, but the beginner may need some help building this kit from them.

The first assembly is the "Front End." The front end consists of a pair of steering blocks on king pins with springs as dampeners mounted on a crossbar; standard 12th scale stuff. What's unique about Parma's approach is, they use "caster wedges". Caster wedges are the rectangular pieces of plastic tapered at 1, 2,

and 3 degree angles. They are used to tilt the front crossbar at the proper angle to improve steering. The caster wedges are mounted on top of the nylon spacer, which separates the front end crossbar from the chassis. Start with the 2 degree and experiment to find the right caster for your driving style. The part that makes this difficult is the poorly reproduced photos, they're too light or washed out. Secondly, the first photo, a parts explosion of the crossbar assembly, is upside down in relationship to the other two photos used in this section. One other note for beginners, the term "stand-offs" means "spacers."

The next assembly is the "Rear Pod." Again, the first photo of the assembly is a complete parts layout of the assembly. That's great, but the reproduced photo in the instructions is very light

Hobby World

presents the

2nd Annual

1/10 - 1/12

HOOSIER CHAMPIONSHIPS

Indoor On-Road Oval

- Summers First Blow Out!
- We're Looking for All the Top Drivers from: Indianapolis, Nashville, Paducah, Louisville, Terre Haute, Anywhere They Go fast & Turn Left!
- Congratulations to Last Years 1/10 On Road Stock & Mod Winner, *DAVE PULFER*

Classes: 1/10 On Road Stock & Mod, Nascar Bodies - Stock, Nascar or ASA - Mod
1/12 On Road Stock & Mod, Nascar Bodies - Stock, Nascar or ASA Mod
2 WD Gear Case Stock & Mod, Any Body

AMB Lap Counting
Excellent Pit Area w/Elec.
Fully Stocked Hobby Shop

Top 3 Each Main - Trophy
TQ Trophies
5 Min. Heats
3 Rounds of Qualifications

Friday, June 1

Open Practice
Track & Hobby Shop
Open to Midnight

Saturday, June 2

STOCK Qualifiers
& Mains

Sunday, June 3

Mod. Qualifies
& Mains

Pre Entry

Entry Closes May 29

Class Entered: Stock _____ Modified _____

Name _____ Address _____

City _____ State _____ Zip _____

Phone _____ Frequencies #1 _____ #2 _____ #3 _____

Entry Fee: Modified \$20.00, Stock \$30.00 (Includes motor)
Mail or bring entry to **Hobby World**, 1508 N. Harlan Ave., Evansville, IN 47711

For more information call **812-421-1100**

Maps, rules, & info will be sent by return.
All entries non-returnable. Come see Racing at it's best!!!

and a lot of detail goes unnoticed. Follow these instructions to the letter and pay close attention to the position of the rocker balls. In the second photo for this section, the longer portion of the rocker ball goes on top. Special attention needs to be given to the last paragraph of the section where it talks about the rocker ball assembly. **IT'S CRITICAL TO THE HANDLING!!**

The third assembly is the "Chassis Assembly". Here the rear pod assembly is attached to the chassis and the T-plate damper is assembled. During the construction of the T-plate damper, I used a thick silicone diff lube to increase the dampening action. This slows down the spring action providing a slower but smoother action; more like a shock absorber.

The one paragraph in the Chassis Assembly that caused a lot of grief to me was "Next, assemble differential per instructions enclosed in bag." The instructions in the bag were the "Parma Associated Differential

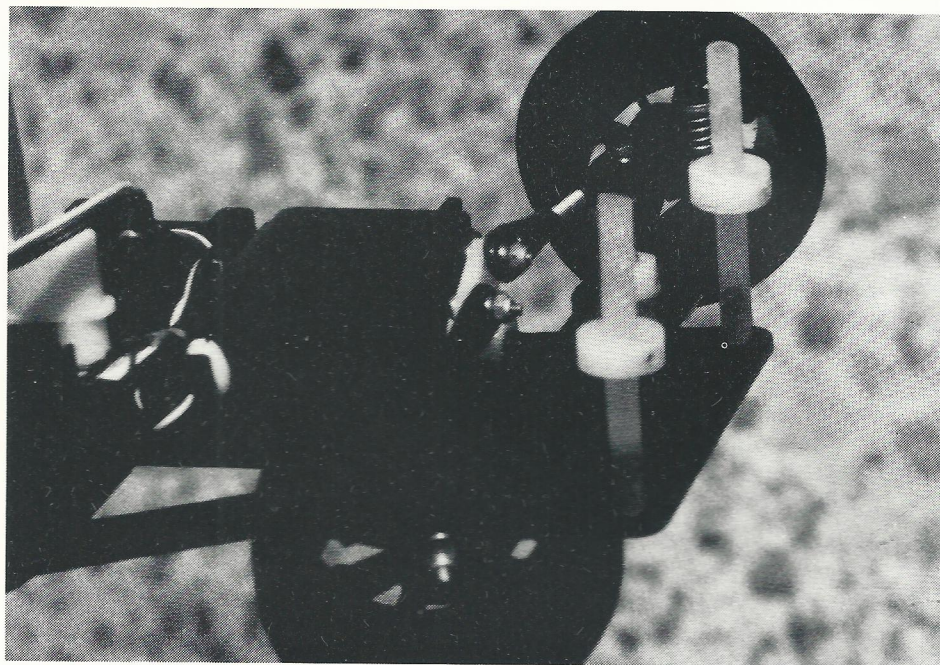

Note the cross-arm front end with spring suspension dampening steering blocks.

Instructions" which is not the diff in my kit. The graphite version of the Pro Panther 12 comes with the light weight spoke wheels which require a different diff setup; it's more of the Bolink style of the "pro diff". The ironic part is, the photo provided in the

instruction manual, is the one that has the correct parts explosion for this diff assembly. I used this photo to assemble the diff.

The "Final Assembly" is just that, put the wheels on and add the motor and electronics and

It's as simple as 1 - 2 - 3!

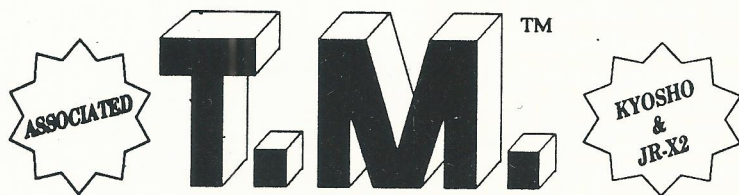

**R/C RACING COMPONENTS
NEW
VALVE-A-MATIC'S!!®**

Eliminate problems with your off road car bouncing off bumps or when landing off jumps. Smooth out those hard to handle rough tracks, and make your car or truck handle like the real off roaders!

With VALVE-A-MATIC'S, your shocks will work like shocks were meant to work! All you need to do is replace your stock pistons with the new VALVE-A-MATIC (2) piece pistons. VALVE-A-MATIC'S will work on front and rear shocks (Short, Medium, or Long) stroke, and are available for Associated, Kyosho and JR - X2 shocks.

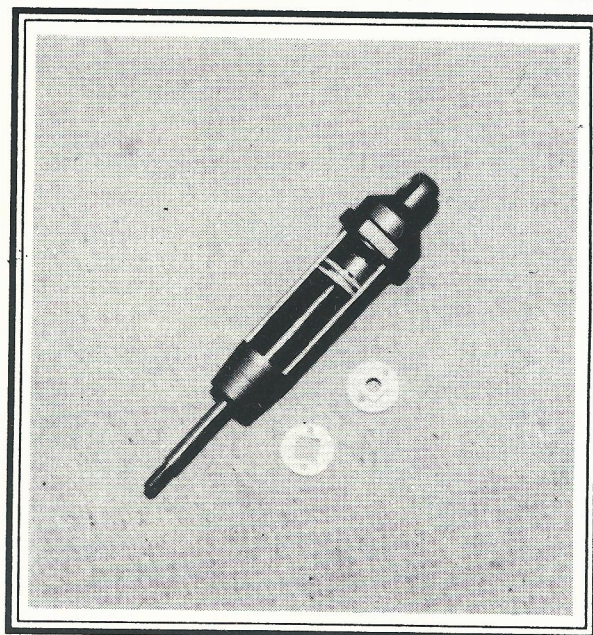

T.M. R/C RACING COMPONENTS • 49679 LEONA • MT. CLEMENS, MI 48044 • (313) 949-3506 • FAX: (313) 949-3506

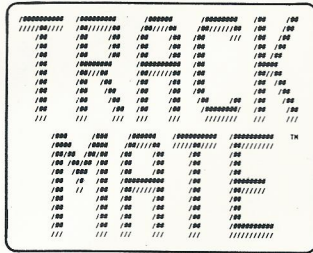

- Handcount and AMB Systems
- Frequency clear qualifiers
- Unlimited number of qualifiers
- Class Standings each round
- Sorts Mains between heats
- Immediate Point Standings
- Driver Ranking Feature
- Customized to your track

If you need a race management program, **TrackMate** can help. We are the experts in user friendly race management. This is **TrackMate's** fourth year and its glitch free operation guarantees you a successful race every time out. There is no other race management program available with the features offered by **TrackMate**.

TrackMate comes in three sizes to fit your track and budget. **TrackMate Jr.** is perfect for small, hand-count only tracks like Master Raceway while **TrackMate Pro** handles the regional and national event tracks like Lake Whippoorwill. Standard **TrackMate** is just right for all those mid-range tracks that either hand-count or use the AMB System. All three versions offer automatic race series points management for your drivers.

Call for our FREE Demo Disk

TrackMate Systems 508-435-6008

TrackMate is a trademark of TrackMate Systems

let's get to racing. As usual, I used turn buckles for the front end steering tie rods to simplify alignment. Next, I found the smallest receiver and speed controller available, Tekin's Micro PRO Receiver and ESC-300PT. Parma's Stock Cylcone motor was used and now we're ready for the track. I crowned this chassis with one of Parma's own custom painted bodies, Osella PA9.

ROAD TESTING

As with all new cars, adjusting the diff was the first priority. The Parma Pro Diff has a very smooth action but I experienced some wheel hop problem. The problem was related to the right rear wheel. I solved the problem by adding a bearing to the outside of the wheel and changing the thrush washers to a thinner one solved the problem. While I had the diff apart, I changed the 32 pitch kit gears for 64 pitch gears, it offers finer tuning between torque and RPM.

Next, I added a Bud's "TOJ" stabilizer wing and now I was ready for the final setup and a trip to the track. To do the next two adjustments, the car must be completed, that is, the ESC, radio, batteries, and motor must all be installed. To the tweak, Parma recommended running the rear pod loose so it shifts easily. Translated "loose" means the silicone rubber tubes should only be slightly compressed. To adjust the tweak, tighten or loosen the nuts that hold down the silicone rubber tubes on the rear pod. Adjust the tweak until it's perfect, the instructions tell how to use the "knife method" of tweaking. To complete the setup, adjust the spring tensions of the rear T-plate so the chassis is parallel with the ground. The T-plate effects the steering by controlling the amount of push. The stiffer the T-plate, the less the car pushes when cornering and the more it tends to oversteer.

Caster is one of the setup options in the instructions. They

call for 2 degree caster on the front crossbar. Since caster is relative to the responsiveness of the car, work with it until it's right. Too little caster and the steering will snap the car through the corners; too much caster and the steering is sluggish in the corners. I settled for 3 degrees.

I took the car to the local carpet track, Eagle Hobbies in Dallas, Texas, and put the Pro 12 to the test. At the track, the Panther was stable and held good lines in the straight away and it had minimal push in the corners. With the car setup it was time to "wind it out" and see how it would perform. I added Paragon's "Ground Effect" to the tires for time laps for that little extra traction. The car accelerated well through straight aways, but in tight corners, it wanted to swap ends. Overall, the car handled well, but I felt the performance of the rear pod could be improved to provide increased traction. To accomplish this improvement, I disassembled the T-plate and polished the dampener post with a little rubbing compound. Then I re-assembled the T-plate, making sure the dampener washers move smoothly up and down the post. Then I placed Bud's #7460 Silicone Lube on the inside surfaces of the dampener washers. The polishing improves the T-plate up/down motion and the thick lube slows the action. This modification allows the PRO 12 to be competitive with the big boys - Associated 12L and the TRC 12.

CONCLUSION

Parma has a great entry to intermediate level racer in the Pro Panther 12. The only problem with this kit is the instructions and Parma is taking steps to correct this problem in the future. The car handles well and is fun to drive. Thanks Parma for your willingness to make minor changes and your continued delivery of quality products. "Til next time, GOOD RACING!!

Bud's Racing Products
 P.O. Box 601
 Amherst, Ohio 44001-0601
 (216) 965-5247

Paragon Racing Products
 690 Industrial Circle South
 Shakopee, MN 55379
 (612) 496-0091

Parma International
 13927-M Progress Pkwy.
 North Royalton, OH 44133

Tekin Electronics
 1027 Trepadora
 San Clemente, CA 92672
 (714) 498-9518

■CP

NEW!

Computerized Lap Counting

NOW: Version RCC5.V4 will run your races from sign-up to trophy awards! Using compatible PCs or TRS-80s.

From simple sign-up sheets and quick data entry, the CDS program will make up the entire qualifiers and mains racing schedules, resolve frequency and car number conflicts, print racing schedules and save all data to disc.

Race director has options to select number of cars per race for all classes, and sequence of racing class events.

The actual racing program can run automatically by sequence or be selected by event number from the event schedule. The mains will be automatically made up from quickest qualifying times and laps. All the extensive features of existing RCC5.V3 program have been retained and enhanced to run quicker and easier. Watch for the greatest Total Automatic System Announcement. We at CDS have done it! The fully automatic system, RCC5.V5, will be provided as an integrated system including software, lap counting devices, computing, displaying and printing equipment. A complete across-the-counter line of components will be available for retail sales.

We are tooling up to have RCC5.V5 on the market very soon.

Suggest you purchase the RCC5.V4 system now so that you will be computer-wise when the remaining hardware will be available.

Coordinated Data Service Co.

(619) 788-6851

CAR KIT SPECIFICATIONS

KIT:
 Manufacturer Parma
 Model Pro Panther 12
 Type On-Road
 Scale 1/12

CHASSIS & BODY:
 Chassis Type Pan
 Material Aluminum/graphite
 Body not included
 Material N/A

ELECTRICS:
 Motor not included
 Receiver not included
 Speed Controller not included

WHEELS:
 Front Parma
 Rear Parma

GENERAL:
 Weight(compl./6 cell) 31.26 ozs.
 Wheelbase 7.38 in.
 Track (front/rear) 5.8/4.87 in.
 Length 14 in.
 Width 6.65 in.
 Height 3.25 in.
 Bearings/bushings bearings

SUSPENSION:
 Front Springs
 Rear T-bar dampener

DRIVE TRAIN:
 Type Direct drive/ball
 Ratio 5.4:1
 Gears (pinion/spur) 20/108

TIRES:
 Front Parma Panther
 Rear Parma Panther

OPTIONS
WHEELS:
 Front Stock
 Rear Stock

ELECTRICS:
 Motor Parma Cyclone Stock
 Receiver Tekin TER
 Speed Controller Tekin 300PT
 Batteries Parma SCE

TIRES:
 Front Stock
 Rear Stock

CHASSIS & BODY:
 Chassis Stock
 Material Stock
 Body Parma Osella PA9
 Material Lexan

COMMENTS:
 Chose Tekin receiver and ESC for its small size and light weight.

ROAD TEST:
HANDLING:
 Acceleration Excellent
 Cornering Good
 Rating Very Good

COMMENTS:
 This car needs some work on the T-plate suspension.

Pro Auto Peak - \$34.95

A Revolutionary Concept in Charging Technology

- Peak Detection Converter
- Instantly Converts ANY DC. Fast Charger (even charge cords) to a Peak Detection Charger
- Provides Increased Power & Run Time
- 100% Safe and Automatic
- Compact Size 3x2x1 1/4"



Both Units Feature:

- Use with Cars, Boats, Planes
- Tamiya Connectors
- One Button Operation
- LED Indicator
- Electronic Detection Circuitry
- Built In Self Test Routine • Automatic Switch to Trickle Charge

Pro Power Peak - \$49.95

- Self Contained DC. Peak Detection Charger for 6 or 7 Cells
- Transistor Current Regulator
- Pulsating LED Charge Indicator

Available thru local dealers or from The Pro Shop, P.O. Box 5382, Parsippany, N.J. 07054
 Include \$2.00 P&H-N.J. residents add 6% sales tax-check or money order only-no C.O.D.

Distributor Inquiries Invited

Kyosho Puts 1/8 Scale Gas on the Fast Track by Bill Jeric

Kyosho is launching a full scale campaign to bring 1/8 scale gas off-road racing to the attention and enjoyment of American R/C racers with a new series of sponsored races. The "Kyosho 1/8 Scale Off-Road Challenge" race series will work to bring you the best in experienced gas racers plus new entries from the ranks of electric racers.

America Follows Trends in Europe and Asia

In Europe and Asia, 1/8 scale off-road gas racing is hot. The size of 1/8 scale both in terms of the machine and the track allows for greater realism and increased excitement. There is a heft to the machine that means serious business. Seven and one-half pounds of highly engineered components are propelled down the straights at speeds from 40 to 50 actual mph.

What R/C enthusiasts in Europe and Asia have found out is that driving 1/8 scale gas cars brings them closer to the real thing. The sound of the engines, the horsepower, the speed, the appearance and even the smell of nitro creates a rush of excitement that Americans can relate to and race to.

For drivers of 1/8 scale gas who come from the 1/10 scale electric ranks it's a chance to test their mechanical and driving skills with a machine that's faster, heavier and moves like a pit bull on a mission.

New Event for Track Owners

The Kyosho 1/8 Scale Off-Road Challenge race series will be taking place all across the country. At chosen tracks, these sponsored race events will be given extensive publicity.

From these track locations, Kyosho expects the speed, the excitement, and the absolute fun of 1/8 scale gas to spread to selected R/C tracks all over America.

With 1/8 scale gas off-road a track owner is offered a new form of racing. One that turns up the volume and with speeds that can be best described as "ballistic." Spectators love the action and 1/8 scale runs a shiver up the back of R/C car hobbyists looking for a greater thrill.

Almost any good sized off-road track will accommodate 1/8 scale cars. Ideally, the

straights should be at least 100 ft. long and the lanes should be 6 to 8 ft. wide. Smaller tracks can simply run fewer cars per heat. An advantage of 1/8 off-road is that minimal track maintenance is necessary. These cars can tackle virtually any type of surface, no matter how rough.

Racers and spectators get more than just a few brief moments of action with 1/8 scale. In gas off-road, qualifiers are usually in the 5 to 10 minute range with mains lasting between 30 minutes and one hour. Pit stops for fuel are required during the main event.

A Proven Track Record

Kyosho is ideally suited to champion the 1/8 scale gas movement in America. As a leading manufacturer of electric R/C race cars and monster trucks, Kyosho has developed the technology that recognizes the demands of racing at 40 to 50 mph speeds on terrain that can be smooth, rough or anywhere in between.

Kyosho's Burns DX and Turbo Burns 1/8 scale off-road cars are classic examples of designs that match the demands of the racing category. The result is a combination of years of experience with R/C cars and advanced engineering. Unique suspension systems, .21 buggy engines and chassis configurations work together to allow maximum speed with optimum control.

The Kyosho Burns series is an out front 1/8 scale competitive choice and was raced to 2nd Place in the 1988 IFMAR World Championships.

Three Cars in One

All types of people are drawn to 1/8 scale gas cars. While 1/8 scale gas is ideal for dirt off-road racing, the opportunity for other forms of racing is clearly there. Some prefer dirt off-road courses while others lower the suspension, add an 1/8 scale ASA body and tear into some exciting dirt oval action. The addition of a set of slicks puts a 1/8 scale gas car on the asphalt for oval racing.

The versatility of 1/8 scale gives the owner an investment of three cars in one.

1/8 Scale Started It All

1/8 scale gas on-road racing is really the roots of R/C car racing as we know it today. In the 1970s, on-road gas was where it all began. Equipment was crude in those days and reliability was a major stumbling block to early 1/8 races. Electric racing came into being and is almost totally responsible for the explosion of interest in R/C cars of all scales, both gas and electric.

Today, with advances in technology of engines, radios and chassis, the 1/8 scale gas off-road category is a form of racing to be easily enjoyed by any R/C car enthusiast. Kyosho pledges to provide the push needed to raise the awareness of 1/8 scale racing and to rally the R/C racers who wish to share their interest in this high-speed racing class. The "Kyosho 1/8 Scale Off-Road Challenge" race series is only the beginning!

You Can Become Involved

Kyosho is serious about getting 1/8 off-road up to speed in America. If you, your club or track are interested in a ground floor opportunity to get involved in helping to promote this new, exciting category, call Bill Jeric or Tom Grogg at Kyosho (217) 398-3630 or write c/o Kyosho, P.O. Box 543, Champaign, IL 61824-0543.

Kyosho 1/8 Scale Off-Road Challenge Race Schedule 1990

Watch here in coming months for the latest race dates

"Let them eat dirt... it's the right thing to do."

Eating dirt in 1/8 scale gas off-road racing is nasty. But somebody's got to do it. When you command a **Kyosho Burns DX** or **Turbo Burns**, you have obviously decided it's going to be somebody else.

Burns DX: the affordable edge.

The Burns DX 4WD gas buggy puts you out front and keeps you there. Its heavy-duty steel drive shafts are driven through an adjustable center differential. The high-strength alloy aluminum chassis and heavy-duty suspension with oil-filled shocks take whatever punishment the terrain can dish out. Most people's extras are included as standard equipment: racing body, tuned pipe and header, and fuel tank.

You can do more with your Burns DX than race off-road. Add a 1/8 scale sedan body and you have one

mean 4WD dirt oval racer. How about on-road? All it takes is slick tires like DuraTrax makes and a body of your choice.

Turbo Burns: the best a 1/8 scale gas buggy can be.

Turbo Burns is serious, all-out off-road power, put together with absolutely the best parts and accessories available. A new heavy-duty suspension featuring longer arms improves running performance. Large volume shocks offer superb handling while complete ball bearings reduce friction for blistering speeds. Also included are a new aerodynamic body and wing.

For action that's bigger, better, and laced with the smell of nitro at a blistering 40 mph plus...command a Kyosho Burns DX or Turbo Burns.

And let them eat dirt.

Finished 2nd at 1988
IFMAR World
Championships.



**TURBO
BURNS™ 4WD**

KYOSHO
BURNS™ DX

DISTRIBUTED TO LEADING RETAILERS
NATIONWIDE EXCLUSIVELY THROUGH
 **GREAT PLANES™**
MODEL DISTRIBUTORS COMPANY
P.O. BOX 4021, CHAMPAIGN, IL 61824-4021

See the Kyosho Burns DX and Turbo Burns
at your hobby dealer.

TEAM LOSI'S

JRx2 PRO

PART II

By Dan Bullock

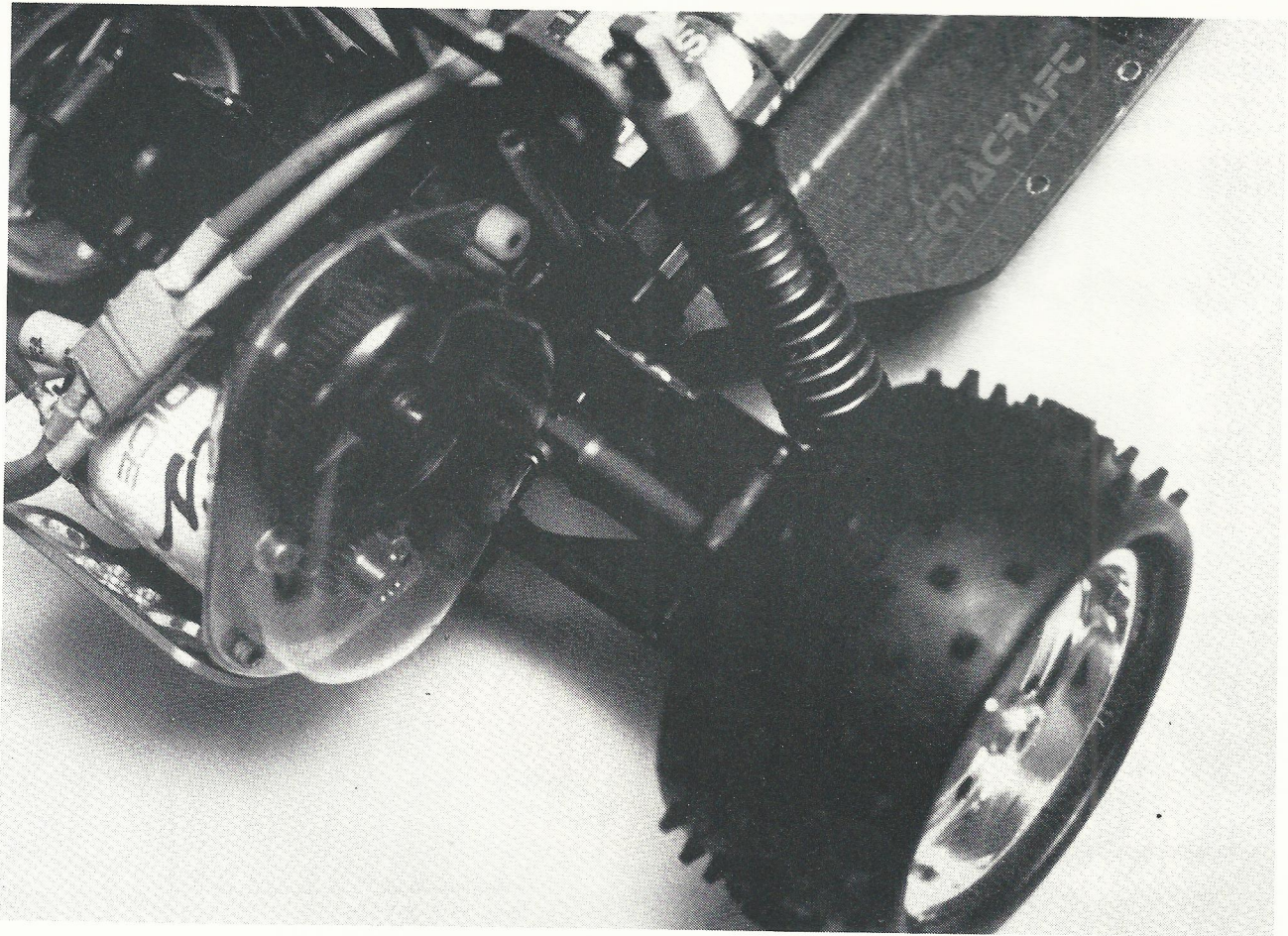

Note that the clear plastic motor cover is trimmed in the front edge to clear the upper control arm of the right rear suspension.

Stock antenna mounting position is maintained. The front Servo used is a Futaba 9601 with 33.3 oz-ins of torque. Care is taken to make sure that the titanium rod used to connect the servo saver to the steering sector arm ball end is adjusted to a 90 degree angle with the servo saver to give the equal right and left steering. After mounting the Tekin ESC600 speed controller at the mid point on the chassis, a

TERX micro receiver is placed on the opposite side of the battery cup, also at the mid point of the chassis. Wiring with Stage III 13 gauge fine strand wire is done to maintain the shortest possible connection distance to the motor. The rear shock tower can be used as an alternate speed control mounting point.

The "Junior's Choice" 17 double motor is wired and lightly broken in. Race Prep gold plated

connectors are used throughout. Care is taken to provide suitable capacitors to limit noise production and a 21 tooth pinion is fitted to the "Junior's Choice" motor for use with a 6 cell matched SCR pack. The clear plastic motor cover is trimmed in the front edge to clear the upper control arm of the right rear suspension.

Team Losi stagger rib high traction front tires and X-pattern

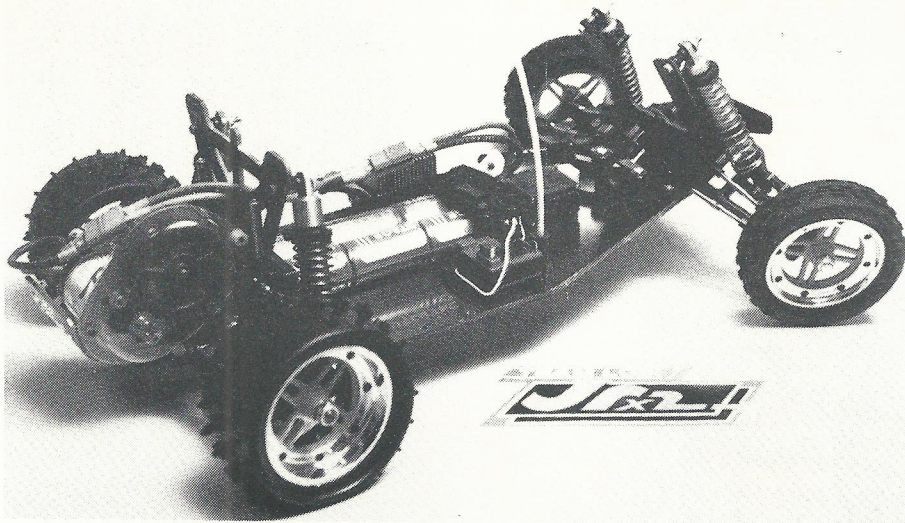

An overall view of the JRx2 Pro.

high traction cushion carcass, rear tires are fitted to your wheels of choice, in this case, Technacraft Polished Aluminum Modular Wheels and Team Losi A-6304, 10-32 aluminum lock nuts are used to secure the wheels to the axles. Superglue application to both front and rear tires will prevent them from stripping off the wheels or allowing wheel spin within the rear tires. For many applications high traction rib fronts will provide ample front steering.

A Team Losi Insane (15 double) or Mo-Town missile (12 single) may be used with SCE 6 or 7 cell packs to provide extra power where traction is excellent. Using the super suspension tuning guide, the ideal set-up for each track you race at can be determined. Remember to change only one thing at a time or you can get totally lost.

This set-up will give you approximately 2-3 degrees front negative camber and the same at the rear. Ride height should be adjusted by sliding the shock mounting clamps up and down on the shock body so that the front arms are parallel with the front bulkhead. If many jumps are present at your track, slightly higher nose ride height will keep the nose a little higher on jumps

but will give a little less steering.

In contrast to the Losi 5 link rear suspension, toe-in should be set so that the front tires are straight or with slight toe-out. Toe-out will give more low speed steering and may make the car "hook" more exiting corners.

CHASSIS TUNABILITY

That's the operative phrase for the JRx2 PRO. I have raced a JRx2 with the PRO set up for several months and have been extremely satisfied with the overall performance and especially the ease of fine tuning. A little more work is required for the JRx2 to tune it to each track but the level of performance is far superior to currently available cars.

Start with the track you're going to race on. Using the PRO long chassis and long front shocks and towers as the base set up, all jumping problems are gone. Get a high lighter and mark Jack's tips in this section and take them with you to the track. It is important to realize that the H-arms DON'T work every where. They're good for smoother, well groomed tracks with a consistent surface and good traction (regular watering). That's the way many national or regional tracks are designed,



**"Your Power Source
for
Batteries & Motors"**

**NEW
MOTOR TECHNOLOGY**

Terry Riley's Texas connection has developed a line of R/C motors to give you the competitive edge!

Texas Pride goes into the preparation of each motor. Each motor uses advanced R & D computer and custom-made dyno to insure each motor to highest quality & performance.

**TEXAS
CONNECTION**

P.O. BOX 1449 • 106 E. MAIN
VAN, TX 75790

Phone (214) 963-5729 Fax (214) 677-1503

Send FREE motor tips

Enclosed \$4.00
Send latest catalog.

Enclosed \$25.00
Send new motor
(new offer only)



NAME _____

CITY _____ STATE _____

ZIP _____ PHONE _____

they're FAST, usually with several high speed sweepers. H-arms!! At most local tracks, however, the surface is much LESS consistent and well groomed. It's often choppy, rough and slippery. THINK 5-LINK!!! Sometimes you'll start high speed, smooth and the track deteriorates and you'll need to change from H-arms to 5-link.

Why? H-arms by nature give less rear bite and make the car

Find Out How Good You REALLY Are!



Trinity® PUSHED™ Cells... The Winning Difference

The days of winning without PUSHED batteries are over. Guys like Joel "Magic" Johnson®, Tony Neisinger, Bob Light and Andy Dobson know that. Batteries are that important edge. That's why Trinity PUSHED cells are cycled through our computerized charging and conditioning sequence.

Trinity's special PUSHED conditioning increases the battery's capacity, voltage output and run-time. Our computer analyses each cell and prints the results right on the label.

You know you are good. The question is, "How good?" Eliminate all doubts. Use Trinity's hottest cells and find out.

0359	1.09	Run-time at discharge rate
5.00	20.0	Average volts during discharge
Trinity		Discharge rate (amps)
PUSHED		Peak charge rate (amps)
Cells		

Battery Label

SCR			
4-Cell	#5500	\$39.99	
6-Cell	#5501	\$59.99	
7-Cell	#5502	\$69.99	
SCE			
4-Cell	#5503	\$48.00	
6-Cell	#5504	\$67.00	
7-Cell	#5505	\$77.00	

TRINITY Trinity Products, Inc.

1901 E. Linden Ave., #8, Linden, NJ 07036
(201) 862-1705 • FAX: (201) 862-6875

Trinity® Battery Rematching Service
Are your battery packs becoming weak? Send in your used cells and have them rematched. 48 cell minimum. Cells must be free of braid, solder, etc. \$1.50 per cell thru your local hobby shop, which also has further info on the service.



TRASH THE COMPETITION!

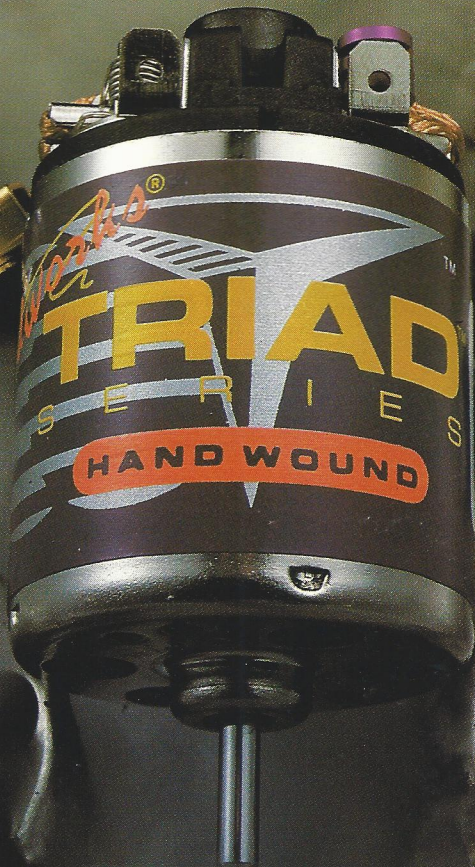

The ALL NEW
Speedworks

TRIAD SERIES HAND WOUND, MODIFIED MOTORS

- Hand wound, modified armature
- Adjustable timing
- Composite, hi-temp endbell material
- Brush heat sinks
- Precision ball bearings
- 2-stage wet magnets. 4.0

\$59.99
ROAR
LEGAL!

50,000 rpm 9 turns #0666	49,000 rpm 10 turns #0667	46,000 rpm 11 turns #0668	43,000 rpm 12 turns #0669	41,000 rpm 13 turns #0670
--------------------------------	---------------------------------	---------------------------------	---------------------------------	---------------------------------

"NOW YOU DON'T HAVE TO SPEND
A FORTUNE TO FINISH ON TOP"

TRINITY Trinity Products, Inc.
1901 E. Linden Ave., #8, Linden, NJ 07036 • (201) 862-1705 • FAX: (201) 862-6875



CAL-ORE OFF ROAD CHAMPS

June 30 & July 1, 1990

**Start the 90's racing in our Mountain Air and enjoy the
Best Small Town 4th of July Celebration in California!**

LOCATION: Mt. Shasta R/C Raceway, Lassen Lane & I-5, Mt. Shasta, California. Only 4 hours north of Sacramento or S.F. Bay Area, 5½ hours south of Portland. Call 916/926-4717 for more info or write.

ENTRY FEE: \$25.00 First Class (includes fluorescent Team Hat), \$10.00 Second Class

DEADLINE: June 25th, 1990

ROAR SANCTIONED

LODGING: Camping, RVs, Motels and Food Nearby.

THE TRACK: Mt. Shasta R/C Raceway 80'x130'. Computer Scoring with backup computer.

TROPHIES: All A-Main Drivers; Places 1 to 3 other Mains, Concours.

FORMAT: Sat. 12-5 Practice & Hot Laps Qualifying; Sun. 9-5 Heats & Mains.

CLASSES: STOCK (6 cells & ROAR STOCK MOTOR), MODIFIED (6 or 7 cells and Modified Motor); 2WD, 4WD, STOCK MONSTER TRUCK, MODIFIED MONSTER TRUCK.

sponsored by:



ENTRY FORM

Due June 25, 1990

Checks Payable to: Dan's R/C Racing
Mail to: Mt. Shasta R/C Racers
826 Pine Street
Mt. Shasta, CA 96067

NAME _____
LAST FIRST
 ADDRESS _____ PHONE _____
 CITY _____ STATE _____ ZIP _____ ROAR # _____
 CLASS 1) _____ Frequency 1st _____ 2nd _____ 3rd _____
 2) _____ (Red, Blue, 72, 64, etc.) _____

**ROAR Membership Required
Available at Track**

more aggressive. It turns in better but is not quite as stable exiting turns under power. You can partially compensate by adding rear toe in with H-arms but overall the car is TRICKIER to drive fast. The 5-link in contrast has more rear bite, is more forgiving, and especially with the new shorter rear toe-in links tends to lock-in the rear end on exiting the turns. It's easier to drive fast!

Changing between the two is pretty easy. So analyze the track and install H-arms or 5-link as needed. Don't forget to adjust FRONT toe-in depending on the type of rear end you choose. With H-arms use front tires straight (max steering) to slight toe in (max front-end push), 5-link - Front slight TOE OUT (max steering) to straight (push). Small adjustments go far on the JRx2.

Now you can fine tune the car. Adjusting towards MORE TOE-IN gives more PUSH in the front end and makes the car more forgiving. If more high speed steering is desired, more front negative camber up to 5 degrees can be adjusted in. You can also adjust rear toe-in and anti-squat. The recommended H-arm set up is the number 1 pivot support with 6 degrees toe-in and 4 degrees anti-squat. This is MAX toe-in-Anti-squat and gives the best hard acceleration traction. If the track is pretty smooth with large radius turns, you may want to consider decreasing the anti-squat or toe-in.

I recommend making one suspension adjustment, then putting a fresh battery pack in the car and having someone time you for 4 sets of 3 laps each before making another adjustment. This will allow you to get a feel for the car and also give you an objective means of comparing performance by comparing lap times in the groups of 3 laps with lap times after the next adjustment. Be sure to have your timer note if you crash during each group of 3 laps to make the comparisons real. (You may want to forget that group). Ease of con-

DAHM'S™

DAHM'S RACING BODIES

P.O. BOX 360, COTATI, CA 94931 (707) 792-1316
21 NEW PRODUCTS! SEND \$2.00 FOR NEW CATALOG AND DECALS



1.

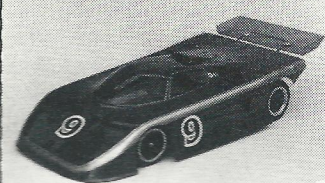

2.

1. AVENGER 2000™
2. FIREBIRD GTP
3. WARRIOR II™
4. STARFIGHTER™
(AEROSTAR)
5. THRILLER™
(NISSAN)
6. TUFF-E NUFFT™
(FORD RANGER)

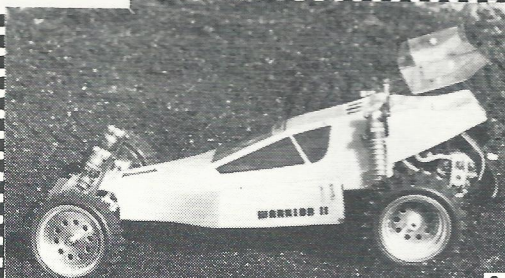

3.



4.



5.

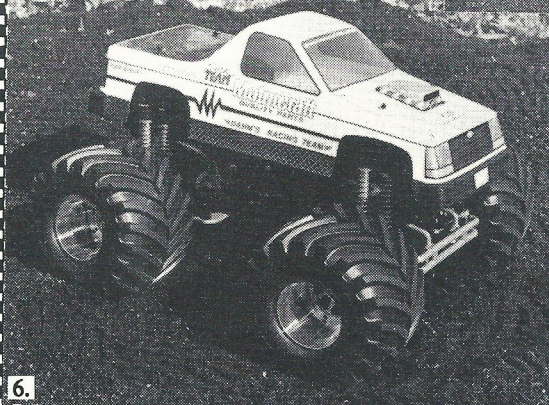

6.

DAHM'S FOUR NEW RACING TRUCK BODIES FIT MOST 10TH SCALE CARS FROM THE RC10L TO THE CLODBUSTER! TAKE YOUR CHOICE: MONSTER TRUCKS, MUD BOGGERS, PULLERS, VANS, DRAG TRUCKS, PANEL TRUCKS, LOW RIDING STREET TRUCKS PLUS A VAN FROM THE FUTURE!

DAHM'S LONG, LOW, LEAN AND MEAN WARRIOR II™ IS THE NEWEST RACING BODY FOR THE RC10 AND FITS MOST OTHER 2WD CARS. WARRIOR II POWER PAN™ IMPROVES AERODYNAMICS AND KEEPS THE DIRT OUT! DAHM'S MONSTER POWER PAN™ (LEXAN UNDERBODY) FITS MOST MONSTER CONVERSIONS, AND INCLUDES A SUPERCHARGER! DAHM'S NEW FIREBIRD GTP INCLUDES A FREE WING, AND WILL MAKE YOUR 12TH SCALE CARS LOOK AND HANDLE GREAT. DAHM'S NEW ADJUSTIBLE, BI-LEVEL, LEXAN FX™ WINGS ARE A MUST FOR ALL 8TH, 10TH, AND 12TH SCALE R/C RACING CARS. GET YOURS TODAY!

ASK FOR DAHM'S NEW PRODUCTS AT YOUR LOCAL HOBBY SHOP OR RACE TRACK. OR CALL 707-792-1316. EXPERIENCE THE EXCITEMENT!™

IT'S WINNIN' TIME!

Winnin' time is Reedy time when it comes to winning World Championships.

Mike Reedy is the all-time all star for matched packs of Sanyos with the power and run time the experts demand.

The secret to Mike's winning ways is simple...balanced and computer matched batteries and custom wound and balanced

motors are critical in World Class competition. And Reedy Power Matched Packs are the perfect match for Reedy Modified racing motors.

Just look at the record.

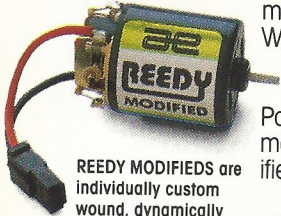

REEDY MODIFIEDS are individually custom wound, dynamically balanced, timed and dyno-tuned to win.

T H E R E C O R D

1982-83	IFMAR World Champion	1:12 Scale
1984-85	IFMAR World Champion	1:12 Scale
1985-86	IFMAR World Champion	1:10 Scale
1986-87	IFMAR World Champion	1:12 Scale
1988-89	IFMAR World Champion	1:12 Scale

Cycled, tested, recycled and evaluated individually in the Reedy motor labs using the secret techniques that have won more World Titles than all the others combined. All cells must meet minimum requirements. Those that don't cannot get the Reedy label. Mike Reedy is a very fussy fellow. And this is how he rates his cells:

REEDY POWER MATCHED PACKS

Great	(Fast)	Factory Packs	(White label)
Better	(Faster)	Racer Packs	(Silver label)
Best	(Fastest)	Team Packs	(Gold label)

All packs are factory sealed and shrink wrapped for your protection.

Reedy Power Matched Packs are now available in the latest Sanyo Cadnica SCE and SCR cells. Six and Seven cell configurations give you winning Reedy Power for offroad, oval and road racing.

Let Mike Reedy perform his magic act on your race car. Reedy Power Matched Packs give you the power AND the extra run time it takes to win.

GENUINE REEDY POWER Matched Packs are factory shrink wrapped to assure top performance and quality.

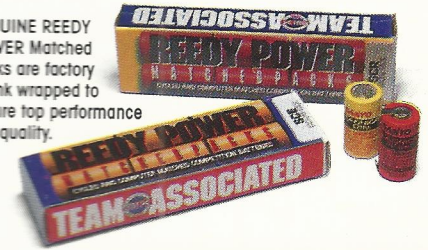

Associated Electrics
3585 Cadillac Avenue, Costa Mesa, CA 92626

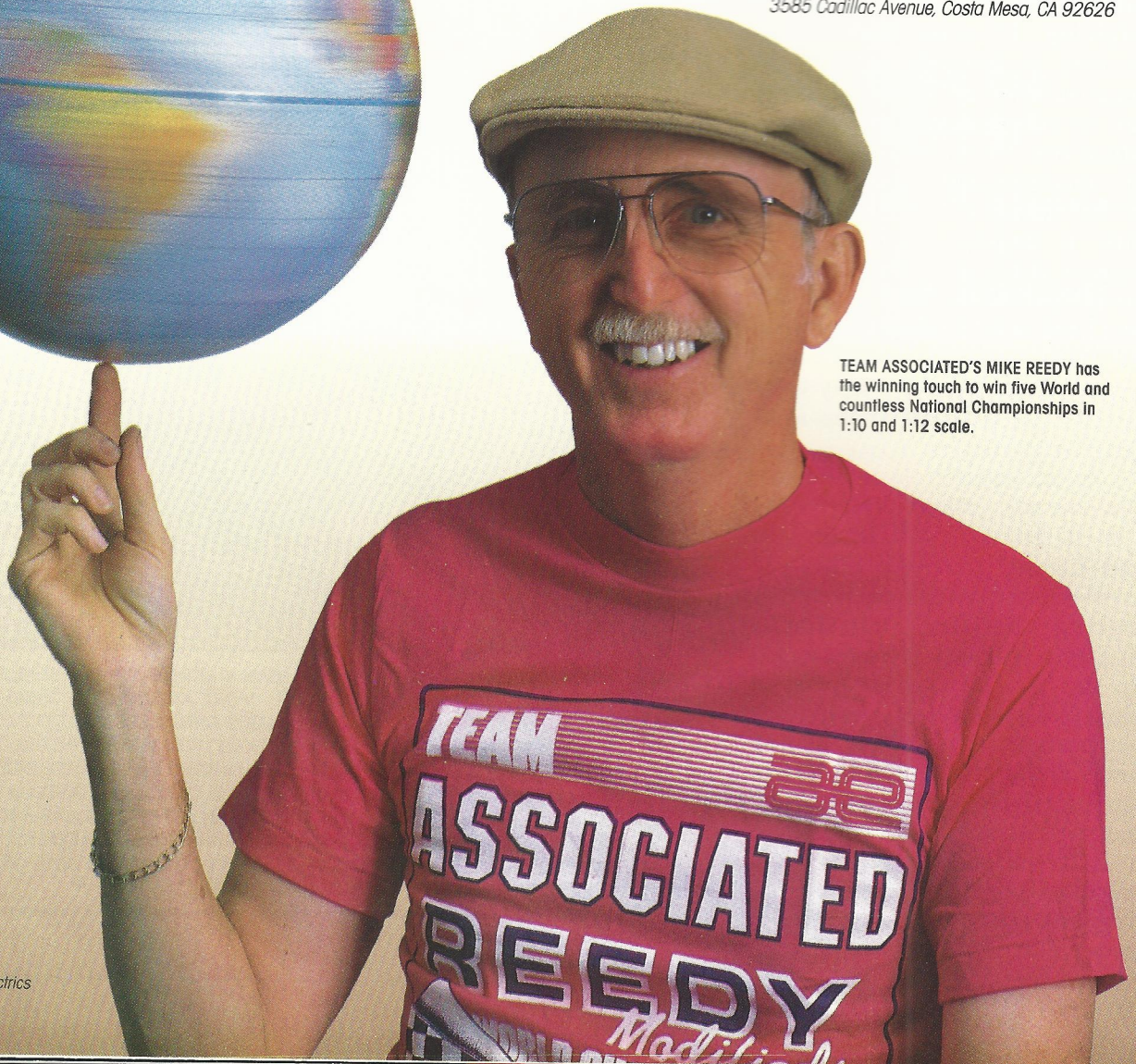
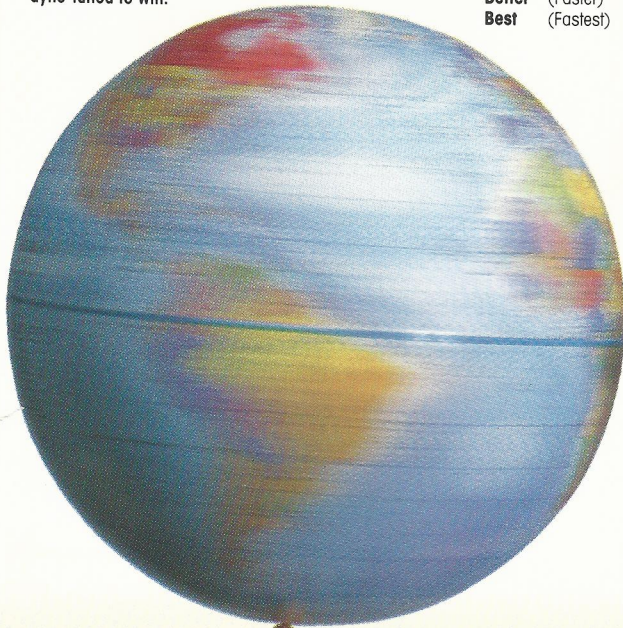

TEAM ASSOCIATED'S MIKE REEDY has the winning touch to win five World and countless National Championships in 1:10 and 1:12 scale.

trol and lap times will tell you what works best.

If there's one section or turn on the track you're having problems with don't be afraid to walk out and examine it closely and then practice on just that section over and over again if you can. If "practice makes perfect", you don't really need as much on the part of the track you're already good at!

All of the cushion carcass tires that I have tried are excellent with the X-spike pattern or the clipped directional rears providing the most traction and the 5 row rears a little less traction. Overall the 4 row or 5 row high traction tires are hard to beat.

We all know that a champion driver's most important skill is to read and drive the track on the smoothest and quickest line. This takes practice but it also takes a great car. Right now the best 10th scale 2 wheel drive off road car available is the JRx2 with their Performance Kit. With any "LUCK" at all, 1990 will

"HOT LAP"
DISTRIBUTOR

3080 West 96th Avenue • Westminster, CO 80030
303/428-6132

**1/8 SCALE
GAS CARS**

- Cobra III Parts • Delta Parts
- Hot Laps Racing Fuel • Tires
- New Sonic Filters • Pinzini Motors
- New High Temp Exhaust Tubing

**ELECTRIC 1/10-1/12
SCALE CARS**

- Delta Parts • Super Slick Oil
- Hot Laps Tire Traction "Grip"
- Peak Performance Motors • Tires

SEND \$4.00 FOR CATALOG

bring us a production version of Team Associated's prototype RC10 so we can compare these head to head in their production versions. As usual the real winners will be all of us racers!

So that's how to set up a PRO JRx2 in 1990. Look for new light but strong dish wheels as soon as Team Losi continues to "grow" the JRx2. Thanks to Tecnacraft, Tekin, Gary Kyes and congratulations to Team Losi for redefining state-of-the-art.

□CP

**Don't Make
A Move**

Without Us!

**Subscriber: Please notify us
of your new mailing address
four weeks prior to moving.**

**FINE DESIGN
MFG. CO., INC.**
2 NORTH STREET
MIDDLETOWN, N.Y. 10940 USA

FDM



FIREFOX

THE STRAIGHT LINE CO.

FIREFOX SHATTERS ALL RECORDS AGAIN !!!

THE 1st IDEA WINTER NATIONALS ■ JAN. 20-21 ■ COTTEN CALIF.

- TOP FUEL RAIL DRAGSTER* 20** CELL - 1.82 SEC. 70.9 MPH *KIT 2028
- TOP FUEL FUNNY CAR* 14** CELL - 2.18 SEC. 63.88 MPH *KIT 2022
- ALCOHOL RAIL* 10** CELL - 2.18 SEC. *KIT 2029
- LOW E.T. OF EVENT - 1.82 SEC.**
- HIGH M.P.H. - 70.9 MPH**

ADD THIS TO OUR 6 R.O.A.R. NATIONAL RECORDS AND FIREFOX STANDS UNDEFEATED IN THE DRAG RACING WORLD. CONGRATULATIONS TO ALL FIREFOX DRIVERS WHO HAVE CHOSEN THE WINNING EDGE.

CALL TODAY FOR OUT 1 H.P. MOTOR !

THE NATIONAL RECORD HOLDER FOR LOW E.T.

See Your Local Hobby Shop or Call Direct (914) 342-5102 ■ Distributed by Great Plains - ERI - Speed Sport - Carribean Hobbies

Pacific Coast Offroad Championship

June 15 - 17, 1990

REVTECH

Hosted by
Racers Haven
Bakersfield, CA

NOVAK
ELECTRONICS

SCAT
RACING PRODUCTS

The Triple Match
Standing Matched Batteries

Andy's

R/C PRODUCTS

- What** Racers Haven proudly presents one of the most prestigious Offroad races of the year. Commitments have already been received by several top racers in the United States. Don't miss this opportunity to compete against the nation's finest, send your entries now.
- When** Friday, June 15: Open practice 10am-10pm
Saturday, June 16: 3 rounds qualifying, 10am. Practice ends 9am
Sunday, June 17: Concourse, 1 round qualifying, and Mains, 9am
- Classes** 2WD Stock, 2WD Open, 4WD Stock, 4WD Open, Trucks Stock, Trucks Open
- Awards** A-Mains 1st-10th, and 1st - 3rd all other classes. Concourse to winner.
- Track** Long course with wide 10-14 foot lanes. Covered pit areas with pit tables and electric outlets to accomodate 250 entries. Food and beverage available on the premises.
- Hotel** Travel Lodge Plaza Inn 1030 Wible Rd. Bakersfield, CA (805)834-3377
- Rules** ROAR rules apply
- Entry Fee** Pre-Entries by June 8: \$20 for 1st class, \$14 each additional class. Entries postmarked after June 3, add \$5 per entry. Maximum 3 entries per racer.
- Information** For more information and entry confirmation: Mail a 4x9 S.A.S.E. to Racers Haven.

Detach entry form and mail to: Racers Haven 7401 White Lane #9 . Bakersfield, CA 93309 . (805)835-0441

Pacific Coast Offroad Championships June 15 - 17

Name _____ Phone _____
Address _____ City _____ State _____ Zip _____
Classes: 1. _____ Frequencies 1. _____ 2. _____ 3. _____
2. _____ Frequencies 1. _____ 2. _____ 3. _____
3. _____ Frequencies 1. _____ 2. _____ 3. _____

Make checks payable to Racers Haven. Total amount enclosed: \$ _____

I am unable to attend this race, but please send me information about your racetracks and facilities.

(Continued From Page 40)

in the first qualifier. Jimmy Pullon came close to breaking 10 laps with a 10 lap 4:01 performance to lead the 4WD Stock field.

Mike Ankney's TQ honors held up through the beginning of the second qualifier for the 2WD A drivers. But two other drivers turned 11 laps up to that point to narrow Mike's advantage. Mike responded by bettering his TQ mark by a full three seconds pushing him near the 12 lap mark. John Lawson finally brought an 11 lap performance to the 4WD field taking the TQ honors there with an 11 lap 4:19 run. Both drivers would maintain the TQ distinction through the remaining qualifiers.

The 2WD Stock A Main was an exciting race from start to finish if you excluded TQ Ankney. Mike, as he did in all three qualifiers, lead from start to finish. The rest of the field, however; was locked in a fierce struggle as 2nd through 8th place was separated by less than 15 seconds through the first three minutes of the race. Second through fifth place was decided on the last lap. Below is the results of the 2WD Stock A Main:

2WD MAINS

A Main

- 1st - Mike AnkneyT/Q
- 2nd - Pat McCreary
- 3rd - John Lawson
- 4th - Greg Klugh
- 5th - Dean Karns
- 6th - Mike Marshall
- 7th - Jim Bronson
- 8th - Richard Love
- 9th - Wayne Gerber
- 10th - Mike Hampton

B Main

- 1st - Joe Kolp
- 2nd - Jason Edwards
- 3rd - Kenney Thorton

C Main

- 1st - Jim Pullon
- 2nd - Snake Whitaker
- 3rd - Chad Mortimer

D Main

- 1st - Rick Cann
- 2nd - Chris Smith
- 3rd - Ron Westkamp

E Main

- 1st - Dave Mott
- 2nd - Luther Griffin
- 3rd - William McCauley

F Main

- 1st - Steve Lafara

2nd - Zack McNealy

3rd - Bob Curtis

G Main

1st - Rich Weiss

2nd - John Kemp

3rd - Jay Maxwell

H Main

1st - Dan Zfela

2nd - Matt Dewitt

3rd - Ralph Gerkins

I Main

1st - Tom Prince

2nd - Greg Thelm

3rd - Mike Winders

J Main

1st - John Holzer

2nd - Dave Reiman

3rd - Troy Brandt

K Main

1st - Jason Corn

2nd - Ray Takahashi

3rd - Tim Fogelson

L Main

1st - Jerry Benson

2nd - William Dayton

3rd - Randy Bowling

M Main

1st - Steve Smith

2nd - Larry Riggins

3rd - Shaw Takahashi

N Main

1st - Scott Clark

2nd - Darin Kreilach

3rd - Bill McCall

O Main

1st - Jack Neary

2nd - Mike Nicholas

3rd - Brent Sheppard

P Main

1st - Steve Albert

2nd - Andy Kish

3rd - Mark Bettinger

As in the qualifiers, John Lawson just made it past the finish line for the 10th time as the time expired leaving him with a victory laps of sorts. The one 1.07

seconds that John led Jim Pullon by as time expired was enough to give John the 4WD Stock title. Here is how the 4WD Stock A Main ended:

4WD MAINS

A Main

- 1st - John LawsonT/Q
- 2nd - Jim Pullon
- 3rd - Randy Coleman
- 4th - Tim Wolski
- 5th - BJ Zacharias
- 6th - Brett Polivka
- 7th - Mark Hull
- 8th - Darren Williamson
- 9th - Scott Michael
- 10th - Matt Moritz

B Main

- 1st - Bob Nedved
- 2nd - Jeremy Bardell
- 3rd - Dave Martini

C Main

- 1st - Dan Miller
- 2nd - Fred Price
- 3rd - George Stanley

When the Modified qualifying began on Sunday further evidence was offered to the stated opinion that suspension setup was deciding the winners on this track. The cars that could take the wide array of jumps that the track offered were leaving the rest of the field behind. Once again the only 11 lap performances put in during the first rounds was by Mike Ankney in 2WD and John Lawson in 4WD. To add to the point, both drivers' TQ marks were within 5 seconds of their Stock TQ marks. Ankney was unable to better that mark in the

THE CONTROL ROOM

R/C is Red Hot!

Full Color

POSTERS, DECALS, SHIRTS, ETC...

For more information ask your Dealer
Or send self addressed stamped envelope
to THE CONTROL ROOM: 1334-D N Benson Dept. C
Upland CA 91786 714-987-3838 714-985-9700

Modeler's Haven

"Experienced Racers You Can Trust"

Call Us First For Those Hard To Find

R/C Car Parts & Accessories

PHONE (216) 499-6000 FAX (216) 499-6087

PROMPT SAME DAY UPS SHIPPING

VISA - MASTER CARD - DISCOVER CARD

"Leave Others Behind - At The Start Line"

WITH TURBO MADNESS - COMPUTER MATCHED BATTERIES

4255 Portage N. W., North Canton, OH 44720

remaining qualifiers but it did hold up for TQ honors though. He was joined in the 11 lap bracket by Mike Marshall who came within 6 seconds of Ankney's spot.

In the latter 4WD qualifiers, John Lawson was bettered by Tony Hines in the third round to take the TQ position with an 11 lap 4:11.62 run. Randy Coleman also had an 11 lap race in the third round making the 4WD A Main the only one to have more than one 11 lap performer in the field.

As the qualifiers for Mike Ankney went so went the 2WD Modified A Main. Mike led by a small margin over Mike Marshall after one lap but all weekend nobody was able to pass Ankney once his lead was established. Marshall and Pat McCreary made it closer but it was not to happen this weekend.

2WD MODIFIED MAINS

A Main

- 1st - Mike AnkneyT/Q
- 2nd - Mike Marshall
- 3rd - Pat McCreary
- 4th - Greg Klugh
- 5th - Conan Honeck
- 6th - Dean Karnes
- 7th - Scott Moody
- 8th - Brian Fields
- 9th - Jason Edwards
- 10th - Richard Love

B Main

- 1st - Jason Corm
- 2nd - Rex Gillespie
- 3rd - Dan Louis

C Main

- 1st - Andy Prince
- 2nd - Kenny Thornton
- 3rd - Bob Nedved

D Main

- 1st - Luther Griffin
- 2nd - Wayne Thomas
- 3rd - Jay Overman

E Main

- 1st - Chad Miller
- 2nd - John Buckley
- 3rd - Mike Winders

F Main

- 1st - Randy Kastl
- 2nd - Tim Wolski
- 3rd - Ron Dorfield

G Main

- 1st - Pat Barber
- 2nd - Jabo Hayes
- 3rd - Brian Boone

H Main

- 1st - Butch Eaches
- 2nd - Mike Meyer
- 3rd - Bill Steinbrook

John Lawson got off to a fast start along with Harold Taylor in the 4WD A Modified main. TQ Hines got off to a bad start and that was enough to leave him with the finish line between him and the leaders when time expired. John Lawson managed to pull away from Taylor on 8 of 11 laps run to give him the title. Here's how the field ended the final race of the event:

4WD MODIFIED MAINS

A Main

- 1st - John Lawson
- 2nd - Harold Taylor
- 3rd - Terry Peabody
- 4th - Tony HinesT/Q
- 5th - Phil Zimmerman
- 6th - Tim Wolski
- 7th - Randy Coleman
- 8th - Jason Conley
- 9th - Mike Hampton
- 10th - Brian Howell

B Main

- 1st - Steve Lafara

2nd - Brett Polvika

3rd - Scott Melcher

C Main

1st - Shaw Takahashi

2nd - Brent Weher

3rd - Sumio Takahashi

D Main

1st - Rob Passerelli

2nd - Robert Tribe

3rd - Paul Marizana

This year CORCAR would like to extend a special thanks to the racers who participated in the weekend's races. We attempt to give the racer the finest races possible but it is the quality field that is making this event one of the finest indoor off-road races in the nation. We would like to extend an invitation to all ROAR racers to attend the '91 event.

FULL SCALE MONSTER TRUCK!

Great Planes Model Distributors Company, Champaign, IL, is proud to announce a first in the history of Monster Truck Racing! (Full-Scale, that is.) Great Planes has entered into an agreement with an Illinois-based racing team to construct a full size replica of the 1/10 scale Kyosho Big Boss R/C Monster Truck. Currently under construction, this new Monster Truck will be powered by a 429 cu. in. supercharged Ford V-8 producing over 800 horsepower!! Other features include a tube frame and fiberglass 1986 Ford F250 body which will be painted to match the Kyosho model. The Full-Scale Big Boss will be competing at over 50 Monster Truck Racing events around the country including some of the United States Hot Rod Association (USHRA) events.

The new Big Boss is sponsored by Kyosho as is the "Heavy Metal" Monster Tank, a 1951 Ford F100 mounted on a M-45 tank chassis. This is just a part of Great Planes' ongoing commitment to bring the excitement of Radio Control to audiences previously untapped by the R/C industry!

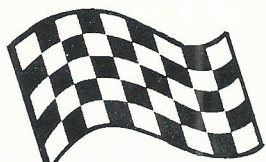

TECH-TOYS

Radio Controlled



Grand Prix

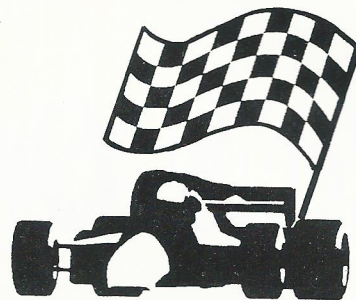

During the Marlboro Grand Prix at the Meadowlands

July 13, 14, 15

Brendan Byrne Arena

Meadowlands Sports Complex, East Rutherford, NJ

1/10th scale on-road pan cars ONLY

- Stock
- Modified

Indy or Formula One bodies ONLY

Bolink Lap Counter

Track layout: scaled, carpeted duplicate of Grand Prix Course

2 rounds and the mains

Indoor- Rain or Shine

Registration:

\$40.00 modified

\$50.00 stock (Includes Motor)

• Includes 3 day full-scale race admission and reserved grandstand seating

• Special discount ticket rates for full scale Marlboro Grand Prix

• Premium seating for Marlboro Grand Prix available at discount rate. Call for details

Trophies • Jackets • Hats • Prizes • Pins • Celebrity Pro Drivers

SPECIAL AWARD: 1ST PLACE A MAIN WINNERS RIDE IN THE GRAND PRIX PACE CAR



Special Manufacturer Concourse Prizes

Static Concourse & Running Concourse

For information and discount ticket purchases contact::

Tech-Toys, 370 Rt 46 W.

Parsippany, NJ 07054

(201) 227-7012

Host Hotels:

Quality Inn, Lyndhurst, (201) 933-9800

Holiday Inn, Hasbrouck Heights, (201) 288-9600

ask for Grand Prix Rate

Entry Deadline June 30, 1990

Name _____

Frequency 1. _____ 2. _____ 3. _____

Address _____

Class _____

Phone _____

Additional Marlboro Grand Prix Discount
Tickets Required @ \$27.00 ea. (save \$3)

Please make check payable to Tech Toys Grand Prix and send to: Tech Toys, 370 Route 46 W., Parsippany, NJ 07054
No entry refunds are possible.

Triad Takes Reedy Oval Race of Champions



Andy Dobson was the winner of the Reedy Oval Invitational Class. Andy was driving a Lynx/Trinity Combination.

If you haven't yet experienced one of the true spectacles of our sport, you must go to Lake Whippoorwill. The professionalism of Bob Horsch and the crew is to be commended. I feel that they bring a new standard to R/C racing. All you hear about The Whip is true, and more! The announcing was very entertain-

ing, in fact, they reminded me of Mark and Brian (two very funny L.A. morning DJs). The pre-race ceremonies included concourse, a car line-up, interviews, and even the National Anthem. Truly a class event!

The Invitational Class featured the 25 best drivers in 1/10th Paved Oval. The program for this

class was a little different from the Reedy Off-Road Race. They were going to run eight main events, like off-road with two throw outs. The difference was in the last round. There would be no throw out in this heat. The ten drivers with the lowest points would be put together in one
(Continued on Page 79)

FUTABA'S

MAGNUM FORCE

By Jeff Palmer



PCM's Control Center. Note the various settings.



OFF ROAD HEADQUARTERS

PRIZES

RADIO CONTROL RACEWAY

INVITES YOU TO ATTEND THE

1990 REGION ONE OFFROAD CHAMPIONSHIP

***** WARM-UP RACES HELD FIRST SUNDAY OF EACH MONTH*****

SCHEDULE

Friday, August 24

Open 12 noon
Practice 12:00 to 8:30 p.m.
Drivers Meeting 9:00 p.m.
Drivers Must Attend

Saturday, August 25

2 wd Stock & Open
Open 8 a.m.
Checkin 8 a.m. to 9:30 a.m.
2 qualifiers, 10 a.m. to 2 p.m.

4 wd Stock & Open
Checkin 2 p.m. to 3:30 p.m.
2 qualifiers, 4 p.m. to 8 p.m.

Sunday, August 26

Open 8 a.m.
3rd Qualifier and All Mains
First Heat Starts at 9 a.m.
TROPHY PRESENTATION

DEADLINE August 17, 1990

ROAR MEMBERSHIP REQUIRED
(available at track)

ROAR RULES APPLY

ENTRY FEE (no refunds)
\$25 Modified per class
\$35 Stock per class
w/handout motors

Pre-registration Required
No Phone In's
Limit 300 Entries

TROPHIES
A Main - 1st to 10th
All other mains 1st to 3rd
TQ PLAQUES
Concourse 1st to 3rd

CLASSES

2wd Stock	Monster Truck
2wd Open	2wd stock
4wd Stock	2wd open
4wd Open	4wd stock
	4wd open

Information package will be mailed
Make checks payable to D HOTT

Entire Racing Surface will be soft and well maintained

OFFICIAL OFF-ROAD ENTRY FORM	
NAME _____	PHONE _____
ADDRESS _____	
CLASS(ES): 2W STOCK ___ 2W OPEN ___ 4W OPEN ___ 4W STOCK ___ Truck _____	
2W FREQUENCIES 1. _____ 2. _____ 3. _____	SKILL LEVEL _____
4W FREQUENCIES 1. _____ 2. _____ 3. _____	Beginner Novis Expert
FOR MORE INFORMATION CALL JEFF (301) 474-1246	
5640 K SUNNYSIDE AVE., BELTSVILLE, MD 20705	
ROAR # _____	

Futaba has been the leader and trend setter for R/C gear for the past decade and they refuse to be left behind by technology. In keeping up with technological advances, Futaba has replaced its legendary Magnum transmitter with a new pair of Magnums. The first Magnum, the PCM (Pulse Code Modulation) is a significant advancement in R/C technology. The second Magnum, the AM (Amplitude Modulation) version is an electronically updated continuance of R/C technology that has made Futaba a household name in R/C.

AM, FM or PCM?

To help develop a better understanding of the different types of transmitters, let's start with a simple problem: As the steering wheel on the transmitter is turned from full left to full right and back full left, voltage change is caused in the steering circuit. Since the purpose is to drive a servo, the voltage change is converted into "timed pulses" (graph 1a); the longer the pulse, the greater the servo horn movement to the right of center. Conversely, the shorter the pulse, the greater the movement of the servo horn to the left of center. These pulses are then combined



Futaba's Twins - but not identical

with the carrier signal of your transmitter, in other words, the carrier signal (graph 1b) is modulated using the "timed pulses" from the steering circuit. If the transmitter is an AM type, the amplitude of the signal would be changed. Graph 1c shows the results of AM modulation; notice how the carrier signal amplitude is changed as the steering wheel is moved. Also note that the fre-

quency did not change. The second transmitter type, Frequency Modulation (FM), uses different frequencies to represent changes. In graph 1d, the carrier signal or frequency is changed to a slightly lower frequency (full left) to a slightly higher frequency (full right). The increase and decrease of frequency in graph 1d is denoted by the space between the wave of the signal;

ERI
assoc., inc.

THE Electric R/C Car Specialist

(914) 268-5090
FAX
(914) 268-0462

OVER
130 Companies
Stocked

DEALERS
ONLY!!

Advanced X2	A&L	Litespeed	Losi	MCS	MIP	Stormer	S.T. (Skis)
Airtronics	Aerotrend	Max Industries	MPE	Monolithic Pow'r Supply	McAllister Minitech	T.A. Emerald Industries	Team Hammer Tekin
Andy's	Aristo-Craft	Miracle Speedway	MRP	Norcal Novak Pactra	Paragon Parma Pitstop	TeamSmoothTechnacraft	Thorp TM TMS Traxxas
Ascot	Associated	Peak Performance	Power Pak	Pro Line	Pro Cut	Protech Ram	Track Master TrinityTRC
Astro Flight	Autographics	Progressive Technology	Protrack	RaceMaster	RaceCo	Race Prep	Twinn-K Twister Ungar
Big Boy Toys	Blk Magic	Racing Silks	RC Perf. Spec.	RacingScaleSport	Revtech	RPM	You-G Universal Energy
Bold Creations	Bolink	RochesterRaceway	Rockbusters	Scat	Robinson Racing	Sassy Chassis	SRS
B&R	BRP	Sermos	Speedworks	Shinwa	Stage III	T&A	
Bondhus	Buline Bud's						
Cheetah Cam	Checkpt.						
C&M	CMW						
Composite Craft	Cobra						
Competition Electronics	CSC						
Dan's	Dahm's						
Delta	Dubro						
Dialed Racing	Fine Design						
Five Star	EdgeGonzo						
Great Grease	Houge						
Hot Trick	Hyperdrive						
Jammin' (JH) Products	Imex						
JG Kimbrough	J-Car						
KO Propo	KRP						
KSC	Lazerlite						
Lightspeed							

WHAT'S NEW?

1. Thorp BF telescoping axle kit,
2. Ultrasonic cleaners,
3. Twister-- Pocket Rockets,
4. Flourescent Race Cases,
5. Batmobile Body,
6. Thorp 48 pitch RC10 gear box,
7. JG Stadium Race Truck,
8. FRP brush alignment tool,
9. Marui Big Bears,
10. MCS brush cutting tool,
11. MIP Slippers.

NEW COMPANIES

Branson
(Ultrasonic Cleaners)
Bullet Racing ESP
Fast Racing Marui
Premier Designs
Redline Royal
Smokin'

If you do not see it here...just ask!

ASK YOUR HOBBY SHOP TO
CALL.... (914) 268-5090



The Only Difference Between The Motors In These Two Cars Is 318 lbs. & \$59,920.47

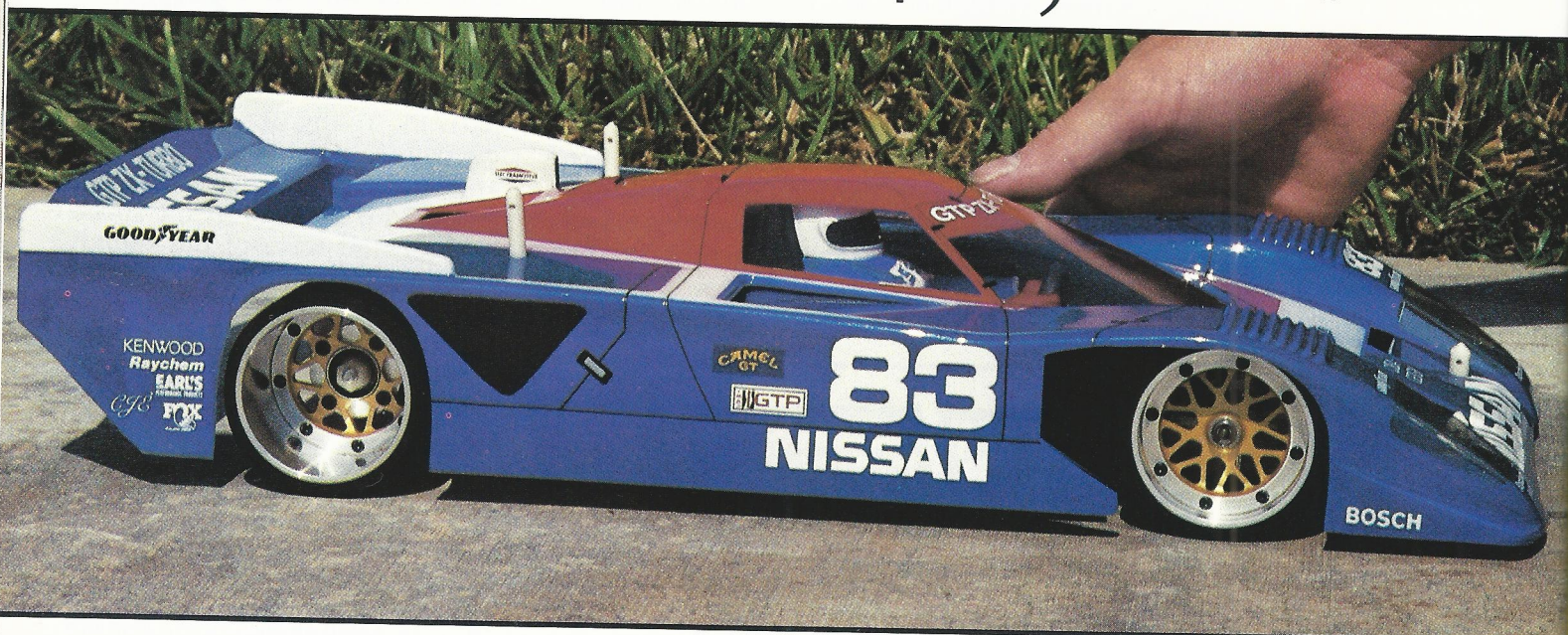

Well, maybe we're stretching the point a little bit here. The point you should remember is that Peak Performance builds their motors with the same kind of skill and high-technology thinking as "the big boys."

Because winning is the goal of every motor car enthusiast.

From our top quality stock motors to our twelve turn "BEAST" (our high-performance champion), Peak Performance is dedicated to building durability, speed and reliability into all our R/C car motors.

So if you're just as serious about your racing as we are, check out the full line of Peak Performance motors at your local hobby dealer today.

1986 & 1987 1/12th Scale Nat'l Champs
1988 1/10th Scale West German Champs
1988 & 1989 1/10th Scale Dirt Oval Nat'l Champs
1989 1/10th Scale On-Road Nat'l Champs
1989 1/10th Scale Australian Nat'l Champs
1989 1/12th Scale Swiss Nat'l Champs
1989 1/10th Scale Danish Champs

PEAK PERFORMANCE

1362 East Edinger, Building B • Santa Ana, CA 92705 USA
PHONE: 714-667-6865 FAX: 714-667-0858

TEKIN

COMPETITION R/C ELECTRONICS

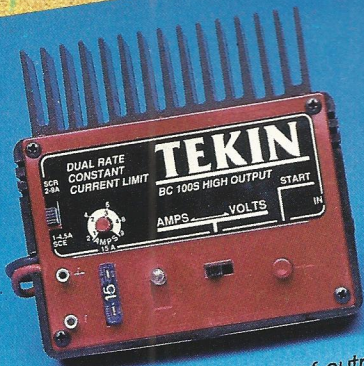

BC100S CHARGER - 2 types of output. Soft pulse for SCE cells, and hard pulse for SCRs. Get more power, life, and run time from your cells. From the inventors of peak detection charging.

TEMPFET SPEED CONTROLS

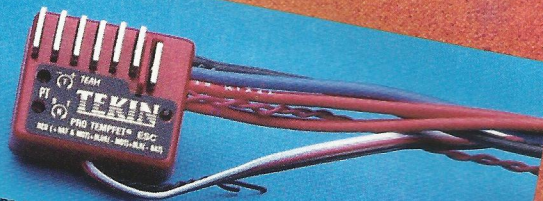

Competition type aftermarket speed controls handle high power modified motors. Tempfets mean no overheating; extra strong braking action. New BEC circuit design improves radio reception, especially with "BEC" Receivers. Model 600 has hand selected mosfets and now 13 gauge wire for absolute maximum power. Model 600 also now uses "Soft Pulse" motor current, so the motor runs cooler and develops more power. Smooth response improves driver performance. Mini size, lightweight, high performance, and reliable, dependable operation.



ESC REVERSE MODULE - Adds proportional reverse to most competition type ESCs. Simple and motors down to 17 turns. #ERM-80 Fut J, air, KO (Available December '89)

BATTERY PACK PEAK CHARGERS - Fully automatic, compact 9 amp peak chargers. Maximum power for any application. You can not get a better, more powerful charge. New, high capacity heat sink, adjustable current 1-9 amps, and works from a 12 volt battery, or a 12 volt automobile battery charger or power supply.

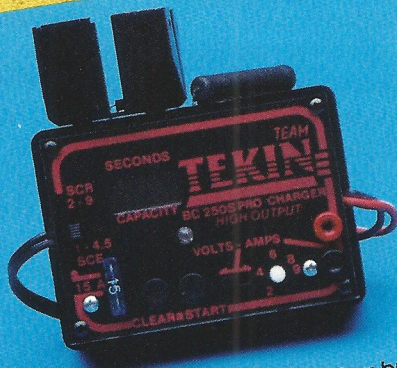

BATTERY CHARGER MODEL BC250S has built in digital coulomb meter to estimate battery capacity and run time each time you charge your pack. From the inventors of peak charging - now with soft pulse circuit.

COMING SOON NEW HIGH POWER ESC



ESC 700

NATIONAL AND WORLD CHAMPIONS

Everything we make is the best of its kind. For reliable, dependable, hassle-free equipment that delivers performance to compete at the highest levels, TEKIN is it.

MADE IN U.S.A.

TEKIN ELECTRONICS, INC.
970 Negocio • San Clemente, CA 92672 • U.S.A.
(714) 498-9518 FAX (714) 498-6339

Available at competition oriented hobby shops everywhere.

**NEW
PRODUCTS**

TURBO-GLIDE

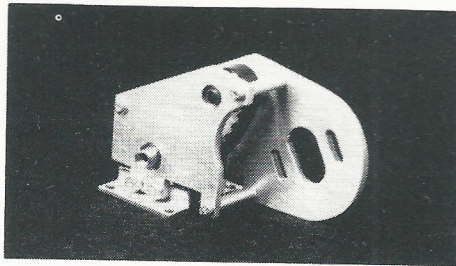

JRX-2 & JRX-T BELT DRIVE TRANSMISSIONS

A PROVEN WINNER! IN ITS TESTING STAGES THE TURBO-GLIDE HAS TQ'ed AND WON AT LOCAL, REGIONAL AND EVEN NATIONAL EVENTS. THIS 1/5 PITCH BELT DRIVE TRANSMISSION FEATURES A FULLY ADJUSTABLE BALL DIFFERENTIAL. NOW AVAILABLE FOR THE JRX-2 AND JRX-T, IN ALUMINUM OR GRAPHITE. THESE TRANSMISSIONS ALLOW A LARGER RANGE OF GEAR RATIOS THAN THE STOCK TRANS. THE BELT DRIVE TRANSMISSIONS FOR THE JRX-2 AND JRX-T ALLOW GEAR RATIOS FROM 4.7 TO 1 THROUGH 15.1 TO 1 AND USE STANDARD SPUR GEARS.



TRM4300 ALUMINUM BEARING TRANSMISSION FOR JRX-2 AND JRX-T.....	\$128.95
TRM4301 GRAPHITE BEARING TRANSMISSION FOR JRX-2 AND JRX-T.....	\$148.95

TRACK MASTER, 1466 PIONEER WAY, # 10, EL CAJON, CA 92020 (619) 442-0766

advantages and disadvantages of FM. Well, the reason is, in the world of R/C there is only two types of transmitters, AM and FM, and Futaba's PCM is an FM transmitter with a digital twist. PCM is actually an advanced encoding method for digital signals which uses FM for its transmission. Going back to our earlier problem, as changes were made with the steering wheel, PCM converts (encodes) these movements into digital pulses (graph 1e). It may not be evident from graph 1e, but timing is one of the characteristics of PCM. Every 1/20th of a second, the controls are sampled and this information is sent to the receiver. Each series of pulses represents information to the PCM computer. The series of pulses at the left of graph 1e represents the command to turn full left while the pulses to the center of the graph represent the command to turn full right. What is not seen in the graph is the series of commands that stepped the servo through intermediate portions of the left and right turns.

THINGS IN COMMON

Up to now we've discussed the two types of transmitters and each of their theories of operation, so let's turn our attention to Futaba's excellent offerings. To begin with, let's look at what controls they have in common. Start by examining the face of the two units,- the steering wheel, level meter, pilot lamp, on/off button, steering angle adjuster, throttle alt knob, throttle trigger, and the panel door all stand out as similarities. These controls have all been seen before as they were the controls on the old Magnum. The PILOT lamp will light red when the power is turned on and the LEVEL METER will indicate the relative amount of battery power being supplied to the transmitter. The STEERING WHEEL is the most obvious control on the face of the transmitter but the STEERING ANGLE ADJUSTER is the least obvious. All of us know that the

the closer the peaks, the higher the frequency. Conversely, the further apart the peaks, the lower the signal. In short, as the voltage is changed in the steering circuit, the AM transmitter changes the strength of its signal and the FM transmitter changes its frequency.

Now, let's relate the above paragraph to the world we live in - sometimes frequencies interfere with one another, altering its wave form or amplitude. Since specific frequencies are used in FM transmitters to represent control changes, amplitude changes are ignored. However, any high energy magnetic field, like an air conditioner or heater blower motor, microwaves, high powered CBs or commercial transmitters can disrupt or alter your transmitters signal to the point of making it unintelligible to the receiver whether it's AM or FM. One final note, the cost of building an FM transmitter and receiver is greater than that of similar AM units, since the FM units have to be able to handle multiple frequencies.

You may be asking yourself at this point why did we just spend



PCM's throttle trim. Use your thumb!

a lot of time discussing the

SCORE PRESENTS THE 1990 REGION 2 OFF-ROAD 1/10 SCALE CHAMPIONSHIPS

SPONSORED BY THE HOBBY SHOP AND SAVANNAH SKATE & HOBBY

SAVANNAH, GEORGIA - 29 JUNE TO 1 JULY

ROAR SANCTIONED - LEVEL 4 EVENT - #029008



STAGE III



imex

PRO-LINE

DAN'S RC Stuff

AutoGraphics

TEAM LOSI PERFORMANCE

TEKIN

parma INTERNATIONAL RC



PARAGON

HOUGE ENTERPRISES

HotTrick

SANYO

REEDY Modifieds

THE 1989 CHAMPIONS:
 2 WD STK - GREG RHODES
 2 WD MOD - EDWIN McTUREOUS
 4 WD MOD - EDWIN McTUREOUS

AGGRESSIVE RACING PARTS

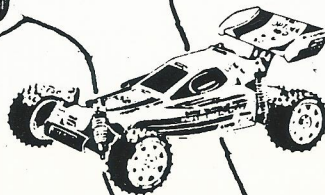
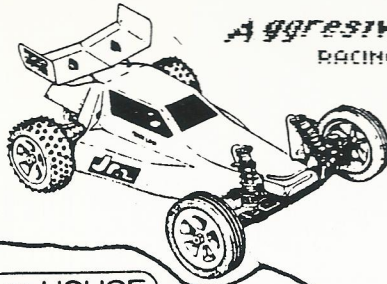

JM mfg.
SAVANNAH

WISER

COMPETITION PLUS THE R/C CAR MAGAZINE



NOVAK ELECTRONICS

RPM SCAT

PEAK PERFORMANCE

COMPOSITE CRAFT

TEAM ASSOCIATED

Andy's

BUD'S RACING PRODUCTS

TRINITY

Futaba

PERMANENT MARSHALS - MANY DOOR PRIZES - T SHIRT TO EACH ENTRANT

LOCATION: Lake Mayer Raceway, Lake Mayer Park, Montgomery Crossroads, Savannah, Georgia.

CLASSES: Two and Four Wheel Drive Stock - Two and Four Wheel Drive Modified.

FEES: Stock \$40.00 with handout motor. Modified \$30.00. Additional motors \$15.00 (limit two).

Additional T-shirts \$10.00. Late entry \$5.00. No refunds. Transfer of entry is permitted.

AWARDS: Trophies for; Top Qualifier in each class, A mains 1-10, other mains 1-3 and Concours 1-3.

ENTRIES: Limited to the first 350 cars. Driver may enter any two classes.

RULES: ROAR rules will apply. ROAR membership is required. Must show card or join at the race.

SCORING: AMB lap counting, KAYPRO KC-1 computer and AUTOSCORE race management program.

INFORMATION: Packet containing rules, schedule, maps and lodging information sent on receipt of entry form. For additional information, contact Phil Hurd at (912) 355-6033.

OFFICIAL ENTRY FORM

ENTRY DEADLINE: JUNE 25th

Name: _____ ROAR #: _____ Exp date: _____

Address: _____ City: _____ State: _____ Zip: _____

Phone #: (____) _____ Affiliation/Sponsor: _____

	1st Ch	2nd Ch	3rd Ch
2 WD STK			
4 WD STK			
2 WD MOD			
4 WD MOD			

For stock entries, how many extra motors? _____

PLEASE CHECK CLASSES DESIRED AND ENTER CHANNEL NUMBERS (72) OR COLORS (RED)

T-Shirt Size: SM ___ MD ___ LG ___ XL ___ XX ___ 3X ___

Amount

enclosed: \$ _____

Mail check or money order to: SCORE, 1 Melinda Circle, Savannah, Georgia 31406

JG'S BOLT-ON ADVANTAGE

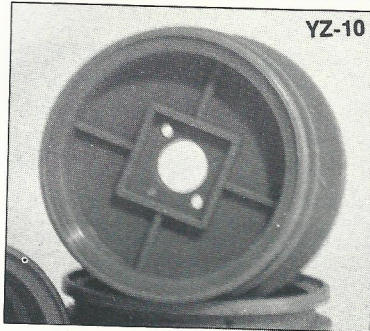

DIRECT BOLT-ON MONSTER TRUCK RIMS

These "new" dyable nylon rims are ultra lightweight for less unsprung weight. Front rims use stock bearings and axle nuts, rear rims use stock axle nuts. Both front and rear rims are ribbed across back for super strength.

- 1453 RC-10 Front Nylon Direct Bolt on Rims.
- 1454 RC-10 Rear Nylon Direct Bolt on Rims.
- 1455 Kyosho Front Nylon Direct Bolt on Rims.
- 1456 Kyosho Rear Nylon Direct Bolt on Rims.
- 1457 YZ-10 Front Nylon Direct Bolt on Rims.
- 1458 JRX2 Front Nylon Direct Bolt on Rims.
- 1459 JRX2 Rear Nylon Direct Bolt on Rims.

Set of Two: \$6.95

NEW! 4-COLOR PACKAGING FOR JG MONSTER TRUCK CONVERSION KITS.

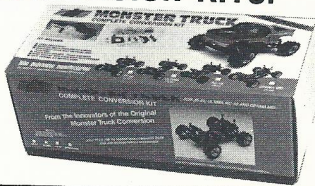

NEW 1990 CATALOG!

For the latest Monster Truck, On & Off Road conversions, tire parts and accessories send \$3.00 cash or money order.



John gudvangen manufacturing

P.O. Box 6014, Whittier, CA 90609-6014
(213) 947-1206 FAX: (213) 693-2577

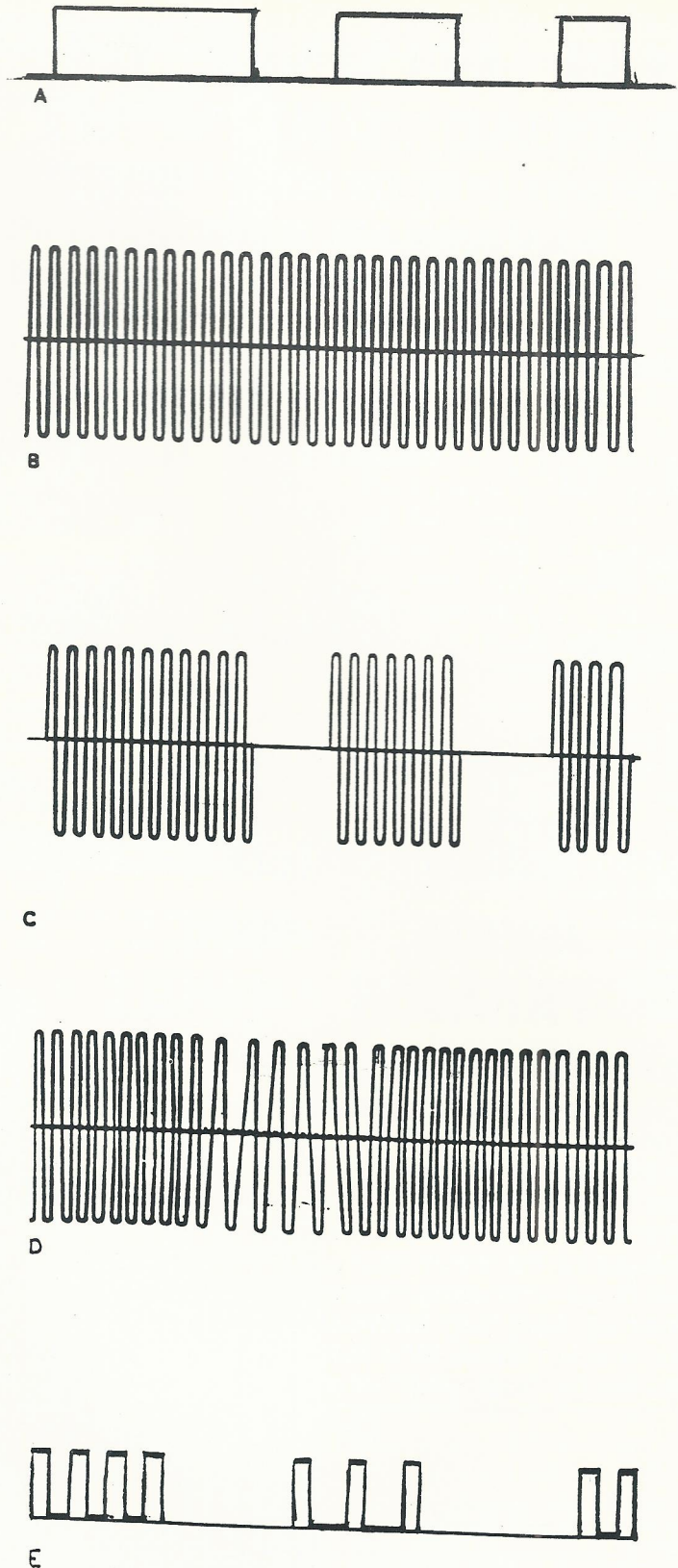

This is a simplified comparison chart of the different modes of signal transmission. A) Control Signal From Steering. B) Typical Carrier Signal. C) Modulated AM Steering Signal (Control and Carrier signal combined.) (Modulated). D) Modulated FM Steering Signal (Control and Carrier Signal Combined.) E) Demodulated PCM Binary Computer Mode.

steering wheel controls the direction a car will travel but the steering angle adjuster controls indicate how far you must turn the steering wheel to get full left or right steering from the servo in the car. Adjust the knob up to decrease the amount of steering travel required to get full

movement from the steering servo and adjust the knob down to increase the amount of steering wheel travel required to get full movement from the servo. To start with, set the steering angle adjustment in the middle. The THROTTLE ALT knob would be better defined as the brake adjustment knob. Changing the setting of the throttle alt, changes the amount of braking. Since full braking is needed with an electronic speed controller(ESC), set this knob to "10" otherwise, only a percentage of full braking will be done.

On the back of the two transmitters are two more controls worthy of mention, the THROTTLE NEUTRAL ADJUSTER and the STEERING D/R. The THROTTLE NEUTRAL ADJUSTER is used to set the actual amount of movement the trigger has for accelerating or braking. On "1/2" each direction gets equal travel. On "1/3" the accelerating portion gets twice as much travel as the brakes; this is

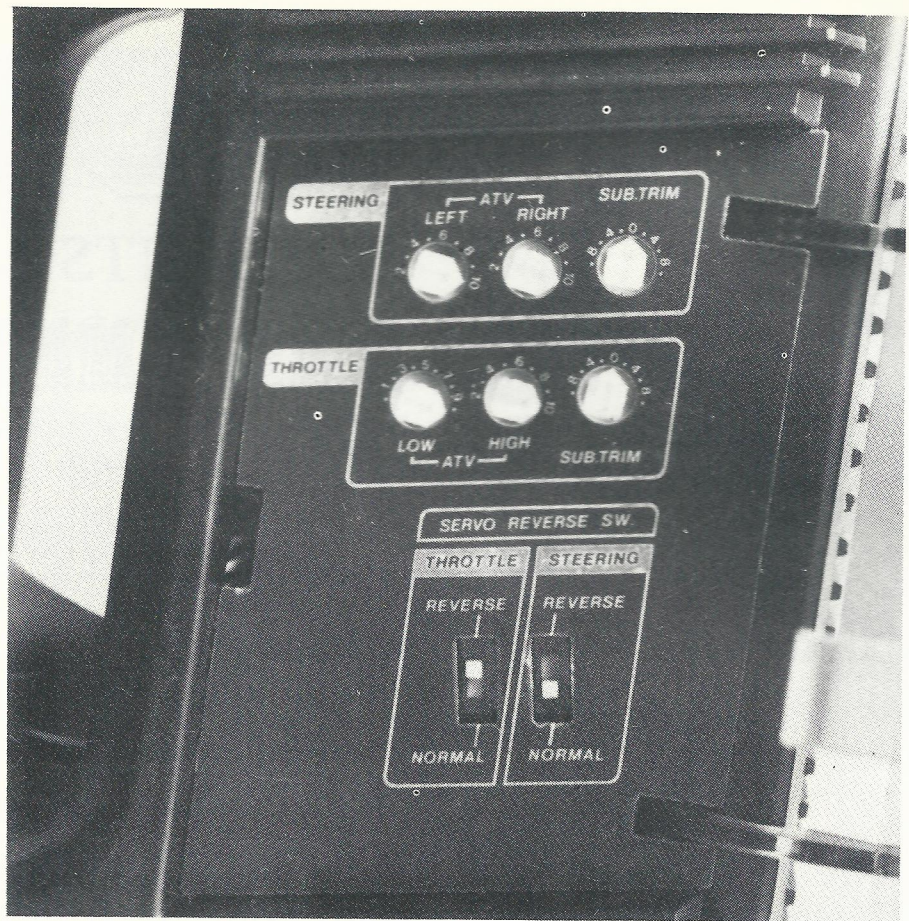

AMs Command Center. Note the settings.

A & D Racing Products

SANYO
BATTERIES

THE
POWER
SOURCE

NATIONAL CHAMPIONS
BREAKING TRACK RECORDS

1989 Roar 1/10 Dirt Oval
NATIONALS 1ST PLACE
Sammy Blackwell
used **A & D** Batteries
and won **BIG**.

A & D Racing Products has won **NATIONAL**, regional, and state championships throughout the U.S. and has qualified several racers to compete in upcoming IFMAR WORLD CHAMPIONSHIPS.

A & D Racing cells are especially conditioned and tested, then matched to the 3rd cycle on a specialized computer system.

A & D Batteries are not only matched on run time, but other characteristics as well, and every battery pack is matched to within 3 seconds before being shipped out. This ensures that every racer will get a truly matched battery pack.

A & D Pricing is very competitive and in most cases considerable lower than our competitors prices.

For more information: **A & D Racing Products**
Ph: **314-441-0773** **#12 Plaza 94 Suite 218**
St. Charles, Mo. 63303



CORCAR



PRESENTS

THE 3RD ANNUAL SUMMER MIDWEST 1/10TH OFF ROAD CHAMPIONSHIP

OVER 40 YR. CLASS 2WD STOCK (ID REQD.)
2WD & 4WD STOCK SAT JUNE 9, 1990

MONSTER TRUCKS OPEN
2WD & 4WD MODIFIED SUN JUNE 10, 1990

PREPAID ENTRY FEE \$30 WITH HANDOUT MOTOR, \$35 AT THE TRACK. PREPAID ENTRY FEE FOR MODIFIED AND MONSTER TRUCK \$25, \$30 AT THE TRACK. NO CALL IN ENTRIES PLEASE. DEADLINE FOR MAIL ENTRIES WILL BE MON. JUN 4, 1990. CONFIRMATION W/MAP AND HOTEL LIST WILL BE MAILED UPON RECEIPT OF ENTRY FEE / WITH LARGE SELF-ADDRESSED STAMPED ENVELOPE. SIGN-INS CLOSE AT 9:00 AM SAT JUNE 9 FOR STOCK AND 9:00 AM SUN JUNE 10 FOR MODIFIED. THREE QUALIFIERS AND A MAIN WILL BE RUN ON EACH DAY. TROPHIES: 1ST THRU 10TH ALL A-MAINS. 1ST THRU 3RD ALL OTHER MAINS. PLEASE LIST 3 FREQUENCIES FOR EACH CLASS ENTERED. FOR MORE INFORMATION CONTACT RAY WILLIAMS AT (614) 890-2983. NO PHONE CALLS AFTER 9:00 PM PLEASE.

NEW THIS YEAR AMB AUTO COUNT SYSTEM

NAME _____ ROAR NO _____

ADDRESS _____

CITY _____ STATE _____ ZIP _____

SKILL LEVEL: BEGINNER _____ INTERMEDIATE _____ EXPERT _____

2WD STOCK - FREQUENCIES 1. _____ 2. _____ 3. _____

OVER 40 2WD STOCK - FREQ 1. _____ 2. _____ 3. _____

4WD STOCK - FREQUENCIES 1. _____ 2. _____ 3. _____

2WD MODIFIED - FREQS 1. _____ 2. _____ 3. _____

4WD MODIFIED - FREQS 1. _____ 2. _____ 3. _____

MONSTER TRUCK - FREQS 1. _____ 2. _____ 3. _____

MAIL AND MAKE CHECK PAYABLE TO:

CORCAR

% RAY WILLIAMS

2145 PINE KNOLL

COLUMBUS, OHIO 43229

ENTRY FEE NON REFUNDABLE

SANC. NO.

LIMIT ENTRIES STOCK 175

MOD 150



ROAR
MEMBERSHIP
REQUIRED
(available at race)

MID CAROLINA RC SUPERSPEEDWAY

PROUDLY HOSTS

1-77/CAROWINDS EXIT
FLINT HILL RD
FORT MILL, SC



**SPACE
AGE
TECHNOLOGIES, INC.**

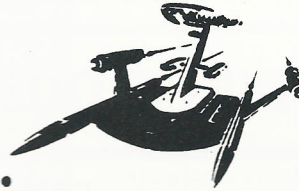

*****RACE OF CHAMPIONS***** **SAT TIRE DASH** JUNE 29-JULY 1, 1990

1/10TH SCALE STOCK CLASS

STOCK MOTOR SUPPLIED WITH ENTRY
EXTRA MOTORS AVAILABLE

6-CELL BATTERIES ONLY
(4) MIN RACES

MAX
ENTRIES
150 PER
CLASS

1/10TH MODIFIED CLASS

ROAR APPROVED MODIFIED
MOTORS ONLY

6-CELL BATTERIES ONLY
(4) MIN RACES

SAT TIRE DASH (OPEN TO ANY RACER REGISTERED IN ANY CLASS WITH THE
FOLLOWING REQUIREMENTS HAVING TO BE MET):

1. STOCK HANDOUT MOTORS TO USED ONLY (MODIFIED DRIVERS CAN
PURCHASE A HANDOUT IF THEY WANT TO RUN IN DASH)
2. 6-CELL BATTERIES ONLY
3. SPACE AGE TECHNOLOGIES TIRES WILL HAVE TO USED (TIRES WILL BE
AVAILABLE AT A SPECIAL PRICE FOR THIS RACE)
4. 1ST PLACE PRIZE VICTOR ENGINEERING HIGH I/Q CHARGING SYSTEM

FRIDAY: 8 AM TILL : OPEN PRACTICE

SATURDAY: 8 AM- 10 AM PRACTICE

10:30 AM START SAT RACE OF CHAMPIONS QUALIFYING
(3) ROUNDS OF QUALIFYING BEGINS

7 PM START SAT TIRE DASH

SUNDAY: 8 AM-9:30 AM PRACTICE

10 PM PARADE OF CARS

11:30 PM START SAT RACE OF CHAMPIONS MAIN EVENTS

TROPHY PRESENTATION AND PICTURE SESSION

TRACK CLOSED

TRACK: 385' CENTERLINE
AMB LAP COUNTING SYSTEM
WITH TRACKMATE RACE
MANAGEMENT SYSTEM
LIMITED POWER TO PITS

FOR ADDITIONAL INFO CALL :FRED PENLAND AT (803)328-8278

OR ROCK HILL HOBBIES AT (803) 366-4400

MAKE CHECKS PAYABLE TO :TGF PROMOTIONS, INC. MAIL ENTRIES FORMS AND CHECKS TO:
TGF PROMOTIONS, INC 2222 WINTERCREST DR ROCK HILL, SC 29732

NAME _____ PHONE _____

ADDRESS _____

CITY _____ ZIP _____

CLASS : 1/10 STOCK 1/10 MODIFIED SAT TIRE DASH

PRE-ENTRY FEE : BEFORE 6/22/90

\$40 STOCK W/HAND OUT MOTOR

\$30 MODIFIED

\$ 5 SAT TIRE DASH

LATE ENTRY FEE : AFTER 6/22/90 \$5 EXTRA

FREQ 1 _____

FREQ 2 _____

FREQ 3 _____

ENTRY FORM:

NO REFUNDS

HOST MOTEL:

BEST WESTERN MOTOR LODGE

1/77 CAROWINDS EXIT

(803) 548-8000

RATE YOURSELF AS A DRIVER: A _____ B _____ C _____ D _____

NEW • EXCLUSIVE • NEW • EXCLUSIVE

ULtra-Seals

frictionless
sealed bearings

Goodbye DIRT & DUST

Boca Bearing are Frictionless Sealed, Maintenance Free Race Bearings that virtually eliminate Dirt & Dust. They've been racer tested with tremendous results!!!

NOW AVAILABLE FOR RC10, TQ10, RC10/12L, JA-X2 ELIMINATOR 10/12, INVADER, PRO10 & OTHERS

BOCA BEARING ULTRA-Seals

Send \$3.00 for Bearing Guide and Further Information to:

7040 W. PALMETTO PARK ROAD, SUITE 2304, BOCA RATON, FLORIDA 33433

PHONE: (407)488-9606

NORTH AMERICA TOLL FREE

FAX: (407)488-9609

USA: 1-800-332-3256 / CANADA: 1-800-553-3256

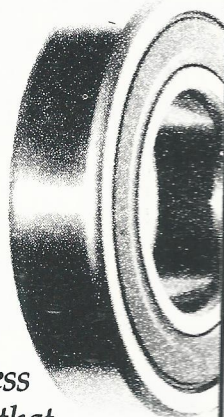

the setting I like, since I set my brakes for instant full when applied. The STEERING D/R is used to set the transmitter up for different turning radii for different tracks. I use this control in conjunction with the WHEEL ANGLE ADJUSTER to set my minimum turning radius at full turn of the steering wheel.

BEHIND THE

SMOKEY DOOR: AM

On the face of the AM transmitter is one more control, the THROTTLE TRIM. This control is used to set the neutral position of the speed controller and needs to be used in conjunction with the THROTTLE SUB-TRIM which is behind the panel door. The normal setting for both of these controls is "0" and the car should not move; if it does, re-adjust the neutral setting on the ESC. Set the throttle trim so that the car takes off with the slightest touch of the trigger. As you open the door on the main body of the transmitter there are

ESPRIT SERIES

Power Within Your Reach.

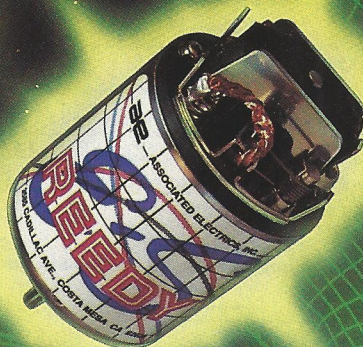

Introducing the **Esprit Series** motors. Based upon Yokomo's Esprit motor—which set **THE** world-wide standard for R/C car racing! Affordable power for everyone, the economical Esprit Series motors deliver reliable performance racers have come to expect from the name **Reedy Modifieds**.

Mike Reedy developed the individual winds. All motors were built to demanding specifications established through extensive testing in the same Reedy motor lab that bred 5 IFMAR World Champions.

The Sport models incorporate bushing-type bearings. The Ultimate models use ball bearings for extra life.

REEDY
Modifieds

TEAM ASSOCIATED

ASSOCIATED ELECTRICS, INC.
3585 CADILLAC AVE.
COSTA MESA, CA 92626
(714) 850-9342 TLX 756887
FAX 714-850-4744

RC10L TOPS 70MPH!

CLAUSEN CAUGHT SPEEDING IN CALIFORNIA

With factory ace Kent Clausen at the controls, an Associated RC10L ran through the traps at the Thunderdrome Oval at a record breaking 70MPH.



Fiberglass or Graphite chassis

THE RC10L
Team Associated's Newest Champion.

NiCd saddle pack, electronic speed control, body and radio not included.

The RC10L is a winner on the road, too, with Rick Hohwart taking the ROAR 1:10 Scale/Modified National Championship in Alabama.

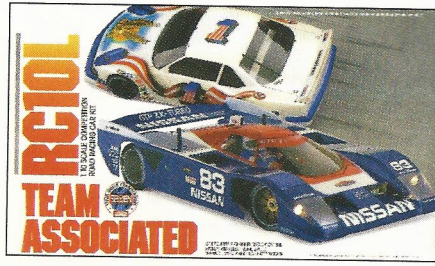

Complete ball bearing kit and graphite rear axle included.

A WINNING RACING HERITAGE

The RC10L has a tough act to follow, being first cousin to the 2-Time World Champion RC12L.

But the RC10L is designed to follow no one.

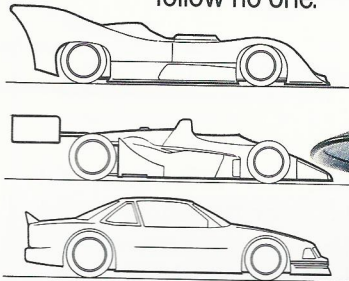

Pick a body, any body. Associated has Stock, Formula, Sports, and GTP bodies for the RC10L.

Strong, simple and easy to dial in, the RC10L is already rewriting the record books, indoors and out. Lay out a track and the RC10L wins on it. The RC10L's T-ball, monoshock rear and independent coil spring front suspension can be quickly tuned to all smooth racing surfaces.

Get an RC10L and start speeding, too.

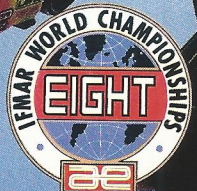
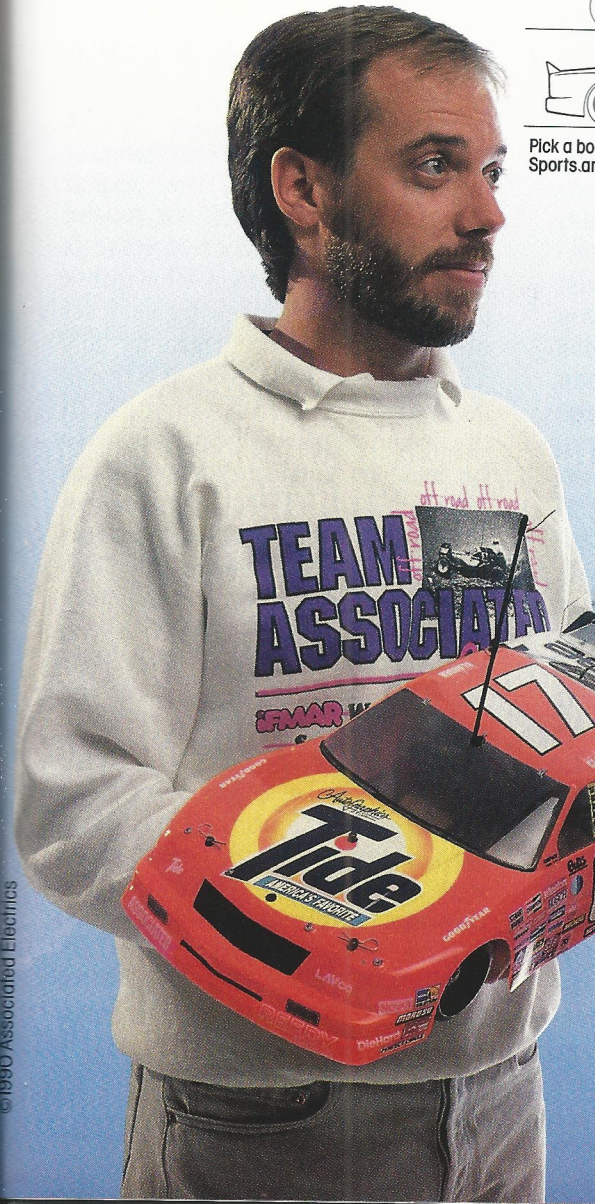

TEAM ASSOCIATED
3585 Cadillac Avenue
Costa Mesa, CA 92626

TEAM ASSOCIATED WOULD NEVER ADVOCATE NOR CONDONE THE ACTUAL EXCEEDING OF A POSTED SPEED LIMIT. HONEST. NEVER OPERATE A RADIO CONTROL CAR ON A PUBLIC STREET OR WHERE IT MAY CREATE A HAZARD TO MOTOR VEHICLES.

eight controls; four for throttle and four for steering. There are servo reversing switches for both throttle and steering. These switches control; the direction in which the servo responds when the steering wheel or throttle trigger is moved. Set these switches to the appropriate position for each of the controls. The STEERING ATV controls set the amount of steering travel required to get maximum steering from the car. Both of these controls should be kept symmetrical or both controls should be set to the same setting; set this control to "10", which will require full steering wheel travel to get full servo movement. Set the STEERING SUB-TRIM to "0". Use the steering trim control for adjustments. The THROTTLE ATV controls, provide fine tuning for throttle and brakes. I set mine to "10" and use the throttle trim and alt controls for setting up my driving controls. We've already discussed the throttle sub-trim.

BEHIND THE SMOKEY DOOR: PCM

Two of the controls on the PCM that are noticeably different are the THROTTLE TRIM and STEERING TRIM controls. These controls are now push button controls. They work the same, but they have been strategically placed so they can be altered while driving. The thumb can be used to change the THROTTLE TRIM and the forefinger of the right hand can be used to change the STEERING TRIM. To aid the THROTTLE TRIM, Futaba has provided an LED display just below the THROTTLE ALT control. Now let's open the panel door. Since the PCM is a three channel unit, there are three rows of trim controls and a bank of switches. The first row of controls are the STEERING ATV controls. These controls set the amount of steering travel required to get maximum steering from the car. Both of these controls should be kept symmetrical or both controls should be set to the same setting;

Are you planning a **BIG** event?

TRINITY
Speedworks

new wave technology

Hand out stock motors

If you are thinking about staging a major race, or simply need handout club motors, there is only one logical choice! The TRINITY™ and SPEEDWORKS™ stock motors are now available for your race.

Why settle for second best, when you can use the fastest most reliable motors on the market.

For pricing and more information just give us a call and ask for Tony P.

Trinity Products Inc. • 1901 E. Linden Ave.#8 • Linden, N.J. 07036
• (201) 862-1705 • Fax: (201) 862-6875

set this control to "10", which will require the steering wheel travel to get full servo movement. Set the STEERING SUB-TRIM to "0". Use the steering trim control for adjustments. The EXP controls select linear or exponential response to steering. A new control, the EXP, adds a new twist not available in the AM version, it controls the type of response the steering wheel gives when turned. If EXP is set to "0", the steering wheel and steering servo act linearly or in direct proportion to each other. If EXP is set to the left of "0", you get more steering from the servo in the early travel of the steering wheel and when EXP is set to the right of "0" you get more response from the end (full) of the steering wheel travel. I like a linear response so I set mine to "0". The next set of controls is the THROTTLE ATV controls. They provide fine tuning for throttle and brakes. I set mine to "10" and use the throttle trim and alt controls for setting up my driving controls. The EXP controls the type of response the trigger gives when depressed. If EXP is set to "0", the brakes and speed act in a

linear fashion or uniformly as the trigger is pushed. If EXP is set to the left of "0", you get more response proportionally in the early application of the trigger than at the end of the trigger travel. When EXP is set to the right of "0" the early response is less than at the end. I like quick acceleration and braking so, I set mine to "1" to the right of "0". The THROTTLE SUB-TRIM is used to set the neutral position of the speed controller and needs to be used in conjunction with the THROTTLE TRIM. The normal setting for both of these controls is "0" and the car should not move. Set the throttle trim such that the car takes off with the slightest touch of the trigger. The third set of controls, controls the third channel. Since there is no direct control for the third channel 1 or 2. In other words, as channel 1 or 2 performs a function, channel 3 performs its function. The MIX SET switch chooses which channel is to be mixed with channel 3. When MIX SET is in position 1 or "BRAKE" its mixed/controlled by channel 2. If your car has a brake servo then this is the set-

ting for you. Set the MIX LIMIT to the full right position and adjust the rate to suit your driving style. Position 2 or the BOAT setting will be skipped for this driving style. Position 2 or the BOAT setting will be skipped for this article. Position 3, 4WS (4 wheel steer), is used when four wheel steering is required. This setting ties channel 1 to channel 3 so that when the front steering servo is activated, the rear steering servo is also activated. Set the MIX LIMIT to "0" and adjust MIX RATE to suit driving style. Of course, none of these settings will work if the MIX switch isn't set to "ON". To center the channel 3 servo, use the AUX trimmer potentiometer.

The first switch on the switch block is the MIX switch which was discussed in the previous paragraph but the second switch is the PRESET SWITCH. The switch should be "ON" if 1/3 was selected on the THROTTLE NEUTRAL ADJUSTER (see THINGS IN COMMON) otherwise set it to "OFF". The PCM/PPM switch must be set to "PCM" to operate with the PCM receiver - FP R113IP. The last three switches on the switch block are the reversing switches for channels 1-3. These switches control the direction in which the servo responds when the steering wheel or throttle trigger is moved. Set these switches to the appropriate position for each of the controls.

One of the most misunderstood features of the PCM transmitter is the FAIL SAFE options. To set the FAIL SAFE ACTION, push the trigger to the desired position and push the FAIL SAFE SET button. Now, whatever trigger setting you set, when a fail safe condition is detected that set action will take place; i.e. if the trigger was set to brake, then when low voltage is detected or the receiver loses the transmitter signal the car will brake. If the FAIL SAFE switch is set to HOLD, the last action command received from the transmitter will be the action continued until the signal is regained. What all this means is: set the FAIL SAFE switch to F/S and set the FAIL SAFE SET to

DRESS FOR SUCCESS.

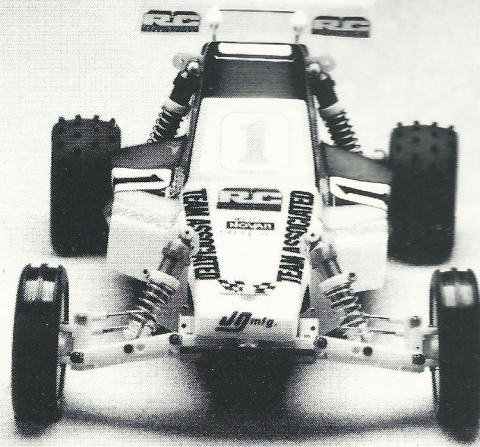

We've got the parts tailored to win. Like our race-developed Mirage SS body. Lightweight and aerodynamic, it's the latest in forward fashion. And it fits. Now the RC10, Ultima, JRX2 and TQ10 can look their best. Clear or custom painted by Greg's Graphics™ — we've got them. RC Performance Specialties. Call us for the parts that are serious about winning.

Wholesale Only
RC Performance Specialties
18312 Gifford St., Fountain Valley, CA 92708

TEL 714/962-6928
FAX 714/962-4089



brake, it'll buy time to regain control. If you are using a NiCd receiver battery pack, set the "Battery Fail Safe" to BAT F/S, BECs and regular batteries don't count, otherwise, the PCM will act just like a traditional transmitter and let the car go into a run-a-way condition. In summary, set the FAIL SAFE option to brake; the default setting of "HOLD" is trouble most of the time.

Another feature of PCM that's a radical departure from the norm is the DIRECT SERVO CONTROL (DSC). The feature allows you to test your car without turning the transmitter on. This is a great help for the mechanic in the pit making those last minute adjustments or repairs just prior to the next heat. The problem is, getting the transmitter out of the radio impound.

CONCLUSION

One of the things that made the old style Magnum so popular was its ability to be fine tuned; it

could be setup for a specific car, track or racing conditions. Futaba has increased this ability with the new Magnums. If you're in the market for new radio gear, check these units out.

'Til next time, GOOD RACING!!

Futaba
4 Studebaker
Irvine, CA 92718
(714) 455-9888.

■CP

SHOCKING NEWS

FIVE STAR is striking down the competition with it's **LIGHTNING QUICK** battery packs and chargers. Currently we are introducing a complete **new line** of products. Send **\$2.00** for catalog and receive **free** decal sheet to:

FIVE STAR
Five Star 3640 Milwaukee ST.
Port Huron MI. 49060
313-385-4550 Fax#313-385-4302

ALTERNATIVE RACING ASSOCIATION
HOSTS THE

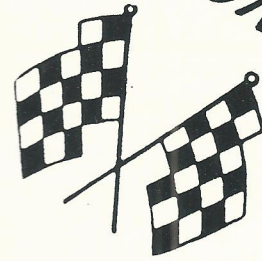
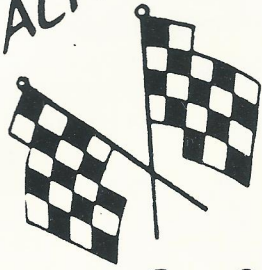

REGION THREE
6-CELL CHAMPIONSHIPS

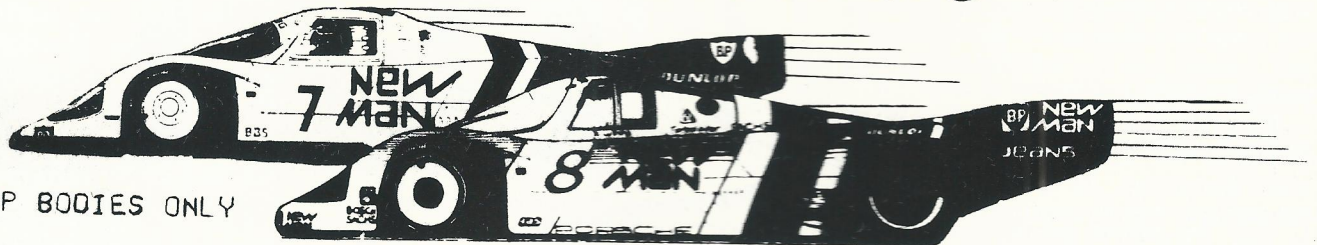

GTP BODIES ONLY

AUGUST 17, 18, 19, 1990
AT THE CANTON R/C SPEEDWAY
CANTON, OHIO



145 BY 65 FOOT ASPHALT ROAD COURSE
1/12 SCALE - 1/10 SCALE ON-ROAD



STOCK CLASSES \$35.00 INCLUDES ONE HANDOUT MOTOR. MODIFIED CLASSES \$30.00
BEST PAINT CONCOURS 1ST, 2ND, 3RD, PLACES

FOR ADDITIONAL INFORMATION:
CALL

NEAL EVERHART (216) 484-2587 OR DAVE MONEGAN (216) 233-0788

Send LARGE Self Addressed Stamped Envelope With Your Check To:
ALTERNATIVE RACING ASSOCIATION

3311 Shellburne
Canton, Ohio 44708



ROAR MEMBERSHIP REQUIRED !!!!
(Available At Race)
SANCTION # 39005

ADVANTAGE
MATCHED CELLS

TROPHIES: All A Mains, 1-3 All Others.

LIMIT ONE ENTRY TO EACH SCALE

1/12 SCALE: Stock _____, Modified _____ 1/10 SCALE: Stock _____, Modified _____

1/12th Frequency: 1. _____ 2. _____ 3. _____ 4. _____

1/10th Frequency: 1. _____ 2. _____ 3. _____ 4. _____

NAME _____ ROAR # _____

ADDRESS _____ PHONE # () _____

CITY, STATE, ZIP _____

REGISTRATION CLOSES JULY 31, 1990

TOTAL AMOUNT ENCLOSED _____



Mike Boylan won the Stock and Modified Open Class for a fantastic weekend! Also shown are Miss Lake Whippoorwill and Mike Reedy, both offering their congratulations!

(Continued from Page 62)

main, and so forth. This was done in the last heat only. It was almost like an A Main event. Another change was in the points. From first to fifth place it was the same as off-road, with first receiving one point, second receiving two points, etc. The change was implemented in the sixth through tenth position. Sixth through tenth all received the same amount of points as fifth place, five points. This was to keep racing alot closer. This system seems to be popular with off-roaders, however, with paved oval there were mixed reviews. Some drivers felt that this system did not determine the fastest driver, but the most consistent. They also felt that with oval racing the intent was to determine the fastest driver.

QUALIFYING

Qualifying for the non-invitational drivers was on Saturday. There were three rounds of Stock and three rounds of Modified and this event was sponsored by BoLink.

Stock qualifying got started

with Mike Kohler taking the TQ spot in round one with a time of 38 laps, 4:00.40. Mike Boylan was just a half second off that TQ pace. Your third qualifier was Jimmy Simmons with 38, 4:01.67. In all there were five drivers that went 38 laps in the first round. I felt that by the time qualifying finished the A Main would be

fulled with 38 lap runs and a few 39s. Mike Kohler made certain that if you were going to take the TQ away from him you would have to go 39 laps. Mike improved his TQ time by .45 of a second. It was the fastest time turned in round two.

In round three there were some fast runs turned in. The fastest being turned in by Joe Randow. Joe broke the 39 lap barrier and put himself in a league by himself. Joe's pole position time was a blistering 39 laps in 4:04.63. Mike Kohler moved down to a strong second and Mike Boylan was third qualifier. The A Main had one 39 lap run, seven 38 lap runs and two 37 lap runs.

With the Stock TQ going 39 laps, it was going to be interesting to see what the Modifieds would do. Phil Simms quickly told everybody what it was going to take to put your car on the pole in Modified. It was going to take 41 laps. Phil set the TQ time of 41 in 4:03.87. Ricky Jordan also went 41 laps with a time of 4:12.23 to put him in second.

Round two saw no 41 lap runs turned in. Ricky Jordan was the only driver to turn 40 laps. This, however, did him no good as he had already turned in a 41 lapper in round one.

Stop Paying Too Much For Batteries

Sanyo 1700 SCE Cells

up to 639 **\$3.50** each (6 min)

640-659 **\$4.75** each (6 min)

660-674 **\$6.00** each (6 min)

SCE 6 cell stick packs **\$24.95** each

TRACK RECORDS

Cooper's R/C, Callands, VA/Ray Turner (2-16-89)
Triangle Hobbies, Durham, NC/Dennis Fields (1-23-90)

Sanyo 1200 SCR Cells

Matched 6 cells 470+ packs **\$25** each

Matched 6 cells 480+ packs **\$32** each

Matched 6 cells 490+ packs **\$42** each

Minitech Tires & Wheels

Light Speed stock motors **\$22** each

"New" East Coast stock motors **\$22** each

B&T Racing Team We Accept Mastercard & Visa!
508 Lake Winds Trail ■ Rougemont, N.C. 27572

CALL 919-471-2060 12:00pm to 8:00pm E.S.T.

Round three again saw no 41 lap runs. Phil Simms ran fast in round one but had problems in his next two qualifiers, so he could not challenge his pole position time. Ricky Jordan and his BoLink ran strong in all three qualifiers, but could not topple his first round's best. Ricky would start next to Simms on the front row for the A Main. Ernie Bucci ran the fastest of the third round when he turned in a 40 lap 4:05.86 which gave him third on the grid. Going into the A Main Phil Simms was a whole eight seconds up on the field, but his consistency was the question.

STOCK A MAIN

Being on the front row for the Stock A Main was definitely not the place to start. At the start the two cars on the front row collided, causing a pile up at the start. Mike Boylan got the best start of them all from the second row, and put it in high gear. Unfortunately for the rest of the pack this was going to be their closest chance at being in front for the entire race. Ernie Bucci got out in second, followed by Jill Simms in third. By the first lap Boylan had opened up a 30 foot lead. Ernie Bucci was still in second, and Jill Simms was definitely a close third. Mike Boylan was not one to sit on his lead as he motored along with confidence stretching his lead with every rotation of his tires. When Bucci and Jill started to

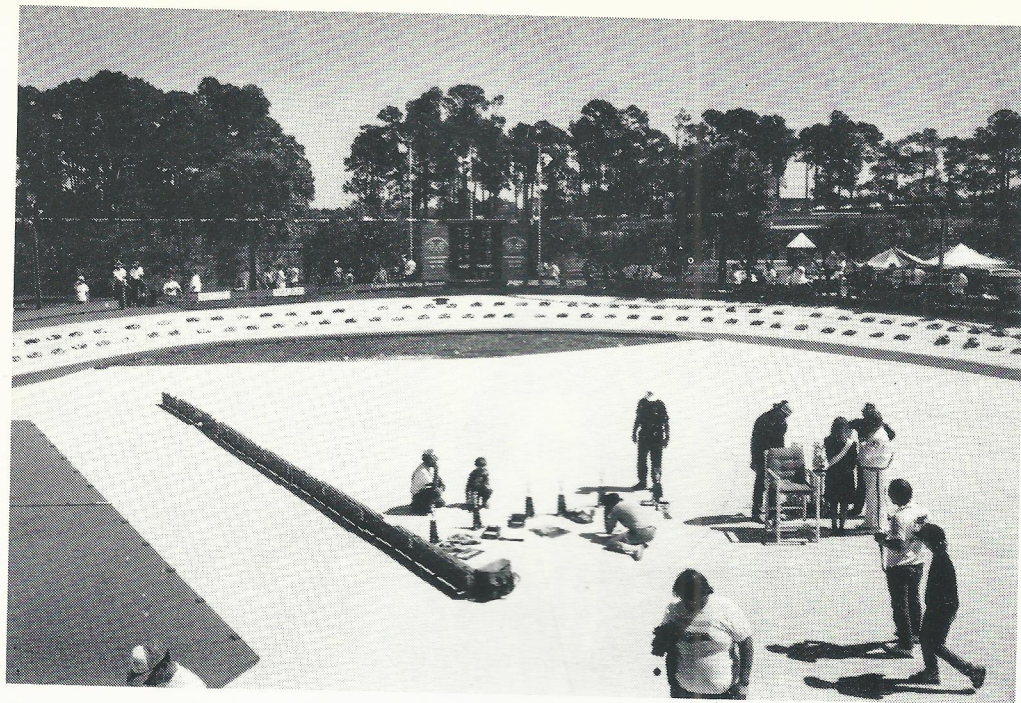

Parade of cars and an overview of the fabulous Lake Whippoorwill Speedway.

come up on traffic, Bucci seemed to have the upper hand. Through traffic Simms tied up with a slower car and moved back in the pack. Leroy Carrigg, now found himself in third place. By the half way point Boylan had a full lap on the field. Bucci who was still second had an unfortunate tangle with a lapper and flipped it. This allowed Carrigg to move to second. Bucci was not going to give up his second place. Bucci closed the gap and started to apply pressure. The two battled for awhile, then Bucci went by Carrigg. The race ended with Boyland first, Bucci second and Carrigg 1.5 seconds back in third. Applause should go out to Mike

Boylan for his fantastic performance. He not only won the race by two laps, but also turned in a time of 39, 4:02.96 which would have put him on the pole by two seconds. A real hats off performance by Boylan!

MODIFIED A MAIN

The start of the main saw Ricky Jordan get the hole shot followed closely by no other than Mike Boylan, the Stock class winner. In third spot was Ernie Bucci. Around for the first lap it was Jordan and his BoLink followed by Boylan with his Lynx. The two were separated by no more than ten feet. Bucci was just out of striking distance in third. Ricky and Mike were pushing each other hard, normally in this situation the third place car would close in on the lead battle but in this case the two of them were stretching their lead over Bucci. After the one minute mark the battle for the top spot was not getting any easier. Boylan was starting to get away and wanted to make a move for the lead. However, Boylan knew better than to push a move and take them both out. He just applied more pressure. This paid off for him at about the two minute mark when Ricky

Competition Batteries



KNOW WHAT YOU'RE BUYING!
STAGE III's test results are consistent & dependable.

WARNING!!!
"Home type" testers will often show readings of up to 25 pts. higher.
i.e. **STAGE III 675 = "Their" 700.**

SANYO® SCE's
STAGE III PROCESSED

STYLE	BEST FOR	STAGE III#	S/CELL
UNLIMITED	SUPER SPDWAY	675 +	14.25
SUPER MOD	ON ROAD, OVAL	660-74	12.50
SUPER STK	ON/OFF ROAD	635-59	7.00
ULTRA STK	OFF ROAD	620-34	4.50

**"KILLER" SCR's AVAILABLE*

COMPETITION BATTERY SALES
32588 Dequindre, Warren, MI 48092



313-588-2740
3:30 to 7:00 p.m. E.S.T.

was working his way through traffic and tied up with a backmarker and fell back. This gave Boylan the lead. Apparently after the crash Jordan's car never worked the same, as he could not make a charge back to the front and had to worry about retaining second from hard charging Dave Raber. At the 2:45 mark Raber was on Jordan and passed him for second place. Ricky Jordan started to regain his composure and moved his way back up to challenge Raber for second. The two were in a heated battle for the remainder of the race. Ricky got the upper hand and took second followed by Dave Raber in third. The real story of the weekend was Mike Boylan who won both Stock and Modified convincingly. I'm sure you will be looking for Boylan in the Invitational Class next year!

INVITATIONAL CLASS

With the numerous amount of races going on around the world these days it is a rare treat to have the two major motor manufacturers at the same location. Those being Mike Reedy of Reedy Modifieds and Ernie Provetto of Trinity motors.

After Friday's practice was over the fastest man for the Trinity Triad Team was Andy Dobson. Shawn Ireland was fastest for the Associated/Reedy Team.

Saturday was scheduled for four rounds of racing for the Invitational Class. Round one was dominated by Triad. Andy Dobson, Kim Davis and Paul Davis, all took wins. Round two saw Shawn Ireland and his Reedy powered 12L take a win followed by Chris Doseck with his horsepower provided by Cam and Buddy Bartos also being powered by Cam. With two rounds done the top three positions were first Shawn Ireland with three points; Andy Dobson second with four points; and Kent Clausen, Joel Johnson, Chris Doseck and Tim Lanier all tied with five points. Round three

saw Shawn Ireland tighten the reigns a bit as he took another win. Andy Dobson also took a win to keep him within one point of Ireland. Taking the third win in round three was Jim Fuller and his Triad package. The fourth and final round on Saturday saw the leader of the event, Shawn Ireland getting a DNF. Andy Dobson also took a DNF. Taking the wins in round four were Gil Losi, Jr., Bob Light and Paul Davis. At the end of four rounds with one throw out included it was Shawn Ireland with four points. Tied for second was Andy Dobson and Gil Losi, Jr. with five points. There was also a tie for third between Chris Doseck and Jurgen Lautenbach with six points. At this point it was still anyone's race. The fastest time at this point was turned in by Shawn Ireland with a 42, 4:06.45 run. Andy Dobson was just .4 of a second off that fast time.

Sunday came and there was still four rounds to decide your 1990 Reedy Race Champion. In round five the three winners were Kent Clausen, the Magic Man and Chris Doseck, with Ireland getting third in one heat and Dobson getting second in another, this put them tied for the lead with seven points. Losi, Jr. was DNF in the fifth round which put him back some points. With Doseck's win in this round he also had seven points to put him in a three-way tie for the lead.

Round six saw two back to back wins for two drivers. These two drivers were Joel Johnson and Kent Clausen. The third win went to Cliff Lett. Dobson got fifth in this round, which hopefully for him will be his throw out. Shawn Ireland got second in this round and Doseck took third.

At this point things started to get confusing as you have to start counting people's throw outs as there is only one more round to go. At this point I will not tell you where everyone stands and go on to the seventh round.

ALCRAFT



Home of R/C Raceway

Featuring the Best in
DIRT, CARPET, and HIGH
BANKED ASPHALT RACING

Super Sale Prices On Quality Equipment:

- Pyramid Power Supplies
- Competition Electronics Turbochargers
- Bud's Motor Analyzing Dyno
- Tekin Chargers
- Novak Speed Controls
- Futaba Radios & Components
- Car Kits: Associated, Kyosho, TRC, Composite Craft, BoLink, Lucas Agitators, Delta and Others

**SALE PRICES
AND
FREE UPS SHIPPING**

ALCRAFT

P. O. Box 297
1370 Custer-Orangeville Rd.
Brookfield, Ohio 44403

(216) 448-1573

VISA/MC

In round seven the three winners were Kent Clausen, who now won three in a row, Jim Fuller and Andy Dobson. At this point the top position was a three-way tie between Shawn, Andy and Kent. With all the throw outs officialy counted, they all had eight points. Second place was another tie between Joel and Chris Doseck with ten points. In the last round, as stated earlier, there was no throw out. The top ten people with the fewest points would be put altogether in one main. This is how it looked going into the eighth and last round:

- 1st - Ireland - 8 points
- 1st - Dobson - 8 points
- 1st - Clausen - 8 points
- 4th - Johnson - 10 points
- 4th - Doseck - 10 points
- 6th - Light - 11 points
- 6th - Losi - 11 points
- 8th - Lanier - 12 points

The World Famous
MEGATRAK
 SUPER SPEEDWAY

Presents The

parma



Region 1 Paved

Oval Championships
 JULY 7 & 8



Get ready for the race you've been waiting for. The 1990 ROAR Region 1 Paved Oval Championships. Drivers from everywhere will make their way to MEGATRAK and everyone will come out a winner. That's right, everyone. The reason is you won't find many races like this to attend. This high powered, electrifying weekend will send you home with your hair on end. This is it, the country's biggest region, ROAR Region 1, explodes with fury at MEGATRAK. Don't miss the ROAR Region 1 Paved Oval Championships sponsored by Parma International. Friday will be reserved for practice. Saturday there will be 3 rounds of qualifying and then on Sunday the main events. An information package will be sent to you upon receipt of your entry form and payment. ROAR rules will apply, ROAR membership required, memberships available at the track. Top qualifier trophies in each class "A" Main trophies 1st - 10th trophies, 1st - 3rd in all other mains.

Butch, "The Atomic Dragster" says "This race is bigger than my belly !!"

\$ 30.00 MODIFIED PER ENTRY
\$ 35.00 STOCK PER ENTRY *
 * This includes one hand out stock motor
 Entries will be limited - Sorry No Refunds

Make checks payable to Ed Angiuoli
 Mail entries to:
 MEGATRAK
 c/o Precious Cargo
 P.O. Box 815
 Browns Mills, NJ 08015

Track Information (609) 893-MEGA
 Travelling Directions (609) 893-7743
 MEGAFAX: (609) 893-0303

Call anytime for info, directions . If you have any questions MEGATRAK is located on Rt. 70, Mile Marker 31-32, Browns Mills, NJ (Bet. Rts 72 & 539)

Name _____ Phone # () _____

Address _____

CLASS	STOCK	MOD	FREQUENCIES		
1/10th Pan	<input type="checkbox"/>	<input type="checkbox"/>	1. _____	2. _____	3. _____
1/12th Pan	<input type="checkbox"/>	<input type="checkbox"/>	1. _____	2. _____	3. _____

ROAR Region 1

The World Famous **MEGATRAK** SUPER SPEEDWAY

Presents The

The 1990 New Jersey State Championships

Top Qualifier **Trophies** in each class
"A" Main **Trophies** 1st - 10th
Trophies 1st - 3rd in all other classes

July 22

**Future Events
Only at MEGATRAK**

CAM & Bud's
East Coast Oval Challenge
Aug 11 & 12
Reedy, Novak & Du-Mor
U.S. Paved Oval Championship
September

Once again, The 1990 New Jersey State Championships will be held at MEGATRAK on 7/22. It's no surprise it's held here, since last year's event brought competitors from 8 states and Canada just to be "New Jersey's Best". This event will be bigger and better than ever. This event will be all modified with 7 cell max. 1700 mAh max batteries. An information package will be sent to you upon receipt of your entry form and payment. This will include Hotel, Motel and other accommodations along with race schedule and format.



*Butch, The Atomic Dragster says
'Put up or shut up'*

**\$22.00 ENTRY FEE PER ENTRY
Sorry, No Refunds**

Make money orders
payable to Ed Angiuoli
Mail entries to:
MEGATRAK
c/o Precious Cargo
P.O. Box 815
Browns Mills, NJ 08015

**Track Information
(609) 893-MEGA
Travelling Directions
(609)893-7743
MEGAFAX:
(609) 893-0303**

Call anytime for info, directions . If you have any questions MEGATRAK is located on Rt. 70, Mile Marker 31-32, Browns Mills, NJ (Bet. Rts 72 & 539)

Name _____ Phone # () _____

Address _____

CLASS **FREQUENCIES**

1/10th Pan	1. _____	2. _____	3. _____
Gearbox Suspension	1. _____	2. _____	3. _____
Monster Trucks	1. _____	2. _____	3. _____

Don't Miss this fabulous day of racing !!!!!



BUYERS BEWARE

OF MISLEADING CLAIMS!

BEWARE of "silver plated" wire that contains no silver!

BEWARE of "13 gauge" wire that is actually 14 gauge!

BEWARE of solid connector bars that are claimed to be "superior" to braid!

IN FACT, only Stage III produces wire products specially designed to exceed R/C specs!

■ **ULTRABRAID** has the lowest load resistance of any shunt connector.

■ **SUPER 13** has the lowest resistance and highest strand count of any 13 gauge, 805!!

■ **DRAGIN** wire has the lowest resistance and highest strand count of any 12 gauge, 1660!

AND, ALL of our wire products are the purest possible copper, tin electro-plated for corrosion resistance and fast, easy soldering.

STAGE III (313) 585-1150

AVAILABLE AT ALL SERIOUS HOBBY SHOPS

9th - Lautenbach - 13 points

10th - Lett - 14 points

After seven rounds there was still a three-way tie for the lead. It would all come down to this last main event. Realistically, those three drivers were the only people to have a chance to win. In the last round Kent Clausen and his Associated/Reedy combination took third. Shawn Ireland and his Reedy powered 12L took second. The winner of the eighth round and winner of the 1990 Reedy Paved Oval Race of Champions was Team Trinity Triad's Andy Dobson. Dobson was fast all weekend long and truly deserved this hard fought victory.

This weekend was a very exciting and highly competitive weekend of super fantastic racing! Congratulations to all who came to compete! Thanks to the sponsors: Reedy Modifieds for the Invitational Class and Bo-Link for bringing us the "BoLink Clash."

If you are ever in Orlando, I would strongly recommend checking out the legendary Lake Whip-poorwill International Speedway, you won't be disappointed!

STOCK MAINS A MAIN

- 1st - Mike Boylan/10L
- 2nd - Ernie Bucci/Comp. Craft
- 3rd - Leroy Carrigg/Comp. Craft
- 4th - Craig Carey/Hyperdrive
- 5th - Mike Kohler/Comp. Craft
- 6th - Phil Simms/Lynx
- 7th - Jill Simms/Lynx
- 8th - Bill Kellum/Lynx II
- 9th - Joe Radow/Lynx
- 10th - Jimmy Simmons/TRC

B MAIN

- 1st - Chris McIlwain
- 2nd - David Carrigg
- 3rd - Mark Shirey
- 4th - George Smith
- 5th - Case Fessler
- 6th - John Jenkins
- 7th - John Jolley
- 8th - Wayne Croft
- 9th - Edmond Lacoste
- 10th - Dick Schafer

C MAIN

- 1st - Don Moncsko
- 2nd - Jerry Wynn
- 3rd - J. D. Crow
- 4th - Danny Monegan
- 5th - Keith Rockett
- 6th - Brad James
- 7th - Bob Posey
- 8th - Paul Messick
- 9th - Chuck Rencurrel
- 10th - Little John Walters

D MAIN

- 1st - Dave Monegan
- 2nd - Dennis Cutman
- 3rd - Robert, Jr. Highfill
- 4th - Stephen Miniea
- 5th - Darryl Reich
- 6th - Skippy Gibson
- 7th - Johnny Barlow
- 8th - Thomas Colclasure
- 9th - Jason Babb
- 10th - Sam Palazzolo

E MAIN

- 1st - Ken Hooper
- 2nd - David Neidhardt
- 3rd - Don Neidhardt
- 4th - Rick Waters
- 5th - Jeff Rey
- 6th - Shawn Rhoades
- 7th - Vince Bellino
- 8th - Jim Frahm
- 9th - Tom Ickes
- 10th - Bob Serra

F MAIN

- 1st - Mark Cosgrove
- 2nd - Dave Armstrong
- 3rd - Todd Sauve
- 4th - Bobby Layman
- 5th - Ricky Witt
- 6th - Billy Emenecker
- 7th - Armon Beckom
- 8th - Darren Gray
- 9th - Russell Upton
- 10th - Josh Moncsko

G MAIN

- 1st - Steve Rule
- 2nd - Craig Stiwald
- 3rd - Paul Elliott
- 4th - Tony Jolley

- 5th - Greg Spehn
- 6th - Mike Cohen
- 7th - Mark Gregory
- 8th - Dennis Vansant
- 9th - Randy Wheeler
- 10th - Robert Joyce

H MAIN

- 1st - Dan Toll
- 2nd - Jeff Flassig
- 3rd - Tony Carrubba
- 4th - Richard Price
- 5th - Brian Wood
- 6th - Steve Clark
- 7th - Richard, Sr. Kastner
- 8th - John, Jr. Leslie
- 9th - Rick Rockafellow
- 10th - David Martin

I MAIN

- 1st - Ed Clement
- 2nd - Tim Snider
- 3rd - Rich Dettinger
- 4th - Jerry Kikkert
- 5th - Robert Kniprath
- 6th - Tim Breedlove
- 7th - Chad Mears
- 8th - Chris Littrell
- 9th - Alan Inman
- 10th - Joe Zglinicki

J MAIN

- 1st - Jeffrey Stowe
- 2nd - Kevin Vermillion
- 3rd - Todd Braun
- 4th - Morris Kohl
- 5th - Matt Blazo
- 6th - Russell Mills
- 7th - John Kruase
- 8th - Tom Tilton
- 9th - Charles Niemann
- 10th - John Kunstbeck

K MAIN

- 1st - Rob Press
- 2nd - Roland Gass
- 3rd - Micah Thigpen
- 4th - Mel Levine
- 5th - Doug Satterfield
- 6th - Leo Bechard
- 7th - Eric Colee
- 8th - Jason Jacques
- 9th - Steve Vazquez
- 10th - Steve Redmond

L MAIN

- 1st - Charles Wade
- 2nd - Lee Dodgen
- 3rd - Christopher Wardell
- 4th - Joe Pitts
- 5th - Richard Carpenter
- 6th - Dan G. Smith
- 7th - Stephen Salley
- 8th - Lonnie Warren
- 9th - Travis Chambers
- 10th - Greg Titus

M MAIN

- 1st - Leonard Southard
- 2nd - Keith Urbanski
- 3rd - Diane Rivers
- 4th - Mike Luby
- 5th - Russ Thrift
- 6th - Brent Tetreault
- 7th - Ronnie Vines
- 8th - Michael Cottle
- 9th - Miles Nelson
- 10th - Michael Ray

N MAIN

- 1st - Chuck Rayburn
- 2nd - Terry Coon
- 3rd - Chris Rock
- 4th - John Leslie
- 5th - Robert Schoeneman
- 6th - Jeff Clark

NORRCA

NATIONAL ORGANIZATION FOR RACING RADIO CONTROL AUTOS

1990 PAVEMENT ROAD COURSE NATIONALS

JUNE 1ST - 3RD BAKERSFIELD, CA

HOSTED BY RACERS HAVEN

- * NORRCA MEMBERSHIP IS REQUIRED * (MEMBERSHIP IS AVAILABLE AT TRACK OR THROUGH NORRCA)
- * NORRCA RULES APPLY * NORRCA OFFICIALS WILL BE PRESENT * SHIRTS FOR ALL ENTRANTS
- * NORRCA T.Q. PINS & TROPHIES FOR TOP QUALIFIER IN EACH CLASS * TROPHIES 1st -10th IN ALL "A" MAINS
- * 1-3 ALL MAINS * CONCOURS TROPHIES 1st - 3rd * TROPHY DASH FOR EACH CLASS * HOST HOTEL IS THE "PLAZA INN" 805-???-???? ASK FOR THE NORRCA RACE RATE * AIRPORT AND RESTAURANTS NEARBY * OVER-NITE PARKING O.K. * TOP QUALITY SMOOTH ASPHALT * GTP BODIES ALL CLASSES
- * 1ST ANNUAL NORRCA TEAM CUP CHALLENGE - THE TEAM WITH THE HIGHEST OVERALL POINTS WILL BE AWARDED A GOLD CUP FOR "THE BEST PAVEMENT ROAD COURSE TEAM" OF 1990 * TEAMS CANNOT COMPETE IN STOCK CLASSES * A MINIMUM OF 3 TEAM MEMBERS ARE REQUIRED IN EACH CLASS * ENTRIES DAY OF RACE IF AVAILABLE \$50.00 * STOCK MOTORS WILL BE SUPPLIED * SCHEDULE: MAY 31ST OPEN PRACTICE ALL CLASSES * 1ST 6:00 - 10:00 AM PRACTICE 10:30 AM-8:30 PM 3 QUALIFIERS * 2ND 8:30 AM CONCOURS 9:00 AM- 5:00 PM 2 QUALIFIERS * 3RD 8:30 TROPHY DASH, 9:00 AM MAINS * ALL SCHEDULED TIMES ARE APPROXIMATE. SCHEDULE MAY VARY AND CAN BE ADJUSTED AT ANYTIME

REVTECH



PURE-TECH
RACING PRODUCTS

MAXMOD
mini sports

COMPETITION
PLUS THE R/C CAR MAGAZINE

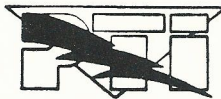

SCAT
RACING PRODUCTS

ADVANCED
RACING TECHNOLOGIES

B&R
MotorWorks

BUD'S
RACING PRODUCTS

Team
TRCIII

TSUNAMI
R/C PRODUCTS

NORRCA OFFICIAL 1990 PAVEMENT ROAD NATIONALS ENTRY FORM

NAME _____ PHONE _____
ADDRESS _____

CLASS(ES): DD STOCK _____ DD OPEN _____ GC STOCK _____ SPORTSMAN _____
SHIRT SIZE XX _____ XL _____ LG _____ MED _____ SML _____
EXPERT _____ 1/12 OPEN _____

FREQUENCIES 1. _____ 2. _____ 3. _____ SPONSOR(S) _____
FREQUENCIES 1. _____ 2. _____ 3. _____ CAR _____ MOTOR _____ RADIO _____

ENTRY FEE: \$35.00 1ST CLASS., \$25 EA ADD'L CLASS. STOCK CLASS \$40.00 (INCLUDES 1 MOTOR) NO ENTRY REFUNDS. SEND ENTRY & CHECK PAYABLE TO: NORRCA, 1530 W. 8TH ST #117, UPLAND, CA 91786 FOR ADD'L INFO. CALL TRACK 805-835-0441 OR NORRCA AT 714-981-9641. RACERS HAVEN 7401 WHITE LANE, BAKERSFIELD, CA 93309

NORRCA # _____

AUTOSCORE

The ultimate race scoring and race management program

- Menu driver - user friendly
- Quickly resolves frequency and number conflicts
- Sets up heats and mains in minutes
- Scores all qualifiers and mains by racer's name
- Will score up to 10 qualifiers and 1 main for each racer
- Can handle up to 1000 racers in 30 classes
- Prints complete standings by name or position
- Positions, lap times and speeds continuously displayed
- Runs on IBM pc or Compatable
- Only \$250, PRO version \$450
- Can be used with the AMB scoring system
- 1/4 scale version also available

Used by
R/C SPEED WEEK
NORRCA
R/C THUNDERDROME
AND MANY MORE

Send for FREE demonstration disk
(Include \$1.00 for shipping & handling)

B & B Software - 2146 Palomar Ave
Ventura, Ca 93001 (805) 643-2042

- 7th - Chris Crowder
- 8th - Sam Clark
- 9th - Tony O'Tyson
- 10th - Chet Ellis

O MAIN

- 1st - Doug Bancroft
- 2nd - Jack Baker
- 3rd - Bob Fairbrother
- 4th - Carey Kline
- 5th - Michael Rosenberger
- 6th - Jeff Rivers
- 7th - Jimmy Southard
- 8th - Tim Weaver
- 9th - Joey Staples
- 10th - Bill Evans

P MAIN

- 1st - David Harris
- 2nd - Scott Sokolowski
- 3rd - Bryan Flowers
- 4th - Mike White
- 5th - Brian Fowler
- 6th - Shaun McDuffie
- 7th - Mark Morse
- 8th - Ronald Moorehead
- 9th - Trevor Corbett
- 10th - Albert Sosa

Q MAIN

- 1st - Mike Ivanics
- 2nd - Michael Nelson
- 3rd - Richard Jr., Kastner
- 4th - Jeff Shupe
- 5th - Scott Schalk
- 6th - Adam Devaney
- 7th - George Olmo
- 8th - Herbert Consolvo
- 9th - Steve Platt
- 10th - Bob Waters

R MAIN

- 1st - Jimbo Bird
- 2nd - Wilton Adams
- 3rd - Ronnie, Jr. Hames

- 4th - Al Bouchard
- 5th - Dawn Delp
- 6th - Brian Vines
- 7th - Dan Norton
- 8th - Mike Breland
- 9th - Craig Markle
- 10th - Brent Braun

S MAIN

- 1st - Jerry Alford
- 2nd - Phil Farabough
- 3rd - Mike Leslie
- 4th - Frank Smith
- 5th - Barry Schroerlucke
- 6th - Chad Beal
- 7th - Sean Wager
- 8th - Drew Waters
- 9th - Timothy Daugherty
- 10th - Jeff Antle

T MAIN

- 1st - Vince Tate
- 2nd - Gret Fairbrother
- 3rd - Randy Collier
- 4th - Mathew Frye
- 5th - Graig Guido
- 6th - Randy States
- 7th - Jon Hill
- 8th - Randy Rawlings
- 9th - Joseph Sangimino
- 10th - Charles Long

MODIFIED MAINS

A MAIN

- 1st - Mike Boylan/Lynx II
- 2nd - Ricky Jordan/BoLink
- 3rd - Dave Raber/Associated
- 4th - Rob Cutman/Lynx II
- 5th - Phil Simms/Lynx
- 6th - Steve Rule/BoLink
- 7th - Kevin Lanier/BoLink
- 8th - Ernie Bucci/ Comp. Craft
- 9th - Case Fessler/Comp. Craft
- 10th - Paul Wynn/Scratch built

B MAIN

- 1st - Jeff Irish
- 2nd - Chris Smith
- 3rd - Mike Kohler
- 4th - Craig Markle
- 5th - Jill Simms
- 6th - Mike Mitzel
- 7th - Jan Limpach
- 8th - Mike, Jr. McBride
- 9th - Tyler Clements
- 10th - Craig Carey

C MAIN

- 1st - Gary Demory
- 2nd - David Davis
- 3rd - Jimmy Simmons
- 4th - Hoyt Stacey
- 5th - Jeff Rey
- 6th - Tony Carrigg
- 7th - Nick Themelis
- 8th - Ron Benash
- 9th - Damien Hallmark
- 10th - Andy Jacobson

D MAIN

- 1st - Bruce Triplett
- 2nd - Steve Swindle
- 3rd - James Cookie Prince
- 4th - Troy Schafer
- 5th - George David
- 6th - Vernon Harvell
- 7th - Tom Ahles
- 8th - Dave Monegan
- 9th - Lee Dodgen
- 10th - Greg Wilczewski

E MAIN

- 1st - Steve Wallace
- 2nd - Steven Maslin
- 3rd - Rob Press
- 4th - Stephen Miniea
- 5th - Darryl Reich
- 6th - John Jenkins
- 7th - Jim Shea
- 8th - Carey Slavin

- 9th - Steve Dunn
- 10th - Chuck Rayburn

F MAIN

- 1st - Brent Braun
- 2nd - Kevin Orton
- 3rd - John Nemcovic
- 4th - Rick Waters
- 5th - Keith Manton
- 6th - Barry Spinner
- 7th - Tim Helpard
- 8th - Little John Walters
- 9th - Joe Goodwin
- 10th - Paul Kelley

G MAIN

- 1st - David Vera
- 2nd - Jerry Kikkert
- 3rd - Tom Crowe
- 4th - Michael Bush
- 5th - Nicholas Schons
- 6th - Herk Strumpf
- 7th - Don Monesco
- 8th - Ed Clement
- 9th - Joseph McAdam
- 10th - Tom Ickes

H MAIN

- 1st - Jim Ryckman
- 2nd - Drew Wikander
- 3rd - Dave Vince
- 4th - Edward Weaver
- 5th - Mike White
- 6th - Frank Pupello
- 7th - Gordon Zito
- 8th - Daren Westman
- 9th - Greg Spehn
- 10th - Leo Bechard

I MAIN

- 1st - Wayne, Jr. Gerber
- 2nd - Bobby Trinchitella
- 3rd - Roland Gass
- 4th - Mark Harnish
- 5th - Brian Fowler
- 6th - Joey Staples
- 7th - Bill Frame
- 8th - Bill Evans
- 9th - John Mitchell
- 10th - Keith Rockett

J MAIN

- 1st - Todd Braun
- 2nd - Bruce Bunch
- 3rd - William Rumpfelt
- 4th - Rick Pruitt
- 5th - Joe Higgins
- 6th - Ernie Smith
- 7th - Fred Scadron
- 8th - Joseph Sangimino
- 9th - Mike Reedy
- 10th - Randy Annis

INVITATIONAL MAINS

A MAIN

- 1st - Andy Dobson/Lynx
- 2nd - Shawn Ireland/Assoc.
- 3rd - Kent Clausen/RC10L
- 4th - Gil, Jr. Losi/Comp. Craft
- 5th - Chris Doseck/Cam
- 6th - Jurgen Lautenbach/Comp. Craft
- 7th - Tim Lanier/BoLink
- 8th - Cliff Lett/RC10L
- 9th - Joel Johnson/Comp. Craft
- 10th - Bob Light/Comp. Craft

B MAIN

- 1st - Jim Fuller
- 2nd - Paul Davis
- 3rd - Bud Bartos
- 4th - Tony Neisinger
- 5th - Kim Davis
- 6th - Stephen Oberle
- 7th - David Timmerman
- 8th - Craig Kelley

C MAIN

- 1st - Tem Raskin
- 2nd - Art Carbonell
- 3rd - Orlando Milian
- 4th - Bob Sumner
- 5th - Bill Horne
- 6th - Rick Jordan
- 7th - Ken Buzzard

— Racing Schedule —

— 1/8 & 1/4 Scale —

OUTLAW MOTOR SPEEDWAY

Every first & third Saturday - 1/4 Scale
Dirt Oval. 7920 Webster, Highland, CA.
Call (714) 864-1770

THE RANCH PIT SHOP

1655 E. Mission Blvd., Pomona, CA
91766, (714) 623-1506. Every second
Sunday.

MACHESNEY PARK RACEWAY

1/4 Scale - Large asphalt Oval racing
every Saturday and alternating Sundays
April thru October. 1220 Shappert Dr.,
Machesney Park, IL 61111, (815) 282-
1311.

CAJON R/C SPEEDWAY

1875 Joe Crosson, El Cajon, CA 92020.
(San Diego County) - Asphalt Oval/
Road - Dirt Off-Road. Race Schedule
Hot Line (619) 449-0788; Track Info (619)
449-9948; 1/12, 1/10, 1/8, 1/4 Scale Rac-
ing. Monthly schedule available at track.
Race Every Sunday, Tues. nite, Friday
nite.

HOBBY CORNER RACEWAY

Large indoor dirt oval track - racing year
'round - 1/8 scale racing Wednesday
evenings - 1/8 and 1/4 scale racing Satur-
days. 2195 E. Garfield, Decatur. IL
62526. (217) 429-4477.

TARCAR-TOLEDO AREA

New black clay tri-oval. 1/18 gas stock
cars. Sundays late April thru mid-
October. For more info call Dave
Scanes, (419) 893-1916.

SMR/CRC

First Sunday of Each Month at G.I.A.
1660 Stewart Street, Santa Monica, CA.
Sign-up 8:30 a.m., Practice 9:15 a.m.,
Qualifying 10 a.m. For more information
call Glenn Williams (213) 734-7888,
Chris Chan (213) 393-3735, Tom Wong
(213) 821-5472.

— 1/10 Scale —

G & S OFF-ROAD RACEWAY

Every Sunday - San Carlos & Meridian
Avenue, San Jose, CA.

KANSAS R/C RACING CLUB

Every 2nd Sun. - Junction City - 1 p.m.
Every 4th Sun. - Enterprise - 1 p.m.

CENTRAL NEW YORK

Lawrence Race Park

2509 Macedon Center Road, Palmyra,
NY 14522. (315) 597-6429. 1/10 and 1/12
electric auto racing. Nov.-Mar. Carpet
racing 1/12 scale. Oval and road racing.
April-Oct.

REECE'S R/C RACERS

1st & 3rd Sundays at Spinner's Airport
Raceway, 2nd & 4th Saturdays at Reece's
R/C Racers. (209) 784-0922.

PANTHORN RACEWAY

Panthorn Park, Burritt St., Southington,
CT. Every Saturday May 1st to Nov. 1st.
Off-Road, Oval, Baja, Truck Pulling.



CELL REMATCHING

\$1.00 A CELL

VOLT & TIME USING

LAVCO 10 or 20 AMP

COMPUTER EQUIPMENT

Cleaning Available at 50¢ a Cell

Plus Shipping

FIVE FORKS VILLAGE - KING, NC 27021

919-983-3969 1-800-448-4712

Call (203) 628-9345 Ben Carr, 272-9326
Pete Church, 237-6976 Bob Lavoie, 879-
2316 Steve Magnani.

R/C HOBBIES RACEWAY

Route 163 Bozrah, CT

Racing Every Sunday - May 1 to Oct. 30.
For more information call: R/C Hob-
bies, (203) 886-9441, ask for Mike or Bob.

R & R HOBBY

We have 1/10 scale dirt tracks both
inside and outside, also 1/12 tracks both
inside, also 1/12 tracks both inside and
outside. R & R Hobby - 1414 N. 24th St.,
Quincy, IL 62301, (217) 228-1133.

HAL'S HOBBY SHOP

Every Saturday from 9:30 a.m. to 4 p.m.
Practice: Track open all week. Hal's
Hobby Shop, 4886-A Hercules, El Paso,
TX 79904, (915) 755-1914.

RIVER CITY R/C OFF-ROAD

Racing is every Saturday, sign-ups 3
p.m., racing starts at 3:30 p.m. (512) 656-
5724 evenings.

MASON DIXON R/C CAR CLUB

Every Sunday at 1:00 p.m. Track location
at Hagerstown Fairgrounds, Hagers-
town, Maryland. Call King's R/C Cars,
219 E. Washington St., Hagerstown, MD
21740, (303) 739-0080.

SNORR

Racing every 1st and 3rd Sundays. P.O.
Box 438, East Haven, CT, (203) 469-2594
or (203) 481-5813, Dave Seales.

TEAM RACE R/C CAR CLUB

Fridays: 6:30 p.m. 1/10 scale 505 Spring
Ridge, Clinton, MS 39056. Call (601)
924-0722.

F/X CITY RACEWAY

Every Saturday 1 p.m. The Frame
Gallery, 13340 F. Franklyn Farm Road,
Herndon, VA 22071. For info call Eric
Zelman, (703) 471-4499.

RIVER CITY RACEWAY

On Quincy Road, Wichita Falls, Texas.
Every 2nd & 4th Sundays at noon. Call
(817) 691-1478.

WALT'S HOBBY & CRAFT

2 Dwight Park Dr., Syracuse, NY 13209,
(315) 453-2291. New 12,000 sq. ft. bldg.
Two indoor tracks. 1/10 Clay Oval, Mon.
6:30 p.m. & Sat. 12 Noon; 1/10 Gearbox
Carpet, Mon. 6:30 p.m.; 1/12 & 1/10 Car-
pet Cars, Tues. 6:30 p.m. Oval and Road
Course; Wed. Evenings Weight Pulling.
Daily Practice. Computerized scoring.

HITT'S HOBBY AND RACEWAY

Tuesdays: Oval Asa, Full Bodies
Thursdays: Off-Road - Stock
Saturdays: Off-Road - Novice
Sundays: Off-Road - Modified
Oval and Off-Road; 853 Wren Rd.,
Goodlettsville, TN 37072. For info call
Ben or Kent (615) 859-3465.

CARCLUB - COCHRANTON AREA

The Carclub races Fridays starting at 6
p.m., Saturdays starting 9 a.m. Sundays
starting at noon. Large indoor carpet -
dirt outdoor. Call for info Harry Turner,
120 W. Adams St., Cochranton, PA
16314. (814) 425-7788.

QUEEN CITY R/C RACEWAY

1/12, 1/8 and 1/10 scale cars. Every
Friday - 7 p.m. -Open Class Every at -2
p.m. Stock & Open. Every Sun. - 2 p.m.
Drag Racing 5050 S. Federal Blvd.,
Englewood, CO 80110, (303) 730-1391.

PDQ RACEWAYS & HOBBIES

1/8, 1/10, 1/12 Scales

Call times and details. 429 Bankhead
Highway, Mableton, GA 30059, (404)
941-2626.

SROKA'S INDOOR R/C

Racing every Sunday - Oval racing every
4th Sunday. 5216B Arboga Rd., Marys-



10th SCALE

10th SCALE

2 WD Modified & 4 WD Modified - July 19th - 22nd

2 WD Stock & 4 WD Stock - July 26th - 29th

Limited to 350 Entries Per Weekend ** ROAR Rules Apply ** ROAR Membership Available At Raceway

CLASSES: 2 WD Modified 4 WD Modified 2 WD Stock 4 WD Stock
Limited To 2 Classes Per Entry

Stock Classes Will Use "hand-out" Motors

Hobby Haven Will Confirm Your Registration By Mail As Soon As Possible After Receipt Of Application
Entries Limited To The First 350 Applications Received For Each Weekend

Mail This Entry Form Or A Copy, Along With Your Check Or Money Order Payable To:

HOBBY HAVEN RACEWAY
72 South N Street
Livermore, CA 94550

FOR ADDITIONAL INFORMATION CALL:
Tom Welding Jr. - 415/443-5828

ENTRY FORM

NAME _____

ROAR Membership Number _____

ADDRESS _____

CITY _____

CAR _____ MOTOR _____

STATE _____ ZIP CODE _____

RADIO _____ SPONSOR _____

TELEPHONE NUMBER _____

SKILL LEVEL Novice Intermediate Expert

CIRCLE CLASS(ES) 2 WD Stock
2 WD Modified
4 WD Stock
4 WD Modified

CHOICE OF FREQUENCIES 1st ____ 2nd ____ 3rd ____
1st ____ 2nd ____ 3rd ____
1st ____ 2nd ____ 3rd ____
1st ____ 2nd ____ 3rd ____

ENTRY FEE:
\$45.00 Each Stock Class - \$35.00 Each Modified Class (No Refunds) TOTAL ENCLOSED \$ _____

T-Shirt Given To Each Driver -Your Size Preference (Please Circle One) S M L XL XXL

ville, CA 95901. Call Michael or Vickie Sroka (916) 742-6148 or (916) 741-3051.

FLINT R/C CAR CLUB

Flint, MI. Summer: Every other Sun. from May to Sept., Fall & Winter 1/12 4 cell on carpet. For info: Ralph Herndon (313) 658-5390 or Tom Hoos (313) 658-1043.

MILE-HI R/C SPEEDWAYS

Thurs. & Sat. Off-Road, Fri. Carpet, Sunday 2 p.m. 178 S. Kalamath, Denver, CO 80221, (303) 722-6766.

AMERICAN HOBBIES

Thursday Night Oval Racing
Sunday Off-Road & Oval
For info call (201) 446-2010.

C.A.R. CLUB

Racing at Tamarack Raceways. Contact Harry Turner, 120 W. Admans St., Cochran, PA 16314, (814) 524-7788. Racing every Sunday.

ARROW HOBBIES

Wed. Nights - 1/10; Every other Fri. night 1/8 Sprint Cars only; Sat. nights 1/10 dirt oval. 2710 So. 1-35 West, Burleson, TX (817) 295-2821.

BLASTERS OFF-ROAD CLUB

Dirt Oval and Circuit Off-Road Course. 47 Riel Dr., St. Albert, Alberta. Contacts Dean M. Simpson, (403) 481-8634, 17319 69th Ave., Edmonton, Alberta, Canada T5T 3S7.

BUCKLEY SPEEDWAY

37 Douglas Street, Hartford, CT. Every Sunday April 1st to Nov. 31st Black Top Oval. For more information call "Ziggy" or Debbie Kwasnicki (203) 246-4778.

HOBBY HAVEN RACEWAY

1756 First Street, Livermore, CA 94550 AC power, paved parking, computer scoring, trophy races, trophy dashes, gift certificates. Coming soon night racing & oval races. For info (415) 443-5828 M-F 10-6 p.m.

RADIO OPERATED AUTO RACING OF ROCHESTER

110 Anderson Ave., Behind Village Gate (274 N. Goodman St.)

7:00 p.m. - Monday Pro Night
7:00 p.m. - Tuesday Boy Scout Nite,
7:00 p.m. - Wednesday Teen Night
7:00 p.m. - Thursday Indoor Clay
7:00 p.m. - Friday Roar Meetings
7:00 p.m. - Sat. & Sun. Family Days

HOBBY HUT

2665 Park Marina Dr., Redding, CA 96001, (916) 241-3737. 1/10 Off-Road Racing. Norcal Mini Off-Roaders. Ask for Kevin Paschke.

USA RACEWAYS

6083 Dixie Highway, Bridgeport, Michigan, (517) 777-7USA.

Every Thursday Oval & Off-Road
Every Fri. Indoor Carpet Oval

R.C. BUGGYWORLD & RACEWAY

7511 Hamilton Ave. - RT. 127, MT. Healthy, OH 45231, 522-0809. Wednesday night off-road and oval on alter-

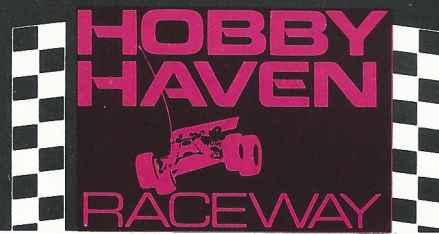

1990 ROAR OFF ROAD NATIONALS

HOME OF THE REEDY TOP GUN CHAMPIONSHIP & TWISTER OFF-ROAD CHALLENGE

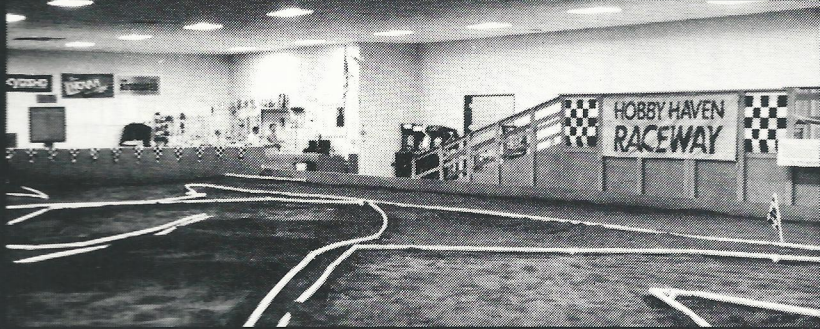

What people are saying about Hobby Haven Raceway:

"It's a high speed track"... Mike Reedy/Reedy Modifieds

"10"... Eustace Moore Jr./MIP Products

"One of the best"... Mike Walker/Twister Motors

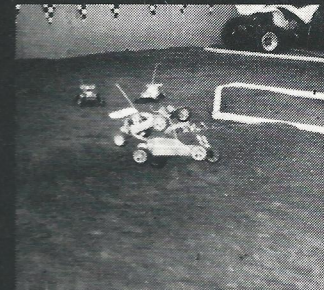

- One of the Largest Indoor Facilities in the Western United States — 16,000 Sq. Feet.
- Ample Paved Parking with R.V. Access.
- Complete Parts Department
- Climate Controlled Racing Environment-A/C & Heating
- Complete Deli/Snack Bar
- Easy Freeway Access From S.F./Oakland Bay Area and Sacramento Area.
- Rental R.C. Cars Available
- Weekly Races and Practice Times — Call For Information

Hobby Haven Retail Center
72 South N. Street
Livermore, CA 94550
415/443-5828

Hobby Haven Raceway
3983 First Street
Livermore, CA 94550
415/443-7826

Speedworks®

1990 Sportsman Triad™ Cup Series

Race 2, 1/10th off-road

SEMROCC

(Nationals Track)

July 6, 7 & 8

Sterling Heights, Mi

(313) 644-0669

See 10 of the Worlds
best drivers compete
in a special
invitational race!

Joel Johnson
Tony Neisinger
Bob Light
(Trinity)

Gil Losi Jr.
(Team Losi)

Rick Hohwarth
(Peak Performance)

Andy Dobson
(Compositcraft)
Etc., etc., etc!



Race 3, 1/10th on-road road race

RANCH PIT SHOP

October 5, 6 & 7

Pomona, Ca

(714) 623-1506

Non sponsored drivers only, Speedworks hand out stock motors, seminars by 10 of the top drivers in the World. Come to learn, race and be the "Speedworks Sportsman Triad Cup National Champion!" The overall champion will be crowned at the Ranch!

For more information please use the numbers listed for each event. All entries will be handled by the individual race. Trinity Products Inc. reserves the right to refuse any entry.

TRINITY®
2 TIME IFMAR WORLD CHAMPIONS

1901 E. Linden Ave#8 • Linden, NJ 07036 • Ph (201) 862-1705 • Fx (201) 862-6875



nating weeks. Also carpet races on Monday nights 40 x 80 banked oval.

OUTLAW MOTOR SPEEDWAY

7920 Webster, Highland, CA, (714) 864-1770. Tues. Tamiya Off-Road; Thur. Off-Road & Dirt Oval; Fri. 1/10 & 1/12 on-road; 1st Sun. Dirt Oval; 2nd Sun. 1/10 & 1/12 On-Road; 3rd & 4th Sun. Off-Road.

LITTLES HOBBIES

Monday Nite - 1/10 Trucks
Tuesday Nite - 1/10 Sprint Cars
Wed.-Fri. - Open Practice Available
Sat. - 11 a.m. 2WD 6 yrs. to 16 yrs.
Sun. - 11 a.m. - All Classes Indoor Clay Oval and Road Track Fast -Stock & Modified Classes. Bolink AMB Lap Counter. 111 Main St., Rt. 66, Hebron, CT 06248, (203) 228-4942.

R/C WORLD & TRACK

New indoor facility for 1/10 off-road and oval dirt racing. Wed. and Fri. -oval. Sat. Daytime and Evening off-road. Practice anytime. Call Glen or Debbie at (303) 789-0838, 2788 S. Federal, Denver, CO 80202.

FAST LANE R/C

On Road Asphalt Track. 21616 Golden Triangle, Saugus, CA. Call (805) 255-2404.

RPM R/C RACEWAY

1112 S. 16th, Elwood, IN 46254. Indoor off-road racing every Sunday at 12:00 noon. For info call (317) 552-7758.

REC. R/C RACEWAY

1/10 scale clay oval track. Racing Sat. - Oval 10-2:30 - Racing at 3:00 p.m. - Sunday - Off-Road 10-2:30 Racing at 3 p.m. Call Erin Clancy (914) 868-7715. Route 82 to Standfordville, NY 12581.

MADISON AREA RADIO CONTROL CAR ASSOCIATION, INC.

Factory Outlet Mall, Madison, Wisconsin. 1/10 and 1/12 scale carpet racing. Practice Sat. Afternoon Racing 6 p.m. Sat. & 7 p.m. Tues. George Jerdee (608) 873-7286.

THE RANCH PIT SHOP

1655 E. Mission Blvd., Pomona, CA 91766 (714) 623-1506. Every Wednesday night at 6 p.m. Alternating Oval and Off-Road.

COMPETITION HOBBY

Off-Road racing indoors on dirt. Every Wednesday night 6:30 - Sunday 12 noon, Juniors (12 and under) & Novice Saturday 12 noon. 8169 S. State St., Midvale, UT 84047, (801) 562-9452.

CONNECTICUT AUTO RACING TEAM
1/10 Off-Road and Sprint Car Oval. 37 Douglas Street, Hartford, CT 06114, Zig (203) 246-4778.

HOBBYTOWN

1/4 Mile High Banked Indoor Carpet Tracks at two of our stores. The Lincoln track is at our Sutter Place Mall store located at 5221 S. 48th St., Lincoln, NE 68516 (402) 483-7427. The Omaha track is located at Rockbrook Village at 11011 Elm Street, Omaha, NE 68144, (402) 391-5669.

Tues. - 7 p.m. - Lincoln
Wed. - 7 p.m. - Omaha
Sat. - 1 p.m. - Lincoln & Omaha
Sun. - 1 p.m. - Lincoln & Omaha

ROMAC

1/10 and 1/12 on large carpet oval (Northern Lights Mall) N. Syracuse, NY. Thursday evenings and Sunday afternoons. Information call (315) 468-1463 or (315) 468-6544.

COOPER'S RC RACE CENTER

Racing every Sunday 2 p.m.
Open Wed. and Fri. 6 p.m.
Open Sat. & Sun. 12 noon
Oval and Off-Road
Contact Norris, Rt. 4 Box 122B, Chatham, VA 24531, (804) 724-4182.

VICTORIA HOBBY SHOP

Every Saturday - 2 p.m. - Off-Road;
Every Sunday - 2 p.m. - Ovals.
5211 John Stockbauer, Victoria, TX 77904, (512) 575-3270.

M.H.O.R. R/C RACEWAY

155540 E. Batavia Dr., Aurora, CO 80011. (East on 17th Ave. at Chambers Rd.). Indoor 1/10 Off-Road Racing on Wed. & Sat. Practice/Track Time Tues., Thur., Fri., Sun. Complete Hobby Shop, pit area has AC & DC power, a nice clean handicap accessible racing facility. For info call Jess Brockman, (303) 343-0151 after 3 p.m. MST. Closed Monday.

HOBBYTOWN RACEWAY

4915 W. Elm, McHenry, IL 60050, (815) 344-1777. Hobbytown Raceway, 219 W. Cedar Lake Rd., Round Lake, IL 60073. Indoor - Dirt 80' straightaways, (312) 546-0707. Oval Racing every Friday 7 p.m.; Off-Road Sunday 10 a.m.

BNS COMPETITION HOBBIES

Route 7, Box 380, Anderson, SC 29624, (803) 224-8591. Contact Bob Sanford. Racing and Open Practice Wed. 6:30 p.m., Every Saturday 1:00 p.m. 1/10 Dirt Oval.

DESERT HOBBIES & RACEWAY

Off-Road racing 1st & 3rd Sundays. Sign in 10-11:15 a.m. Every Friday nite 7:30 p.m. 25 minutes from San Bernardino. 17210 Main St., Hesperia, CA 92345, (619) 94858.

TAIT'S HOBBY SHOP

Sat. Off-Road 12 noon, 2WD/4WD Monster Trucks. Sun. Dirt Oval 12 noon 2WD/4WD Any body style. Mon. Indoor Oval Carpet 7 p.m. 1/10 & 1/12. Tues. Truck/Car Pulls 7 p.m.. Wed. Outlaw Dirt Oval 7 p.m. 2WD/4WD Stock cars/ 2WD Sprints. Friday. Off-Road 7 p.m. 2WD/4WD Off-Road cars. 3270 Bay Rd., Saginaw, MI 48603, (517) 799-3900.

J.G.S.

Wisconsin's finest off-road race track. Perfectly groomed 100 ft. straightaway, computer scoring, drivers stand, starting lights. Racing every other Sunday 1 p.m. Menomonee Falls, WI (414) 255-2040.

TRACKSIDE RACEWAY

Dirt Oval Racing every Thursday night 6 p.m. Fully stocked hobby shop, com-

puter scoring, lights, bleachers, concessions. Menomonee Falls, WI (414) 255-2040.

WAGONHILL HOBBIES

Indoor 1/10 & 1/12 on-road racing every Friday night. Outdoor Off-Road every Saturday Night. 225 S. Board St. Grove City, PA, (412) 458-4711.

DIXIE R/C HOBBY SHOP

Every weekend Sat. & Sun. The races will alternate between oval and motocross starting May 14 with oval and May 15 with motocross. Dixie R/C Hobby Shop, P. O. Box 135, Ramseur, NC 27316, after 6 p.m. (919) 824-2770.

BREMEN RACEWAY

Clay Oval Track 60 x 100 ft. Under roof, lighted Friday nights 7 p.m. May thru Sept. Call for information (219) 546-3807. Bremen Hobbies, 308 N. Bowen, Bremen, IN 46506.

WEST TEXAS R/C RACEWAY

3477 Lee Blvd. - Racing every Sunday. 1/10 scale off-road and oval dirt. Mailing address: 301 Edith Dr., El Paso, TX 79915. For more information call Hector (915) 772-1382.

JIM'S R/C SPECIALTIES

3107 S.W. Van Buren, Topeka, KS 66611 (913) 273-4070. Racing off-road every Sunday 12 noon to 5 p.m. Oval racing every Saturday night 6 p.m.

EAGLE HOBBY CENTER & RACEWAY

Every Saturday night at 7:30 p.m. 1/12 4 cell stock and modified. 1/10 6 cell stock on-road, call for body style. Eagle Hobby Center & Raceway, 3601 Shepherd, Balch Springs, TX 75180, (214) 557-5290.

ACTION SPEEDWAY

Indian River's Facility

1/10 scale half mile clay oval & off-road. Two story covered drivers' stand, large pit area close to track, ample parking, classes for young and old, beginner's to expert's, and truck pulls. Coming soon - 1/10 scale super speedway and road course, night racing, full electric, and concessions. For further information call Trace or Chip Button (407) 231-9410 or Doug Upton (407) 569-8793.

THE INSIDE TRACK

Every Wednesday - 7 p.m. and Saturday 6 p.m. Classes: 2WD Stock and Modified, 4WD Stock and Modified and Monster Trucks. For more information call (312) 898-5649. 725 Hill Avenue, Aurora, IL 60505.

ABC R/C

Clay track racing every Saturday 1 p.m. Truck pulls every Tuesday 6:30 p.m. Complete R/C headquarters, 1441B E. Main Street, Waukesha, WI 53186, (414) 542-1245.

TC'S R/C'S

Inside and outside race track and RC shop. 1537 Freeport Road, Natrona Heights, PA 15065, call 226-8802.

BROCKTON INTERNATIONAL SPEEDWAY

Monday night 1/10 & 1/12 oval racing

Subscribe Today!



At A

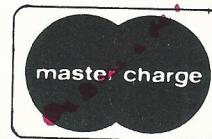

35% Savings Off Cover Price

TRIVIA
STRAIGHT LINE FEVER
TECHNICAL ARTICLES
PRODUCT REVIEWS
ON THE SPOT
PIT BOARD
PIT TALK

NEWSLINE
ASK THE EXPERTS
NEW PRODUCTS
HARD CHARGING
RACING SCHEDULE
WORLDWIDE RACE COVERAGE
IN DEPTH INTERVIEWS

CUT ALONG THIS LINE AND MAIL TO:

COMPETITION PLUS

16582 Gothard Street, Unit Q - Huntington Beach, CA 92647 - (714) 842-3881 - (714) 846-0403 - FAX (714) 848-2969

\$22.95 1 Year \$42.95 2 Years \$60.95 3 Years

Name _____

Address _____

City, State, Zip Code _____

Check Mastercard Visa Amount \$ _____

Credit Card # _____ Exp. Date _____

Signature _____

Add \$10.00 for First Class or Canada - Overseas Air Mail \$55.00 - Overseas Surface \$35.00

5:30 to 7:30 Practice. Races start 7:30 p.m. 1217 Main st, Brockton, MA. For more information call Ruben (508) 588-9355.

SONOMA COUNTY RACEWAY

806 Brookwood Avenue, P. O. Box 9565, Santa Rosa, CA 95405 -1/10 Dirt Oval, 1/10 Off-Road, 1/10 & 1/12 Asphalt. Mark White (707) 571-7565, Schedule info (707) 571-8044, Competition Products (707) 571-8048.

ALL IN 1 RACEWAY

5612 S. 108th St. Hales Corners, WI. 1/10 scale indoor dirt track. High speed semi-oval and true off-road courses. Practice Tues, Thrus., and Fri. 6 - 9 p.m. Racing Wednesday nights at 6 p.m., Sat. & Sun. at 1 p.m. For more information call (414) 425-4060.

THE SQUARE ROUNDHOUSE SPEEDWAY

Saturdays - 3 Events per month -Off-Road, Monster Truck Pulls and Oval Race. Oval dirt track and Off-road track. 1468 Lander Avenue, Turlock, CA 95380, (209) 668-4454, Ask for Harold Lindquist.

COASTAL BEND SANDBLASTERS R/C CAR CLUB

Races first thru 3rd Sundays, 2 p.m. start. Bill Witt Park, Yorktown Road, Corpus Christi, TX, Call Pete Broadway (512) 992-4448.

CAJON R/C SPEEDWAY

1875 Joe Crosson, El Cajon, CA 92020. Fastest paved oval & road course in CA. 1/10 & 1/12 scale. Please call for off-road dates. Hot Line (619) 449-0788/Track info 449-9948.

RADIO CONTROLLED HOBBIES & RACEWAY

Indoor Off-Road racing every Tuesday & Thursday evening beginning at 7 p.m. and Saturdays at 5 p.m. Open 7 days a week. 2011 Placentia Ave., Costa Mesa, CA 92627. For more info call (714) 631-1555.

R/C RACEWAYS

1/10 indoor dirt oval. 100' straightaways. Wed. 6 p.m. oval. Friday 6:30 p.m. oval. Sunday 12 noon oval or off-road. For more information call (219) 747-6414. 2710 Nuttman, Ft. Wayne, IN 46804.

R/C PERFORMANCE CENTER

Indoor high banked carpet oval. 170' x 90' off-road dirt indoor track. Racing 4 Days a week; Tues., Thurs., Sat. & Sun. Open 10 a.m. - 10 p.m. 7 days a week. 4 Manley Street, West Bridgewater, MA 02379. Ask for John (508) 588-9666.

PARLOR HOBBIES

Short Track Stock Car Racing on Road Courses. 1/10 on Asphalt - Full bodies - Grand National or ASA bodies preferred. Truck class with 1/12 on-1/12

Be a winner with Hyperdrive!

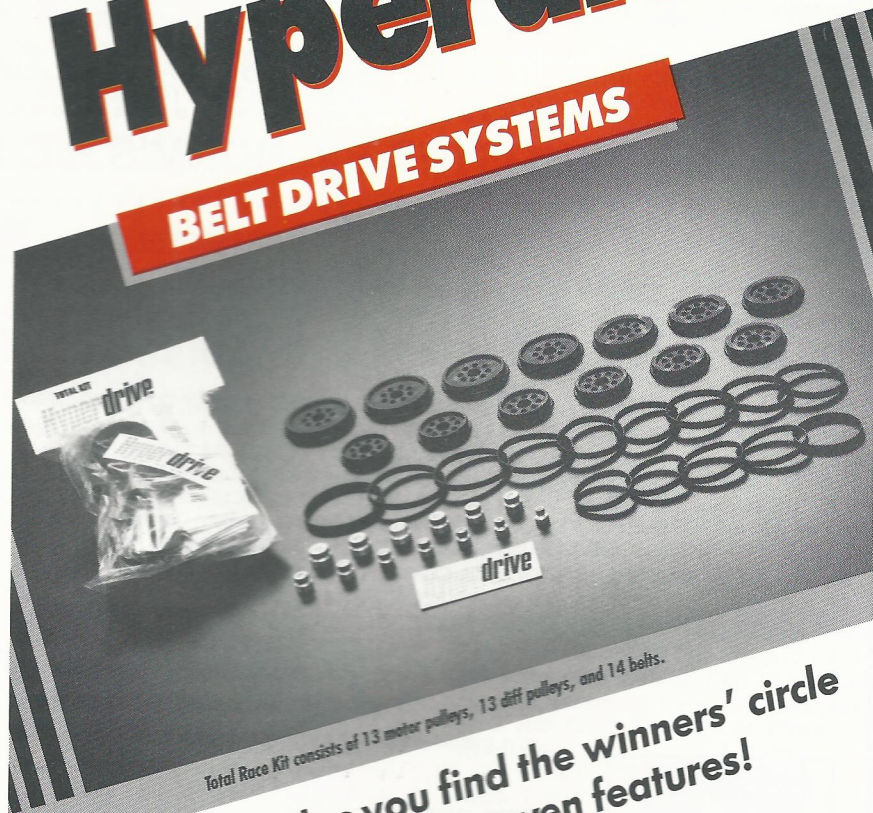

Total Race Kit consists of 13 motor pulleys, 13 diff pulleys, and 14 belts.

Hyperdrive helps you find the winners' circle with these competition proven features!

Be A Winner!

- Less friction and vibration means more horsepower and traction!
- Precision machined motor pulleys!
- Teflon impregnated diff pulleys - no diff lube necessary!
- 169 possible ratios with full race kit!
- Kits available for virtually all on and off road applications!
- All belts and pulleys may be purchased individually!

For parts, catalogs (\$3) with free stickers, or more information, call factory direct. Hyperdrive kits and accessories are also available through popular hobby shops and distributors. MC and VISA accepted.



3210 Howard Nickell Road • Fayetteville, Arkansas 72703
Phone (501) 444-8200 or (501) 444-8494
Fax (501) 444-8402

NORRCA

NATIONAL ORGANIZATION FOR RACING RADIO CONTROL AUTOS

1990 OFF-ROAD NATIONALS

JULY 6TH - 8TH DALLAS, TX

HOSTED BY NORM'S R/C HOBBIES

PRESENTED BY

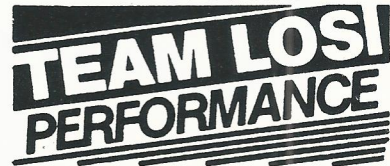

NORRCA MEMBERSHIP IS REQUIRED * (MEMBERSHIP IS AVAILABLE AT TRACK OR THROUGH NORRCA) * NORRCA RULES APPLY * NORRCA OFFICIALS WILL BE PRESENT * SHIRTS FOR PRE-ENTRANTS ONLY * NORRCA T.Q. PINS & TROPHIES FOR TOP QUALIFIER IN EACH CLASS * TROPHIES 1st -10th IN ALL "A" MAINS * 1-3 ALL MAINS * CONCOURS TROPHIES 1st -3rd * TROPHY DASH FOR EACH CLASS * HOST HOTEL IS THE "DALLAS RADISON" 2330 W. N.W. HWY, DALLAS, TX 75220, 214-351-4477 * YOU MUST ASK FOR THE NORRCA RACE RATE * AIRPORT AND RESTAURANTS NEARBY * 3RD ANNUAL NORRCA TEAM CUP CHALLENGE -THE TEAM WITH THE HIGHEST OVERALL POINTS WILL BE AWARDED A GOLD CUP FOR "THE BEST OFF-ROAD TEAM" OF 1990 * ENTRIES LIMITED TO 400. PRE-ENTRIES CLOSE JULY 1ST * ENTRIES DAY OF RACE IF AVAILABLE \$50.00 * STOCK MOTORS WILL BE SUPPLIED BY TRINITY * ADDITIONAL MOTORS WILL BE \$15.00

SCHEDULE: JULY 5TH PRACTICE ALL CLASSES 10AM-6PM * 6TH 6AM -8AM CHECK-IN, 8:30 1ST HEAT, 2:00PM BEGINS 2ND ROUND, JULY 7TH 7:30AM CONCOURS, 8:00 AM 3RD ROUND, 2:00PM 4TH ROUND, JULY 8TH 8-9 AM TROPHY DASH, 9:30 START OF LOWER MAINS. ALL SCHEDULED TIMES ARE APPROXIMATE. SCHEDULE MAY VARY AND CAN BE ADJUSTED AT ANYTIME *



***** ASSOCIATE SPONSORS *****



LC Sidewinder



NORRCA OFFICIAL 1990 OFF-ROAD NATIONALS ENTRY FORM

NAME _____ EXPERT _____ SPORTSMAN _____ PHONE _____

ADDRESS _____

CLASS(ES): 2W STOCK _____ 2W OPEN _____ 4W STOCK _____ 4W OPEN _____ OPEN TRUCK _____
SUPER STOCK TRUCK _____

2W FREQUENCIES 1. _____ 2. _____ 3. _____ SPONSOR(S) _____

4W FREQUENCIES 1. _____ 2. _____ 3. _____ CAR _____ MOTOR _____ RADIO _____

ENTRY FEE: \$35.00 1ST CLASS., \$25 EA ADD'L CLASS. EACH STOCK ENTRY \$40.00 (INCLUDES 1 MOTOR) NO ENTRY REFUNDS. SEND ENTRY & CHECK PAYABLE TO:

NORRCA, 1530 W. 8TH ST #117, UPLAND, CA 91786 FOR ADD'L INFO. CALL NORM'S AT 214-357-3453 OR NORRCA AT 714-981-9641

NORRCA # _____

off-road & hill climb. May 6 - May 20 - June 10 - June 24 - July 1 - July 8 - July 15 - July 29 - Aug. 5 - Aug. 12 - Aug. 19 - Aug. 26 - Sept. 16 - Sept. 23 - Sept. 30 - Oct. 7 - Oct. 14 - Oct. 28 - Nov. 4 - Nov. 11 - Nov. 18. Rabbit Lane & 34 Broad St., Matawan, NJ 566-3158.

R/C SPEED CENTER R/C ADDICTION

2810 N. Pacific Hwy., Medford, OR 97501. Call Gene or Betty Skelton. (503) 779-8298. 1/10 and 1/12 scale, banked dirt oval racing, dirt off-road racing, sled pulls, mudbog. Racing every week, year around.

BROTHER-IN-LAWS R/C RACING

1/10 scale dirt oval. Racing every Sunday. Signups 10 a.m. Open Practice 12-6 Tues. - Sat. pit tables, 110 volt power. Call Bob (619) 949-5252. 16175 Main Street, Hesperia, CA.

CORCAR - COLUMBUS, OHIO

1/10 off-road racing May thru Sept. every Sunday. Signups start at 10:30 a.m. Excellent dirt track, computer scoring and picnic area. For information call Ray Williams (614) 890-2983.

MACHESNEY PARK RACEWAY

1220 Shappert Dr., Machesney Park, IL. (815) 282-1311. Large asphalt oval, racing every Saturday and alternating Sundays, April thru October.

CENTRAL MARYLAND ELECTRIC RACING CLUB

(CMERC) Community R/C Speedway
Middletown Park, Middletown, Maryland. 100' x 50' dirt oval, 14' wide lanes, 2' banked turns, No electricity available. Every Saturday. Contact John Mauchamer, (301) 698-9545.

SCHENECTADY R/C SPEEDWAY

Indoor Oval Carpet Racing. 1/10 & 1/12 and Monster Trucks. 955 State St., Schenectady, NY, (518) 370-3747.

THE COCKEYSVILLE ASTRODOME

C.A.R. Cockeysville Astrodome Racers, Inc., 10854 York Rd. (Rear) Cockeysville, MD, (301) 666-1098. High Bank Oval racing on concrete (indoors). Benches, Power, Grandstands. 7 p.m. Mon. - Open Practice; 7 p.m. Tues. - Rookie & Stock Practice; 7 p.m. Wed. - Computer Organized Racing; 7 p.m. Thurs. - Modified & Ultra-lite Practice; 7 p.m. Fri. - Trucks & Buggies Practice; 5 p.m. Sat. - Computer Organized Racing; 1 p.m. Sun. - Computer Organized Racing. Art LaPole (301) 889-2070.

BOB'S R/C SUPPLY & RACEWAY

Indoor Carpet Racing! Tues. 1/10 Oval; Fri. 1/12 Road Course; Sat. Monster Trucks. Stock & Modified. Snack bar. Call Bob, Nancy or Kevin (319) 232-2235, 935 Sheerer Ave., Waterloo, IA 50701.

EBERSOLE HOBBY & R/C RACEWAY
Off-Road and Oval. Races Wed., Thurs., Sat., and alternate Sun. 11417 W. Highway 54, Wichita, KS 67209. Len Ebersole, (316) 722-8888.

METRO-FAST RACEWAY & HOBBIES

125' x 48' indoor carpet track, pitting for 140+, power, hobby shop, video entertainment, food bar. Oval - Fri., Kid's racing every Sat. morn and alternate Sun. on on-road & off-road. 950 W. Irving Park Rd., Hanover Park, IL 60103, (312) 213-3977.

MID-CAROLINA R/C SUPER

SPEEDWAY

The speedway is located on Flint Hill Rd. Off 1-77/Carowinds exit. So. of Charlotte, NC. 1/10 & 1/12 High-Speed Banked Quad-Oval and Road Course. 385 ft. plus 26 degrees banking in turns concrete track. Fred Penland (704) 373-2535 7:30 a.m. to 4:30 p.m.

BROWNIE'S HOBBIES

Off-Road Dirt Track, hobby shop. Wed. eves and Sat. afternoons for practice. Racing - Fri. eves. 4WD & 2WD. Track open April -November. 124 Bennett St., Staten Island, NY 10302, (718) 727-2194.

ROADRUNNER R/C CENTRAL

5620 Bellaire, Houston, TX 77081, (713) 661-7574. 1/12 Carpet Oval or Road Course Thurs. Nite. 1/10 Carpet Oval Tues. & Fri. nite & Sun. pm.

ROADRUNNER R/C NORTH

12760 Veterans Memorial, Houston, TX 77014, (713) 537-7758. 1/10 Dirt Oval Wed. Fri. nite. 1/10 Dirt Off-Road Sat. & Sun.

ROADRUNNER R/C SOUTH

12902 Player, Houston, TX 77014, (713) 728-2277. 1/10 Indoor Dirt Off-Road Wed., Fri., & Sat.

NORTHERN MINI-RACERS

NMR Raceway, P. O. Box 415, 3524 E. Burdick. Minot, North Dakota 58701. 1st & 3rd Sun. 1/10, 6 cell, NASCAR bodies, oval racing on carpet. Roger Lee, (701) 839-4731, 839-5294; Pat McWethy, (701) 839-8868, 852-6254.

ASHEVILLE HOBBY SPEEDWAY

Racing Wed. & Sat. - 7:30. 1/10 & 1/12 Asphalt Oval -Indoors. Hwy. 25, Naples, NC 28760, (704) 684-9814. Jack or Sharon Murdock.

HOBBY CENTER

High banked carpet oval track. Racing Fri. -7:30 p.m. 1/10 NASCAR, trucks, 2WD gearbox hot rod, 4WD wedge bodies, 1/12 scale. Any body ROAR stock motors all classes. Open practice during store hours. (502) 683-7611. 1233 Sweeney St., Owensboro, KY 42301.

R/C MOTORPLEX & HOBBY

Outside Tracks: One of Midwest's largest paved oval (160 x 115) with paved infield road course. Indoor Tracks: Dirt off-road & dirt oval. Carpet road course & oval. 1/12, 1/10 & 1/8. Snack bar, game room R/C hobby shop. 303 Herbert Rd., McHenry, IL 60050, (815) 385-1240. Bob Oaks or Jim Bostrom.

SACRAMENTO MINI-WHEELS RACEWAY

Indoor racing with 1/10 & 1/12 scale. Two tracks with off-road, dirt oval, and on-road. The on-road track is etched concrete. Racing Wednesday (off-road). Fri. (on-road). Every other Sat. (dirt oval). Sun. (off-road). 8711 Elder Creek Rd., Sacramento, CA 95826. Paul or Marge Schiager (916) 383-4011.

RAPID TRANSIT RACEWAY

2104 Broadway, Schenectady, NY 12306, (518) 372-0777. Summer Store Hours: Mon. - Fri. 4 p.m. - 10 p.m., Sat. 11 a.m. - 5 p.m.. Race Schedule: Mon, Tues, & Sat. Open for Practice. Wed. 7:30 p.m. Stock & Mod. Thurs. 7:30 p.m. Sprint Car. Fri. 7:30 p.m. Sportsman & Open Class.

NORTHERN ALBERTA SCALE

CAR AUTO RACING

1/12 and 1/10 On-Road Racing. 1/12, 4 cell indoors on carpet during winter. 1/

10, 6-cell outdoors during summer. Dean Simpson (403) 481-8634, 17319 69th Ave., Edmonton, Alberta, Canada T5T-3S7.

HOBBY CORNER RACEWAY

Sun. - alternating oval & off-road 1 p.m. Tues. - oval racing 7 p.m. Large indoor dirt oval track with 4 foot banks. 2195 E. Garfield, Decatur, IL 62526 (217) 429-4477.

PHILLY RADIO CONTROLLED RACERS R/C CAR CLUB

Announcing the opening of a paved race track for R/C 1/10 on-road. ROAR rules. Sun., April - November. 11 a.m.. 7790 Dungan Rd., N. E. Philadelphia. Jon (215) 224-4822 or Bernie (215) 831-1835.

ARVIN'S HOBBY CENTRE

1403 E. Spring St., New Albany, IN 47150, (812) 945-3745. We have a 2,600 sq. ft. carpet track which has moveable rails so that we can change the layout from oval to off-road. We run offroad and on-road cars on Saturday, Sunday, Wednesdays nights.

ISLAND HOBBIES & RACEWAY

Mon.: 2WD Monster Trucks - Stock, Monster Trucks 6-cell Mod.; Tuesday 1/10 Off-Road Stock, 1/10 Sprint Cars - Open; Wed. 1/10 On-Road, Stock NASCAR bodies, On-Road 6-cell Mod. GTP bodies; Thurs. 4WD Trucks - Open, 4WD Cars - Open, 1/12 On-Road Stock 6-cell. All racing starts at 7 p.m. Open practice Sat. & Sun. Contact Dave at (516) 234-7428.

D & T HOBBIES

Two tracks, off-road & high speed concrete oval. 1/10 & 1/12 Wed., Fri., Sat., and Sun. For specific, please call (219) 674-8533. 55575 Ash Rd., Osceola, IN 46561.

TEXAS R/C RACEWAY

Home of the Plano Outlaws

Tues. and Sat. - 1/10 On-Road; Fri. NASCAR nite; Sun. 1/12 On-Road. 75 Central Espressway at 15th St. Exit 29, Palisades Square Shopping Center, Plano, Texas. Call Jim (214) 517-7485 or Dean (214) 519-0324.

RACEWAY HOBBIES

Wed. 7 p.m. - 2WD & 4WD Off-Road; Sat. 1 p.m. - Off-Road & Oval. Lexington Shoppes, 6845 So. U.S. A, Port St. Lucie, FL 34952, (407) 468-4338.

TEAM R & R, INC.

Westminster, Maryland 21157. Indoor oval carpet racing, 1/10 & 1/12 scale. Racing every Sunday. For more info, phone (301) 848-2144 or (301) 876-2983.

SUMMIT SPEEDWAY

Indoor Dirt Oval - Every Friday Night 7 p.m. Sundays indoor or outdoor (weather permitting) off-road or oval at noon. Call (219) 489-RACE (7223). 1706 W. Till Rd., Fort Wayne, IN 46818.

K & M R/C SPEEDWAY & HOBBIES

735 Canal St., Stamford, CT 06902, (203) 967-7255. One of New England's Largest Indoor Tracks. Weekly Hours Mon.-Fri. 4 p.m.-10 p.m.; Sat. & Sun 12 p.m.-10 p.m. 7,000 sq. ft. complex, ample pit area with power, 110' x 35 sq. ft. track anti-static carpet, fully stocked hobby shop. Organized racing held on a weekly basis. Call for details.

ALCAR INTER. R/C RACEWAY

Off-Road Fri. nights, 1/12 & 1/10 carpet Sundays, Closed Mondays. Hobby shop

ON-ROAD RACING JUST GOT FASTER.

Introducing the NEW PRO-LINE® On-Road Tire Series.

- ▶ Advanced Racing Compound for longer runtime and better acceleration.
- ▶ Lifetime Guarantee on the wheel for the life of the tire.
- ▶ Soft, medium and firm mixtures that maximize traction in varying race conditions.
- ▶ Each individual tire is mounted, trued to .002 total runout and balanced.

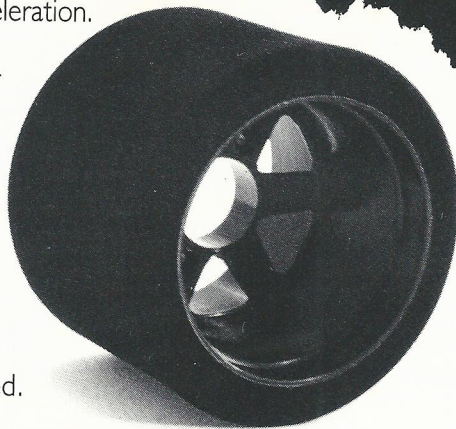

Compare and you'll be convinced . . . there's no contest.

P.O. Box 456
Beaumont
Calif. 92223
(714)849-9781

PRO-LINE®

Ask your local dealer for the NEW ON-ROAD SERIES (Stock Numbers #2001-#2006)

Send \$2 For Our Full Line Catalog

& snack bar. 33501-A Lake Rd., Avon Lake, OH 44012, (216)933-6017.

MARYLAND R/C CLUB

1/10 & 1/12 Scale Racing

Indoor Carpet racing

Contact Toy World R/C, (301) 424-0430.

R.C.A.R. of TULSA

Indoor Racing. 10404 E. 55th Place, Unit A, Tulsa, OK. March 3, 10, 17. Track Opens 6 p.m. Qualifying begins 7 p.m. For more info call Dave Cole (918) 745-9898.

HOBBIES ETC. RACEWAY

Medford High School, Winthrop St., Medford, MA. Every Sunday. Doors

open at 12 noon. Racing at 1 p.m. Indoor on-road carpet course for 1/10 and 1/12 scale. Computer lap counting, trophy and gift certificate awards. Ample parking, AC power, technical aid, hobby shop and concession stand on sight. For more info call (617) 389-3331.

AMERICAN ANGLER TACKLE & R/C HOBBY CENTER'S "AA RACEWAY"

1617 Toomey Rd., Austin, TX 78704, (512) 474-8277. Two dirt tracks, Oval & Off-Road. Races every Sunday, 1 p.m. Tracks Alternated. Races Every Saturday 11 a.m. Oval. Hobby shop on site.

REMOTE HOBBY'S INDOOR RACING

Shop (803) 736-9446, Track (803) 699-0528. 9005 C Two Notch Rd., Columbia, SC 29223. Fri. nites - Oval 1/10 Pan/Trans. Sat. nites - Road Course 1/10 Pan/Trans/Trucks. Pits for 40+, Parts, Power and Refreshments.

MacKAY RACEWAYS

1/10 Electric Off-Road Sundays. 1044 West 14th Street, North Vancouver, BC Canada. 150' straights/5'banks/moguls & jumps. Operated by the Western Canada R/C Club. For info call Dana Shaw (604) 980-4504.

ANTIOCH RACEWAY

1/10 dirt oval racing every Fri. 7 p.m. 1/10 off-road every Wed. 7 p.m. All Classes. Sat. & Sun. 1/10 dirt oval and off-road 10:30 a.m. Also night racing. Pit Tables, Power, open 7 days a week. 5631 Lone Tree Way, Antioch, CA 94509. Call (415) 754-5700 Jack Hanson.

CLEVELAND RADIO RACEWAY

3209 Lorain Avenue
Cleveland, OH 44113

For more info contact Troy Singer (Owner) (216) 741-1649 or Rick Moore (Race Coordinator) (216) 255-5429 Fri. 7-Midnight Oval or Off-Road; Sat. Noon - 6 p.m. Practice; Sun. 10 a.m. - 6 p.m. Oval or Off-Road. Classes: 2WD Stock & Modified; 4WD Modified & Monster Trucks.

SWEET UNION R/C RACEWAY

1/10 Dirt Oval & Off-Road. 388D Quarry Rd., Monroe, NC 28110. 300' 4 Turn Oval, 520' 19 Turn Off-Road (Shortest Line Measurement). "TrackMate" Lap Counting & MGT System. Racing Sat. & Sun. 1st & 3rd Weekends. Covered Driver's Stand, Trophies & Door Prizes Each Race Day, For more info Call (704) 289-3621.

NORTHSTAR RACEWAY

Featuring Minnesota's first indoor & outdoor clay oval and off-road surfaces. Fully stocked, specialized hobby shop. 10751 University Ave., Blaine, MN 55433, (612) 757-0374. Tues. - 7 p.m. off-road; Thur. - 7 p.m. oval racing; Sat. - 11 a.m. off-road racing. Send S.A.S.E. or call for complete schedule.

SIDEWAYS CITY

22,000 sq. ft. Building, racing every Tues. & Fri. nite and Sun. afternoon. Hobby shop, hot food concession, video game room, and kiddy land. The track is a super speedway cement oval. Dirt track open May thru September. Call (616) 792-2004 for further info. Located in Wayland, MI. Take US 131 to the Wayland Exit, turn East to light, turn North 1/12 mile.

RIVER CITIES R/C RACEWAY

Ashland, Kentucky 41101
Racing at 5:30 Saturday evenings under

a light area. Radio impound, concession booth, IBM Computer, Brimstar Management System, and AMB Lap Counter and P/A system. The track is a semi-hard dirt oval, 90' straight with 12' lanes and 60' across. Corners are banked approximately 15 degrees with 14' lanes, ample room for passing. Call Randy Aust (606) 836-4273 or Jason Graham (606) 836-2613.

SMR/CRC

First Sunday of Each Month at G.I.A. 1660 Stewart Street, Santa Monica, CA. Sign-up 8:30 a.m., Practice 9:15 a.m., Qualifying 10 a.m. For more information call Glenn Williams (213) 734-7888, Chris Chan (213) 393-3735, Tom Wong (213) 821-5472.

TARCAR - TOLEDO AREA

New black clay tri-oval. 1/10 oval and off-road. Sunday late April thru Mid-October. For more info call Dave Scanes, (419) 893-1916.

ACTION R/C RACEWAY

New Hampshire's finest indoor carpet high banked oval. AMB scoring, hobby shop, snack bar, rentals. 1/10 scale all classes including monster truck pulling. Family Fun Hobbies, 201 Washington St., Claremont, NH. Convenient to I-91 & I-89. 2 Hours from Boston & Hartford. Open 7 Days. (603) 543-1022.

WESTSIDE HOBBIES

Asphalt racing every Sunday. Sign-ups start at 9 a.m. Races start at 11 a.m. Alternating oval & road course. 1/12 & 1/10 on-road, 1/10 off-road cars and trucks, all classes. Full line hobby shop. For further info call Tom, Mark or Tim Minster. (915) 585-1864. 7214-A N. Mesa, El Paso, TX 79912.

R.R.O.L.

1/12 carpet racing Tuesdays, 1/10 carpet racing Wednesdays. Sept. to May, Asphalt & Off-Road in Summer. Remote Racers of London, P. O. Box 7241 Stn. E. London, Ontario, N5Y 4J0 Canada. Dan Engelbreth (519) 668-0427.

R.C. CITY RACEWAY & HOBBIES

Off-road racing every Tues., Fri., Sun., Oval racing every Sat./Practice time and rentals available. Call for more info. (408) 262-3188. 1453 N. Milpitas Blvd., Milpitas, CA.

— 1/12 Scale —

FLORIDA STATE SERIES

May 5 & 6 - Fort Lauderdale
July 14 & 15 - Rockledge
Sept. 15 & 16 - Orlando
October 13 & 14 - Pinellas Park

November 10 & 11 - Naples

GLASS CITY RADIO CONTROL

Racing 1/10 & 1/12. Clayton White (1/12) (419) 882-2518 or Mike Marshall (1/10) (313) 241-5321.

S.T.A.R.C.

Wed. Night - S.T.A.R.C. Club Series. Rockton, Ontario, Canada. Sam Burke (519) 621-5424.

TEAM RACE R/C CAR CLUB

Fri. 6:30 p.m. indoor track, 505 Spring Ridge Rd., Clinton, MS. (601) 924-0722.

NORTHERN MINI-RACERS

NMR Raceway, P. O. Box 415, 3524 East Burdick, Minot, ND 58701. 1st & 3rd Sat., 1/12, 4-cell, Can-Am/GTP bodies, road racing on carpet. Roger Lee, (701) 839-4731 or 839-5294. Pat McWethy, (701) 839-8868 or 852-6254.

KOUNTRY KLIN HOBBY

1/12 scale small indoor carpet track & hobby store. Box 247, 324 Railroad Ave., N. Mohall, ND 58761, (701) 756-6307.

USA RACEWAYS

6083 Dixie Highway, Bridgeport, Michigan 48722, (517) 777-7USA
Tue. Nite On-Road; Sat. Nite On-Road;
Every Other Sat. Eve. Stock On-Road

THE RANCH PIT SHOP

1655 E. Mission Blvd., Pomona, CA 91766. (714) 623-1506. Every 4th Sun. 1/12 & 1/10 On-Road Combined Program.

OMAHA NEBRASKA RADIO OPERATED AUTO DRIVERS

Very active racing schedule. Carpet and Pavement racing in 1/10 and 1/12 scales. All classes - Oval and road course. ROAR rules. (402) 331-2907.

S.O.R.C.R.C.C.

Southern Ontario Radio Control Race Car Club in Toronto, Ontario, Canada. Racing Alternating Sun. nites October - April. 6 p.m. to 10 p.m. Scott Reynolds 298-4941 or Gary Joi 421-9061.

CENTRAL MARYLAND ELECTRIC RACING CLUB

Middletown Park, Middletown, Maryland. 100' x 50' dirt oval, 14' wide lanes, 2' banked turns, drivers stand, no electricity available, open to the public. Mark Coats (301) 694-7420.

HOBBIES PLUS & R/C RACEWAY

1/10 & 1/12 scale indoor carpet racing. Tri-Oval & on-road, 60+ pit areas w/ electric, hobby shop, 7 days, open practice. Also Sun. A.M. 1/10 off-road dirt (150 x 70) and 1/8 gas off-road. 650 Amherst Street, Nashua, NH 03063, (603) 882-9200.

CARPETBURNERS R/C CLUB

436 East Main St. (Rear), Danville, IL 61832. (217) 442-7466.

CAPITOL DISTRICT R/C OUTLAWS

4 Cell Carpet Cars. NASCAR bodies,

Oval and Road Course. Every Friday Night at 7:30 p.m. October to the End of April. For further info contact Capitol District R/C Outlaws, 223 Fourth St., Scotta, NY 12302, or Sam Roberts (518) 374-3801.

JAY'S R/C

5018 14th Street West, Bradenton, FL 34702, (813) 756-6393, 758-2565, 746-8649. AMB Computerized lap counting. Indoor carpet oval and road course.

— SPECIAL EVENTS —

ROAR NATIONALS SUPER TOUR

Dirt Oval

May 10-13 - Euless, TX
Tom Mix (817) 595-1189

Paved Oval

May 24-27 - Snellville, GA
Roy Kelley - (404) 985-1448

1/10 & 1/12 On-Road

June 14-24 - Plano, TX
Dean Densmore - (214) 519-0324

1/10 Off-Road

July 19-29 - Livermore, CA
Tom Welding, Jr. - (415) 443-5828

1/8 Gas

Aug. 30-Sept. 3 - Dallas, TX
Joe Sullivan (214) 238-0929

NORRCA NATIONALS

1/10 Off-Road

July 6-8 - Dallas, TX
Norm's R/C Hobbies
(214) 357-3453 or
(714) 981-9641

Pavement Road Course

June 1-3rd - Bakersfield, CA
Racers Haven
(805) 835-0441 or
(714) 981-9641

SPEEDWORKS 1990 SPORTSMAN TRIAD CUP SERIES

SEMROCC

July 6, 7, & 8
Sterling Heights, MI
(313) 644-0669

RANCH PIT SHOP

October 5, 6 & 7
Pomona, CA
(714) 623-1506

□CP

**SIGN UP NOW, DON'T BE LEFT OUT!!!
THE ORIGINAL & MOST PRESTIGIOUS DIRT OVAL RACE IN AMERICA!**

JUNE 7-10, 1990

**At Racer's Haven
Bakersfield, CA**

**1/10 Scale Oval FULL BODIES, Outlaw Sprint Cars &
2WD & 4WD Modified Trucks**

Thursday Practice - Friday 3 Rounds of Qualifying
Saturday Concours, Qualifying 3 Rounds, Best Engineered
Sunday Trophy Dash, TQ Run, Mains
ROAR Membership Required

2WD Mod. - 4WD Mod. - Outlaw Sprint Car
2WD Mod. Monster Truck - 4WD Mod. Monster Truck

- Everyone runs in a main - 1st, 2nd, 3rd place trophies
- Running Concours - 1st place trophies - Sprint Car/Full Bodies/Trucks
- Trophy Dash - Fastest four/two minutes - 1st place trophy
- TQ Run - TQ's in each class will run against each other, with handicap start - 4 minutes - 1st place trophy
- Best Engineered - 1st place trophies - Sprint Car/Full Bodies/Trucks
- All A Main drivers will trophy
- Custom Jackets for A Main Winners - Custom hat pins to all entries.
- Overnight Camping at track NO CHARGE
- Total computerized scoring
- Host Hotel: TravelLodge South, 3620 Wible, Racer Discount, (805) 833-1000.

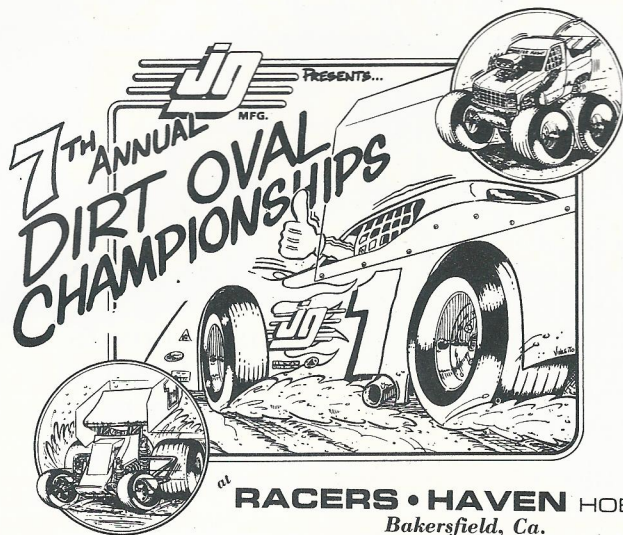

RACERS • HAVEN HOBBIES
Bakersfield, Ca.

ROAR SANCTION # 1-90-3

OVAL RULES

1. American cars only. Outlaw Stock ASA - NDRA Grand National Bodies Only. Handmade or Prototype okay. Spoilers and side dams no limit.
2. 4 minute heats - 6 heats per class
3. All A Mains are twin (2) 4 minute mains to determine winner.
4. Sprint Car Class - 2WD modified motors. 7 cell, wings, guts! Top wing 6" x 6" max. Sides 4 1/2" x 6 1/2" max:
5. Sprint car minimum weight 3 1/2 lbs. steel or aluminum cage, nerfs, rear bumper, headers may be lexan, top wing mandatory, front wing optional.
6. 2WD Modified minimum weight 3 1/4 lbs. and 4WD Modified minimum 3 1/2 lbs.
7. Maximum wheel width all classes 9 7/8".
8. 2WD and 4WD Modified cars, no CanAm or Off-Road type wings.
9. 2WD and 4WD Modified cars, rear spoiler must be attached to extreme rear of car BODY. Side dams no limit.

MODIFIED 2WD & 4WD MONSTER TRUCK CLASS RULES

1. Wheels: Minimum diameter of 2.2" Width minimum 2". Maximum Total Truck Width of 13".
2. Tires: Minimum diamter of 3 1/2".
3. Shocks: No limitation.
4. Speed Control: Any speed control may be used.
5. Body & Chassis: any chassis may be used. Truck Bodies Only.
6. Steering: No limits.
7. Weight: Minimum 4 lbs.
8. Batteries: Sub "C" type with 7 cells maximum.
9. Motor: Modified class as designated in "Modified Class" rules.
10. Side Fins & Wing: Wings are not allowed. Side dams max. height 2 1/2" from rear of cab back, extending no more than 2 1/2" behind bed.
11. Spoiler: A spoiler may be used off the rear of the body with a maximum height of 2 1/2".
12. Drive Train: 2WD rear wheel drive only. 4WD class must be 4WD.

PRIZES! PRIZES! PRIZES! - Out of State - Longest Haul - Prize - Dremel Tool Kit

Race Prizes donated by the following: MIP, McAllister, Speed/Sport, Associated, BoLink, RPS Dist., Parma, Cox, Radio Controlled Hobbies, Novak, ProLine, RevTech, Reedy Modifieds, Team Checkpoint, MRP, JG Mfg., RacePrep, Premier Designs, Twister, Robinson Racing Products, Custom Works R/C, Dan's R/C

RACE TO BE HELD AT: RACERS HAVEN - 7401 White Lane - Bakersfield, CA 93309 - 1-805-835-0443 - 1-805-835-0441

- Limit First 300 Entry Entries (Add \$5 per class for late entries after deadline)
- Qualifying Heats start at 9 a.m. Fri., June 8, 1990
- Sunday, June 10, 1990 - All main events 10 a.m. • Cars will be teched • Concours & Best Engineered, Saturday, June 9, 1990 9 a.m.

**FREE T-SHIRT WITH ENTRY - ENTRY FEE \$25.00 - EACH ADDITIONAL CLASS \$15.00 - Make Check Payable to: JG MFG - Deadline for Entries June 1, 1990
YOU CAN ENTER THREE CLASSES ONLY - ABSOLUTELY NO ENTRY FEE REFUNDS**

Name _____

Address _____

City, State/Country, Zip _____

Class: Outlaw Sprint Car _____ 2WD Modified _____ 4WD Modified _____ 2WD Mod. Monster Truck _____ 4WD Mod. Monster Truck _____

Frequencies: (Color) 1. _____ 2. _____ 3. _____ Radio: _____

Type of Car: (Make) _____ Motor: _____ Sponsor(s) _____

Mail to: JG MFG., P. O. BOX 6014, WHITTIER, CA 90609-6014

For more information call Racers Haven (805) 835-0443, (805) 835-0441 or JG Mfg. (213) 947-1206

Lowest qualifiers must be able to change bands.

NEW PRODUCTS



#9002 Team Trinity Shirt. This attractive and colorful T-Shirt is something you must have. You will bring attention to yourself when wearing Trinity. S, M, L, XL, XXL, XXXL. \$12.50 - #0420 Speedworks T-Shirt. This fluorescent colored shirt is the colors of the 90s. The two-sided t-shirt is something everyone would love to have! S, M, L, XL, XXL, XXXL. \$12.50. Trinity Products, 1901 East Linden Ave., NJ 07036, (201) 862-1705-08, FAX: (201) 862-6875.

NOW!!! Get the same brush alignment on your stock motors that modified racers have enjoyed for years. The "Brush Hood Alignment Tool" lets you "Blue Print" the alignment of your stock motors brush hoods to exactly 180 degree apart. For the first time you can adjust your stock motors and bring them into the same specs that the engineers designed them to run. \$39.95. Fast Racing Products, 4320 Puddelock Rd., Prince George, VA 23875, (804) 732-1210.

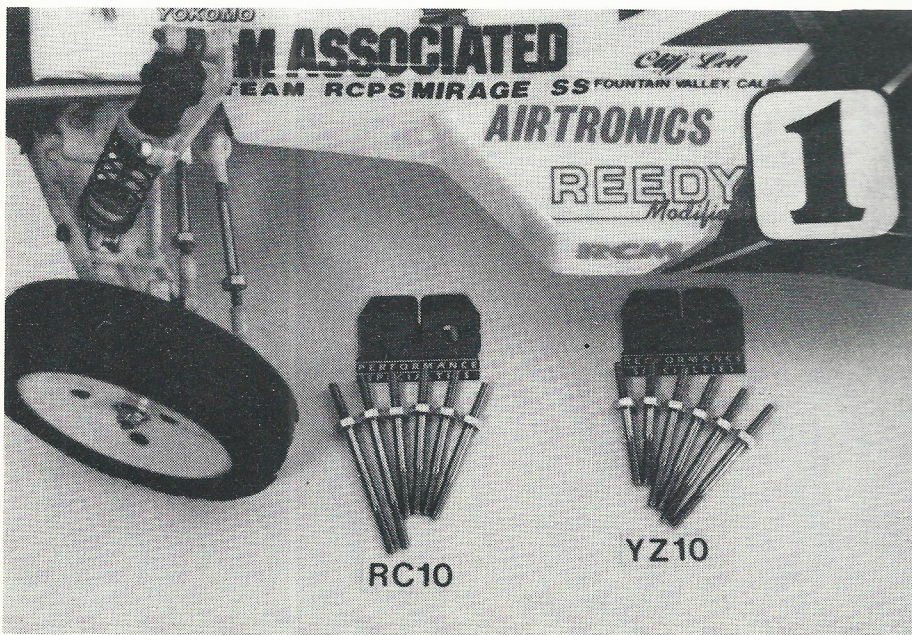
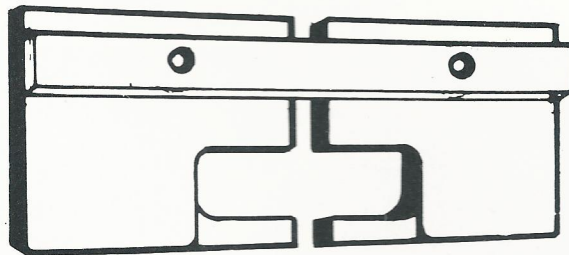

RC10 and YZ10 Titanium Turnbuckle Sets - These turnbuckles are made of the strongest and lightest titanium available. Increase the reliability of your car while shedding some weight in the process. Part #710 (RC10) and #750 (YZ10). RC Performance Specialties, 18312 Gifford St., Fountain Valley, CA 92708, Phone (714) 962-6928, Fax (714) 962-4089.

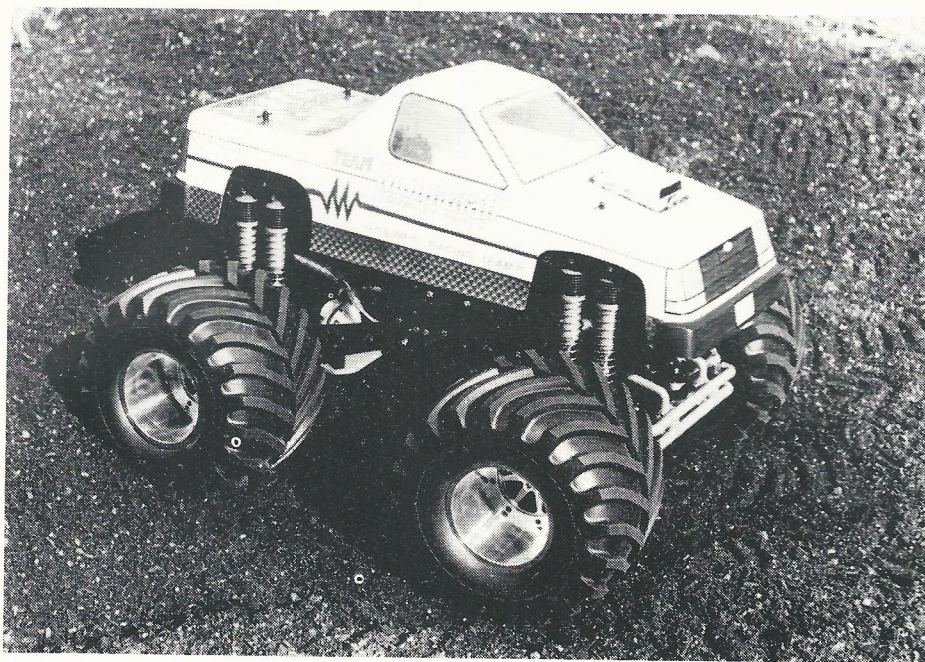

The TUFF-E-NUFF Ford Ranger Racing Truck Body (#D190 Retail \$19.98). The TUFF-E-NUFF lexan body is designed to fit most 1/10 scale monster trucks, off-road cars and on-road cars. The TUFF-E-NUFF racing truck body is shown on the Clodbuster 1/10 scale monster truck. TUFF-E-NUFF features a swept back front end, supercharger with scoop, sleek cab and narrow body. The TUFF-E-NUFF is painted white with blue LASERFIRE (D200) side panels and bed cover. Red STARFIRE (D260) shockwaves, Sky Blue INSTANT TINT (D811) tinted windows, black bumpers and grill and a silver supercharger and scoop. Dahm's Racing Bodies, P. O. Box 360, Cotati, CA 94931-0360. (707) 792-1316.

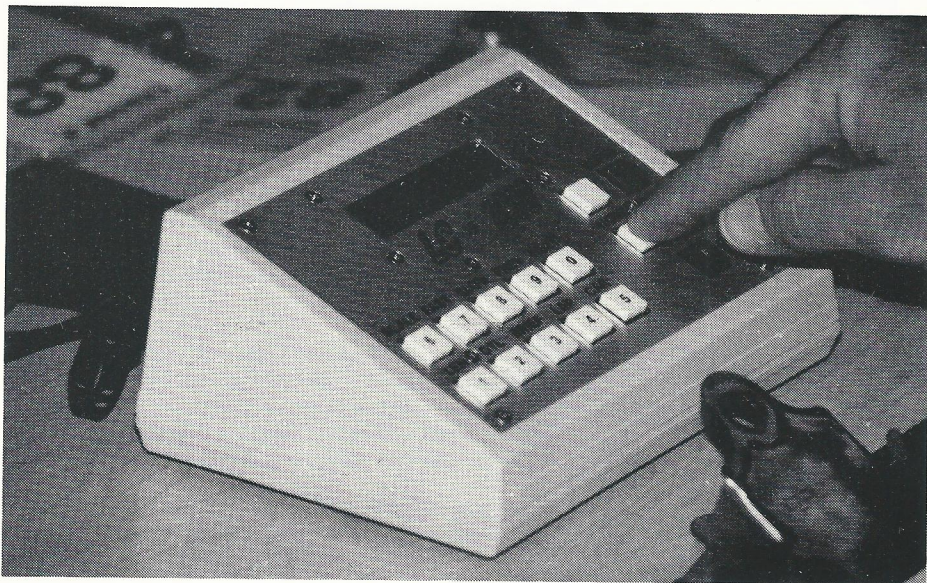

The future is here with the new LC-1000 Race Management System. The race to develop the finest lap counting system available at an affordable price for both clubs and competition racing is over and Neron Associates has won hands down!!! Over three years ago Neron Associates introduced the concept of individual hand held lap count actuators interfaced with an inexpensive computer system to provide accurate racing results. You know that system as the RACE DIRECTOR and since its introduction our systems have been purchased by tracks and clubs around the country and in Canada. Based on our knowledge of R/C car racing, software and hardware designs and information obtained by speaking with so many of you, Neron is pleased to introduce the next generation in R/C car lap counting, the LC-1000. Contact Neron Associates, P. O. Box 348, Germantown, MD 20875, (301) 972-0397.

Advertiser's Directory

A & D RACING	71
ALCRAFT	81
ANDY'S PRODUCTS	14
ARISTOTLE THROTTLE	37
ASSOCIATED	56, 73
B & B SOFTWARE	86
B & T RACING	79
BOCA BEARING	76
BOLINK	6 & 7
CKW	15
CLASS RECREATIONAL	28, 31
COMPETITION BATTERIES	80
COMPETITION PLUS	92
CONTROL ROOM	59
COORDINATED DATA	47
CORCAR RACE	72
COX HOBBIES	Inside ft.
CUSTOM SCALE COMP.	27
DAHM'S	55
ENDURANCE RACING	41
ERI	65
FAST RACING	10
FINE DESIGN	57
FIVE STAR	77
FUTABA	99
HOBBICO	4, 12
HOBBIES PLUS RACE	11
HOBBY HAVEN	89
HOBBY HAVEN RACE	88
HobbyShopper's Guide	24, 25
HORIZON HOBBY	17
HOOSIER CHAMPS	44
HOT LAPS	57
HYPERDRIVE	93
JG MFG.	70
JG MFG. RACE	98
KIMBROUGH	21
KING'S R/C	87
KYOSHO	4, 48, 49
LEADING EDGE	23
MEGATRAK	82, 83
MID-CAROLINA RACE	73
MODELER'S HAVEN	60
MRC	Back Cover
NERON PRODUCTS	35
NORRCA RACE	34, 85, 94
PARAGON	16
PARMA	INSIDE BK. COVERS
PEAK PERFORMANCE	66
PRO-LINE USA	96
PRO SHOP	47
RC PERF. SPECIALTIES	77
RACER'S CHOICE	13
RACER'S HAVEN RACE	58
R/C SUPERDROME	26
REEDY MODIFIEDS	76
REG. 1 OFF-ROAD	64
REG. 2 OFF-ROAD	69
REG. 3 6-CELL	78
RYDIN R/C	36
SEMROCC TRIAD RACE	32
STAGE III	84
TEAM LOSI	38, 39
TEAM PIT STOP	29
TEAM VOLCANO RACE	54
TEKIN	67
TECH TOYS RACE	61
TEXAS CONNECTION	51
T. M. RACING	45
TRACK MASTER	68
TRACK MATE	46
TRINITY PRODUCTS...3,9,30,52,53,76	
TRINITY RACES	90
TWINN-K	18
TWISTER MOTORS	20
VICTOR ENGINEERING	22
VERONA RACING PROD.	33
WAGON HILL HOBBIES	40

MAGNUM FORCE.



Tony Neisinger wins the 1989 Futaba Grand Prix with Magnum.

Every race day, more and more Magnums are showing up at the track. That's because Futaba makes a complete selection of Magnum pistol-grip systems to suit every kind of radio

controlled car. Each Magnum system is loaded with competition features to give you an edge, whether it's your first race or the World Championships.

Get a grip on our hot, new 2PB/Sport. With a price as comfortable as its ergonomically designed case, the Sport is the perfect Magnum for the beginner. Servo reverse switching and convenient throttle and steering trims make set-up in any car or boat easy, and the Sport ESC option includes our MC112B MOS/FET speed control with reverse.

MOVE INTO THE WINNERS CIRCLE

Our grown up Magnum 2PBKA/Junior gives you some extra moves to put on the competition. Full range steering rate lets you perfectly balance your car's



2PB/Sport

(2PB and 2PBKA available with MC112B speed control)



2PBKA/Junior



2PD/AM

(2PD and 3PB available with S9301, S9601 or S132H servos)



3PB/PCM1024



THE ALL NEW MAGNUM AM

The Magnum 2PD/AM is just what the serious racer ordered. Compact, yet fully equipped with pro-style, fine tune controls like steering rate, brake trim, throttle ATL, ATV and sub trim. The Magnum AM transmitter also lets you customize wheel throw and spring tension.

Like all Magnum 2 channel systems, the 2PD includes our new, narrow-band R102JE receiver. S9301 servos, the choice of most top 1:10 on and offroad drivers, are included, or you can choose S132H or S9601 versions.



Servo reversing, throw adjustment and sub-trimming can be individually preset on the 2PD control panel.

THE ULTIMATE MAGNUM

Racers who want it all turn to the awesome Magnum 3PB/PCM. The 3PB has everything you need for world class competition, in any class. Electronic trimming with sub trims and LED readouts, programmable mixing, dual rates and exponential, plug-in RF module, DSC and more make the 3PB a uniquely refined and versatile performer.

And the incredible interference protection and resolution of Futaba's exclusive PCM 1024 put it in a class by itself.

MAGNUM
Futaba

Futaba Corporation of America
Four Studebaker, Irvine, CA 92718

3 Steps to a great body

Parma International is the undisputed world leader in vacuum-formed lexan bodies, and for good reason. We work very hard to give demanding R/C enthusiasts like yourself what they ask for; **nothing but the best!**

For over 16 years, racers and hobbyists have trusted the quality and integrity of Parma's world class lexan car and truck bodies. Our "classic" body designs are unsurpassed in detail and clarity. Our On-Road, Off-Road, and new Pro Series wind tunnel tested racing shells are proven winners.

1 A body shell begins in Parma's R&D Department where technicians monitor new trends in real car automotive design and technology. We go to great lengths to collect data and reference materials on the very latest designs. Often, this means traveling to races, car shows, and museums to gather photographs of prototypes and classics. Then, skilled draftsmen use computerized design tools to translate the real car photos into accurate, scale reproductions. Next, the drawings are discussed and critiqued to make certain that the reproduction has maintained the integrity and "presence" of the original. If changes must be made, the drawings are resubmitted for another review. This kind of critical comparison should be expected from a company who stakes their reputation on producing the **best lexan bodies in the world.**

2 Once the drawings have met our specs, they go into the Mold Department for the most important step. This is where qualified master carvers using space age materials, turn the drawings into a 3-dimensional mold. Once the carving is complete, it too is evaluated for shape and detail. Occasionally minor corrections are necessary to be certain the detail will not be lost in the vacuum-forming process.

Before the mold is cast, the Parma Pro Series racing bodies are wind tunnel tested. Often radical changes may be made to these very special bodies to give today's competitive racer the advantage of maximum aerodynamics.

3 Once the carving meets our strict guidelines, it goes through a secret three step process. The result is a final copy of the mold for production purposes. But the approval process does not end here. Now

sample bodies are pulled and inspected for clarity and detail. If the detail is not reproducing well, the mold goes back for additional changes. Only when the mold is perfect can it go into production. But you would expect that from the **world's best lexan body manufacturer.**

What does all this mean to you? It means that when you get to the track for serious racing or concours competition, you can trust Parma bodies to perform and look great. Next time you pick up a body, choose Parma and see for yourself. When we say we make the best vacuum-formed, lexan bodies in the world . . . **We're not just sucking air.**

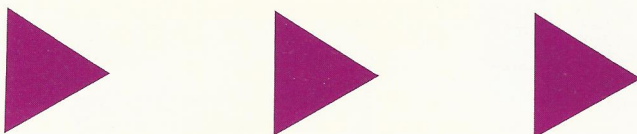

When We Say We Make The Best Vacuum-Formed Bodies In The World ...We're Not "Just Sucking Air"

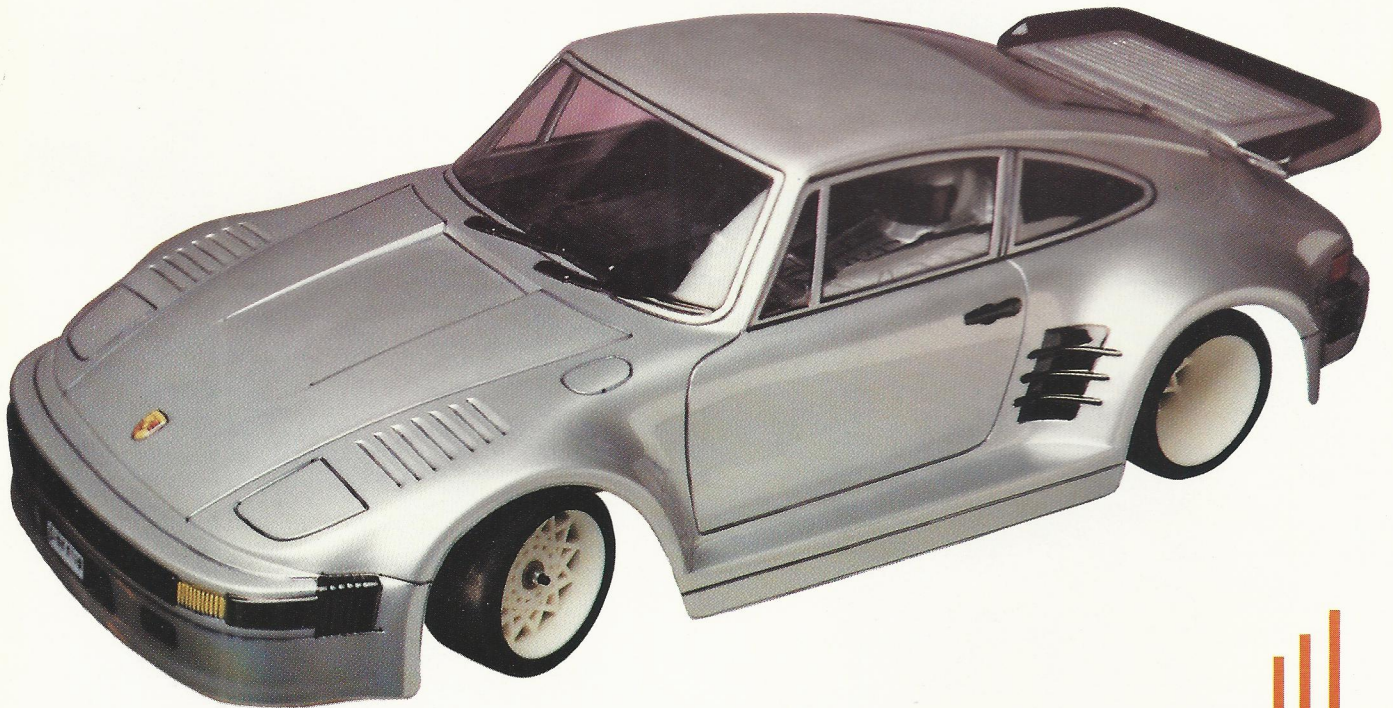

#10307 \$19.00

A brand new addition to Parma's extensive line of lexan body shells is the Porsche 911 Slant Nose. Molded in crystal clear lexan, this 1/10 scale reproduction has beautiful detail and comes complete with wing.



13927SA Progress Parkway, North Royalton, Ohio 44133

LOOK FOR PARMA AT THE RCHTA SHOW

Parma regrets we cannot supply individual orders on a retail basis.

For parts and information, contact your local Parma dealer.

SEND \$2.00 FOR A FULL COLOR CATALOG.

Steer clear

The Clod Buster. The monster 4-wheel drive, 4-WHEEL STEERING R/C pickup from MRC-Tamiya.

The first thing that catches your eye are those mammoth tires. Any R/C truck that sits on tires nearly 6½" high will attract your attention.

But the second thing...the most exciting thing to hit R/C yet...is the steering system. Four wheel steering. And only Tamiya has the guts and foresight to bring this technology to you now.

Now, 4 x 4 x 4. 4-wheel drive...and 4-wheel steering

Never before could you get so many advanced features in one package. Like dual motors for turf-tearing power. Motors that can be switched to run in parallel for power climbing...or in a series for endurance driving. These motors are no babies, either. Our 540 type motors alone set records for speed and torque. So imagine harnessing two of these brutes together! Each motor powers a set of wheels shod with huge, crusher tires. So now you can run over even the largest obstacles, or crush

them in your dust. Add new excitement to your driving. Almost nothing will stand in your way.

4-wheel steering...a new direction in R/C

You might expect a huge truck like this to be a little clumsy in the tight spots, right? Wrong! The all new four wheel steering lets the Clod Buster navigate the narrowest ditches, squeeze around fallen trees, maneuver on just about any terrain... wet or dry.

Heavy duty suspension

We've complemented this sophisticated new steering system with a rugged link-style single trailing arm suspension, with rigid

axles both in front and rear. Then we damped it with not four but eight heavy duty coil spring shock units. If you like, upgrade them later to oil-filled units.

The Clod Buster's engineering uprights are also super heavy duty, measuring more than a full 1½" in diameter. Now that's tough.

See the 4-Wheel Steering Clod Buster at your hobby shop, now... and let the competition steer clear.



Model Rectifier Corporation
2500 Woodbridge Avenue
Edison, NJ 08817

(This is no illusion. It's an actual photo of the Clod Buster climbing over 1/10 scale off-road cars. Note the size difference.)

