

June, 1990



COMPETITION



PL

CAR MAGAZINE

1990 ROAR
4-CELL
NATIONALS

RC10
TRANSMISSIONS

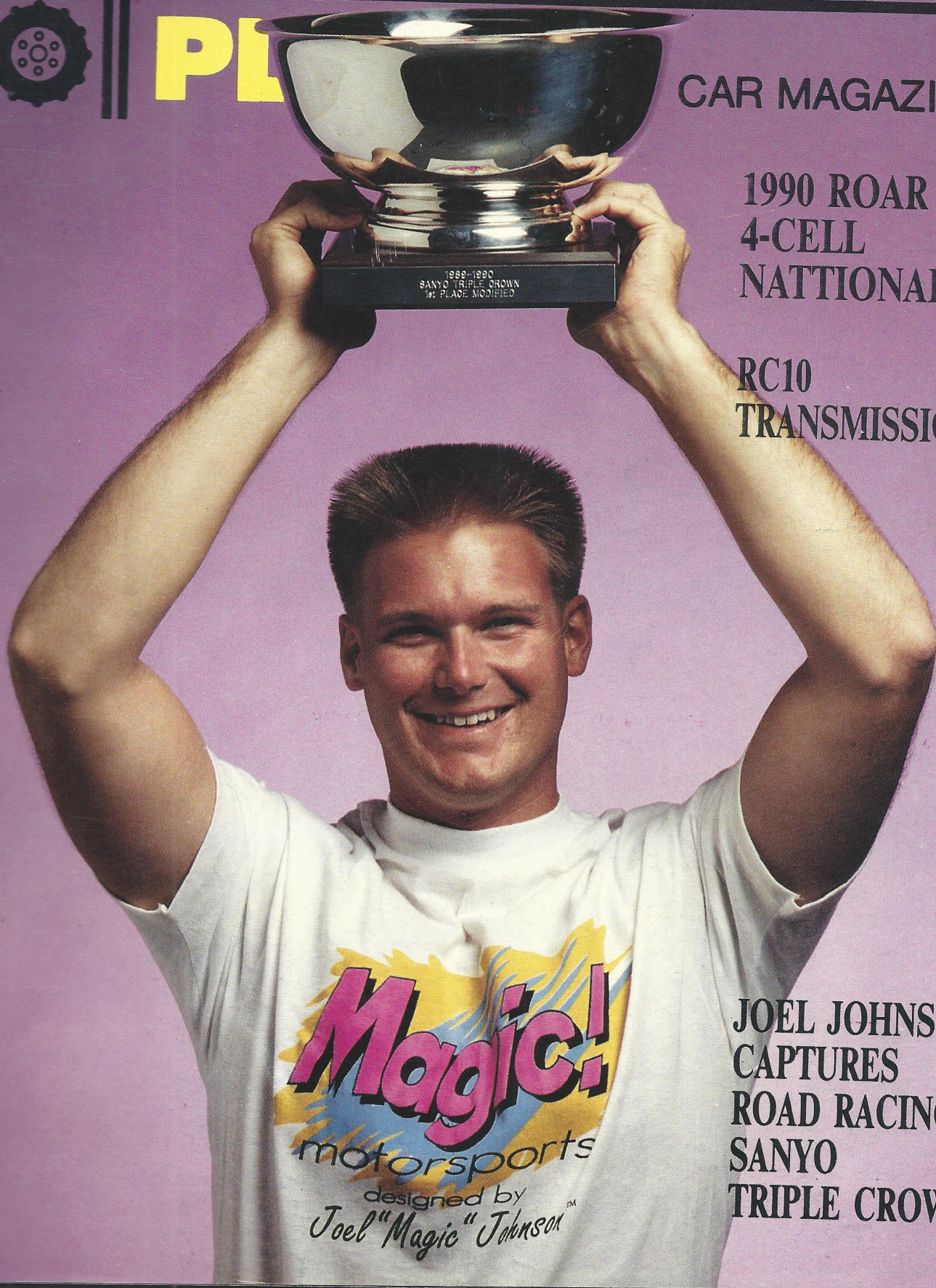

JOEL JOHNSON
CAPTURES
ROAD RACING'S
SANYO
TRIPLE CROWN

.049 GTP NISSAN

Radio Controlled 1/12 Scale On-Road Race Car

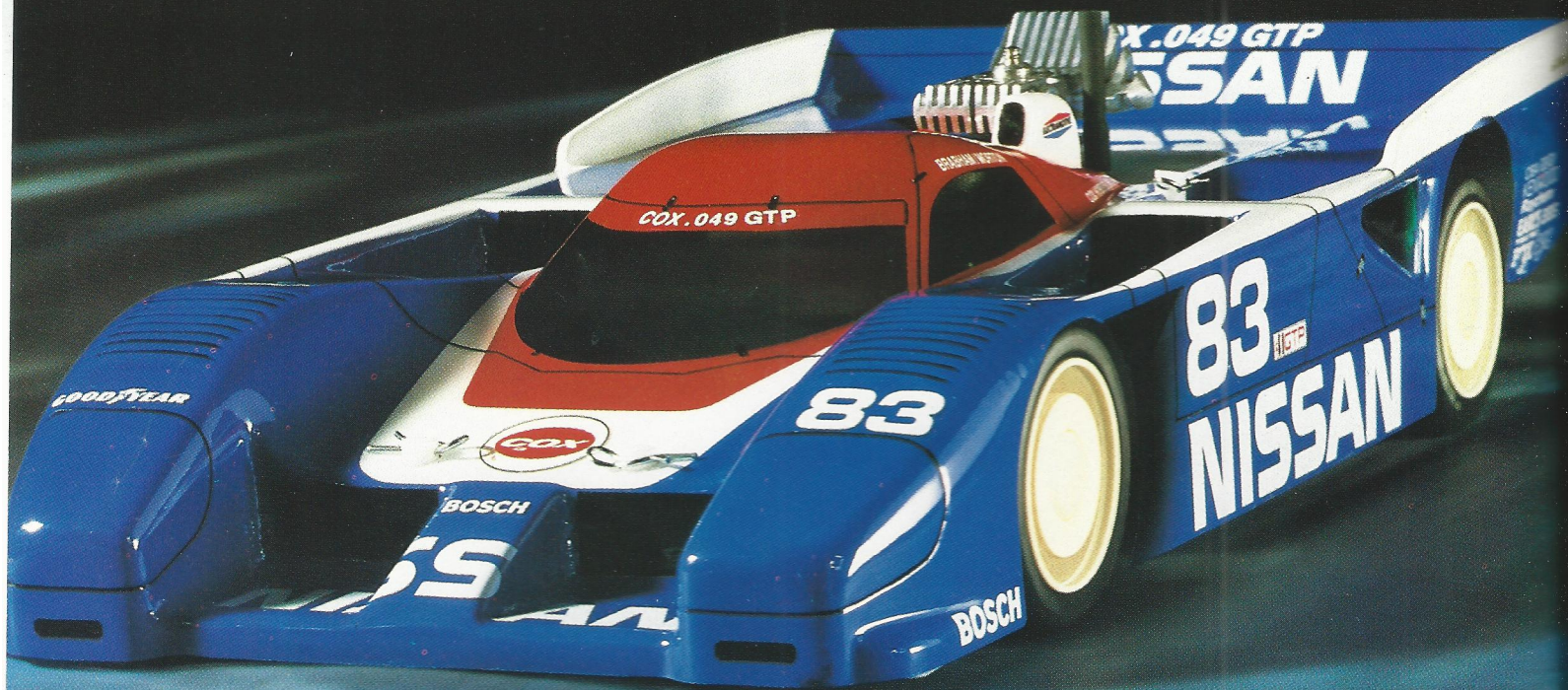

GAS* POWERED

* Use Cox Super Power Fuel Only

You're looking at the newest car to hit R/C racing.

The Cox .049 GTP Nissan.

It's powered by the world's finest small engine, the Cox .049.

There's nothing like it.

Running at peak performance, the incredible Cox .049 engine turns an awesome 23,000 RPM . . . That gives you the thrilling sound of full size racing.

Full out, the .049 GTP Nissan travels in excess of 30 MPH . . . That delivers the speed you need for exciting, competitive racing.

The .049 GTP Nissan combines the latest R/C racing technologies: minimal weight, fiberglass chassis, rear axle differential and independent coil front suspension . . . That enables you to corner the .049 GTP like it's riding on rails.

The engine burns Cox fuel . . . That produces the same smell of nitro you experience at full size race tracks.

Give your racing some gas.

Drive the new Cox .049 GTP Nissan.

You'll find it at your favorite race track or hobby shop.



350 West Rincon Street
Corona, CA 91720

STRIKE FIRST

with TRINITY BRUSHES

No matter what type of racing you do, there is a high horsepower, low friction, long wear Trinity Motor brush to suit your needs!

Trinity brushes are molded, not cut like cheap copies, which are prone to stress related breakage. These brushes are designed as replacements for all Trinity, Orion, Yokomo, Kyosho and Air Supply motors.

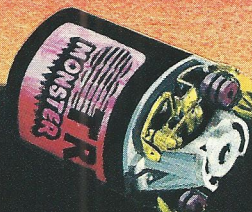

Slotted Dual Brush System

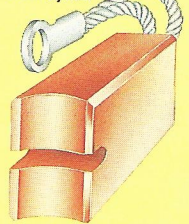

The first new brush designed for today's motors! Dual shunts for lowest resistance, new non-glazing formula. Slotted face for less arcing, less heat build-up and a more positive brush to commutator contact area. These are the only brushes that allow the hottest 8 thru 14 turn modified motors to produce maximum horsepower. **#4103 - \$3.50**

Contoured, Triple Cuts

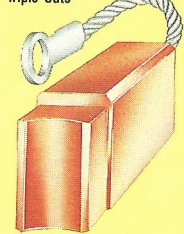

For 1/12 scale, on-road cars. Gives more torque and less arcing by maximizing the ratio of current draw vs friction on the commutator. For 14 to 20 turn motors. Speedworks 0007, 0012. **#4034**, soft compound for 4-cell **#4037**, for 6-cell **\$4.99**

Full Size Replacements

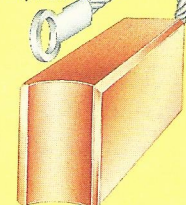

#4005, \$5.25 Soft compound comes in stock Trinity and Speedworks motors, w/springs. **#4038 \$3.00** Hard compound for longer life in off-road motors. In Trinity modifieds 1700 to 1704. **#4046 \$3.00** Soft compound produces higher rpms in stock and on-road motors. **#4065 \$1.99** Same as 4038 but without terminal.

Timed Brush

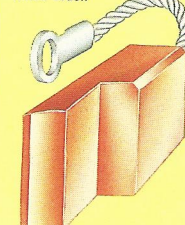

Shape increases timing and RPM's in stock motors. These work so well they should be illegal! For Trinity 2000, 2020, Speedworks 0004, 0005, 0444 and all Yokomo and Kyosho stock motors. **#4007 - \$4.79**

Cut Brush

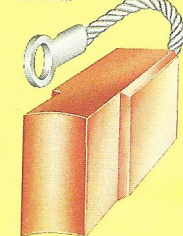

The narrow face increases RPMs, reduces arcing. Designed for oval racing or motors with lots of timing advance. **#4006 - \$4.79**

Off-Road, Cut Brush

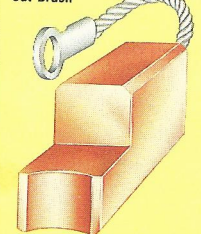

For on and off-road motors with 14 turns and more. Less friction on commutator gives higher rpm's and more torque. Hard compound for longer life. Used in Trinity 1705 thru 1711 and Speedworks 0001, 0002, 0003, 0008, 0009 & 0555. **#4035 - \$4.79**

TRINITY Trinity Products, Inc.

1901 E. Linden Ave., #8, Linden, NJ 07036 • (201) 862-1705 • FAX: 201-862-6875



The Only Difference Between The Motors In These Two Cars Is 318 lbs. & \$59,920.47

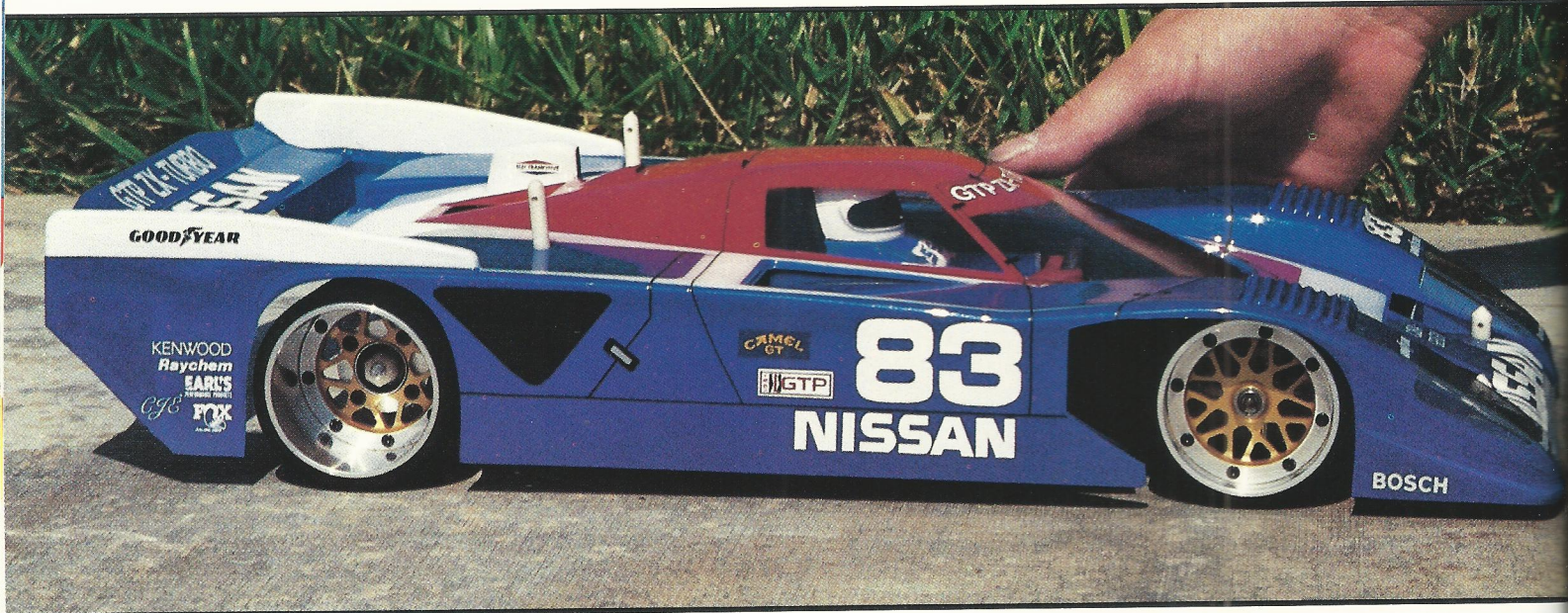

Well, maybe we're stretching the point a little bit here. The point you should remember is that Peak Performance builds their motors with the same kind of skill and high-technology thinking as "the big boys."

Because winning is the goal of every motor car enthusiast.

From our top quality stock motors to our twelve turn "BEAST" (our high-performance champion), Peak Performance is dedicated to building durability, speed and reliability into all our R/C car motors.

So if you're just as serious about your racing as we are, check out the full line of Peak Performance motors at your local hobby dealer today.

- 1986 & 1987 1/12th Scale Nat'l Champs
- 1988 1/10th Scale West German Champs
- 1988 & 1989 1/10th Scale Dirt Oval Nat'l Champs
- 1989 1/10th Scale On-Road Nat'l Champs
- 1989 1/10th Scale Australian Nat'l Champs
- 1989 1/12th Scale Swiss Nat'l Champs
- 1989 1/10th Scale Danish Champs

PEAK PERFORMANCE

1362 East Edinger, Building B • Santa Ana, CA 92705 USA
PHONE: 714-667-6865 FAX: 714-667-0858



COMPETITION



PLUS

DEPARTMENTS

6 MAILBOX
Letters and Comments From Our Readers

8 FINISH THE LAP YOU'RE ON
Editorial Comments

19 PIT BOARD
Late Breaking News

88 RACING TIPS
General Helpful Tips

89 RACING SCHEDULE
*Listings of Race Locations and Dates From
Around the Country*

97 NEW PRODUCTS
*What's New and Hot in the R/C
Car Market*

100 ADVERTISER'S DIRECTORY

COLUMNS

11 HARD CHARGING
ROAR News

15 STRAIGHT LINE FEVER
IEDA News

FEATURES

Page 17

NEWSLINE

*Tekin's Mickey Thompson Off-Road Grand Prix
The Big One
SARCAR Does the Pullyallop*

Page 27

COME TO THE . . . OASIS HOBBY PARK
A Look at their Inaugural Race & Facility

Page 38

1990 ROAR 4-CELL NATIONALS
*Hohwart win the Nationals &
Joel Johnson picks up the Triple Crown*

Page 55

1990 FESTIVAL OF RACING WINTER CHAMPS
The exciting second leg of the Triple Crown

Page 67

RC10 TRANSMISSIONS
A review of several RC10 Transmissions

About The Cover

This month's cover features Joel Johnson from Team Trinity displaying his Sanyo Triple Crown trophy.

MAILBOX

MOTOR & BATTERY COMMON SENSE

Dear Mr. Barana:

Prior to commenting on anything, let me say that I am a local racer who runs strictly off-road. If any comments I make in this letter are out of line for either on-road or oval racing. Please allow me to apologize for my ignorance. However, in the off-road section, I feel it is time for the whining to stop. I'm specifically talking about the complaints regarding stock motors, seven cell batteries, and SCE cells.

As far as stock motors go. I must ask, "What's the problem?". The stock motors that I am running are the "new" breed of high timing advanced cans, and I've really been nothing but pleased

with them. Given proper treatment, these motors will last as long as the low timed motors of old. My #1 motor is based on the Trinity can and is presently eight months olds and healthy. During those eight months, it has been raced twice a week, every week. (Totaled up, that is darn near 200 4 minutes runs). While not every run was a first place victory, the majority of them were A Main runs. While this is mainly on a local basis, the "Locals" I race with are some of the most impressive in the region. Some have gone on to top place finishes in national events, and one went to the worlds. Most of them have had the same success with the motors that I have had.

There really is no secret to this longevity. It really just comes down to common sense and care. Two things motors hate: dirt and heat. Run with some form of breathable motor cover, and clean out what doesn't get blocked out. But do it after every run, not just the third Tuesday of every month. Research and find what a reasonable gear ratio is. Ask the fast guys at the track what they're running, but don't get locked strictly in to one opinion. Try a few different ones, but make them all reasonable, so as to combat the "killer" heat build-up. Make sure the entire driveline is bind free. The less torque required to turn a transmission, the less strain on the motor. The less strain on the motor, the less heat build up. Yes, keeping a stocker running requires dedication, time, and money. The cleaners required to dispel carbon build up on the comm do cost, but not what a new motor every weekend will. Like I said, a little common sense and care.

On to the subject of the seven

cell packs. Again - "What's the problem?" If we're talking seven cells, we must be talking modified. In modified racing, there should be as few limitations imposed as possible. Seven cells is a good limitation. The evil "Haves" should not be limited by the "Have-Nots". When it comes to seven cells, I'm in the "have-Not" half, and darn happy about it. I like running my six cell SRCs against seven cell SCEs. There really is something special about going in and fighting as the power underdog. Yes, most of the time I get beat. But I have yet to be beaten by someone else's batteries, be it six or seven cells. I've simply been out-driven. If someone takes the time to hone not only their driving skills, but also their chassis to the point of perfection while using seven cells, they are to be commended, not limited. If someone can beat you with seven, they can whip you with six. And if they are willing to put out the time, effort, and money required to run seven cells, run 'em. But don't be afraid to run with them, even if you only have six. You've actually got some advantages going for you. Less fear of dumping due to the lower amperage draw, for one. (Contrary to popular opinion). Generally, because of the softer kick (compared to sevens) you also have a traction advantage. All the horsepower in the world will not be effective until it sticks to the ground, especially in the corners, where all but the best are tail-happy fools.

In closing, I think simple information trading can be the great solution to some of the racers complaints. Organizations such as ROAR and NORRCA should provide new members

(Continued on Page 86)

THE WORLD'S BEST BATTERIES

**WON'T WIN
IF YOU CAN'T DRIVE!**

*Why waste your
valuable time testing
batteries, when you
should be practicing!*

Let the Battery Experts at STAGE III take care of your cell matching needs. They have processed and conditioned over 150,000 serious racing cells in the past 2 years!!

*You don't have to be a
"STAR" to get great service,
so call or write STAGE III
"The Ultimate Cell Test"*

STAGE III (313) 585-1150
1189 Chicago Rd., Troy, MI 48083

TEKINTM

ELECTRONICS, INC.

PEAK DETECTION

BATTERY CHARGERS

World's First - We Invented Them

All Tekin[®] Chargers Feature

- Small size 4"x4"x2" - Easy to take to track.
- Adjustable current for use with all cells.
- Use with 4-7 cells, 8 cells with strong supply.
- Plug in jacks allow you to use an inexpensive external voltmeter to monitor volts and amps if desired.
- Designed, engineered and made in the USA to give years of dependable use.
- 10 amps output for the highest, strongest peak especially with SCR cells.
- New molded slant case is rugged and very compact.
- Use with SCR, SCE, SC & other type cells. 50-4000 mah.
- Protected against overloads and shorts.
- Current adjust knob is easy to set, but won't get bumped.
- Use on 12v battery or most 12v automobile battery chargers or a power supply.
- At dealers everywhere.
- 120 day warranty.

BC210 PEAK CHARGER WITH REFLEX CIRCUIT

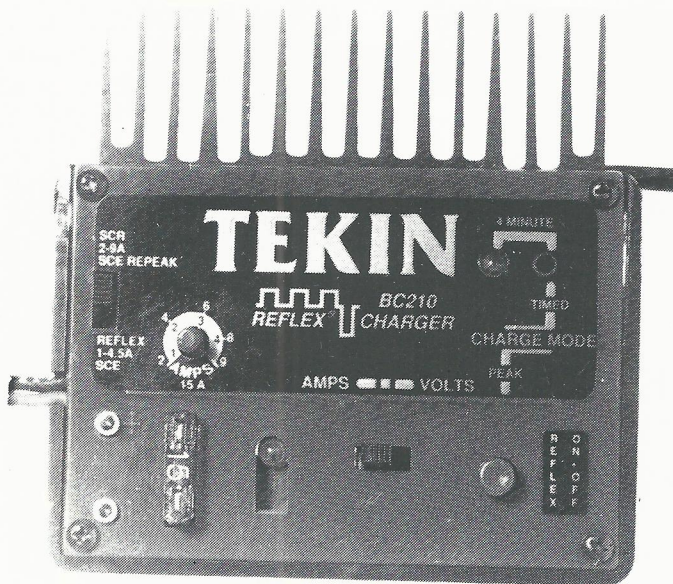

Reflex Charger uses negative pulses to recondition worn cells, partially restoring power and run time. Allows recharging the same pack all day without damaging cells, and with minimum loss of performance. Time Charge Mode to warm the cells up before racing.
#BC 210.....\$210.00

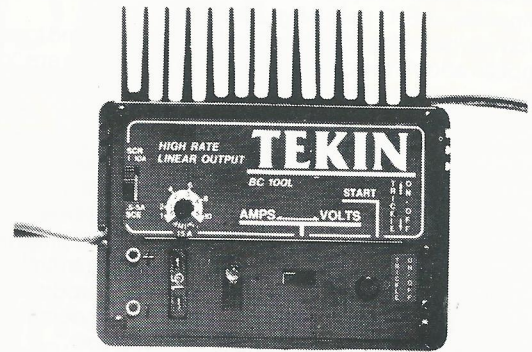

BC100L LINEAR OUTPUT

- 5 amp linear output, goes to 10 amps pulsed
 - Goes down to ½ amp to charge 50 mah receiver packs
 - Goes up to ten amps for the highest peak
 - Trickle on/off switch
 - Trickle is linear or pulsed, switch selectable
 - Also works off a 12v automobile battery charger as a power supply. Few, if any, other peak chargers do.
- #BC100L.....\$110.00**

Also available:

- **BC100**
- 1-9 amp pulsed output for SCR's \$102.00
- **BC870**
- 1-4.5 amp soft pulse output 80.00

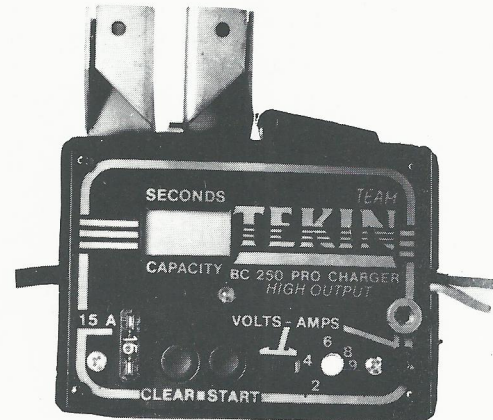

BC250S HIGH OUTPUT PRO CHARGER

Tekin professional model peak detector with LCD digital charge capacity indicator. Measures actual charge going into the battery pack in order to estimate battery capacity and run time. Reduces guesswork on battery condition. Calibrated to read in seconds of run time (based on 10 amps), the same as Tekin[®] Dischargers. Knob adjusts output current from 1-9 amps for the absolutely strongest peak and maximum power possible, especially with SCR cells. Use on 4 to 8 cells, 250-2000 mah. Tempfet overheat protection circuit built in. Double deck PC board for compact size. Volts/amps output jacks. Attractive multi-colored packaging.
#BC250S.....\$190.00

NOW WITH SOFT PULSE CIRCUIT

IFMAR WORLD CHAMPIONS

Finish the Lap You're On . . .

From time to time I think we've all heard racers say something to the effect that the manufacturers are going to ruin the sport. Whether it is in regards to the amount of sponsored drivers or the prices, inevitably that line will be uttered by someone. Especially common is that line around this time of the year when so much of our heavy racing occurs.

While I can't speak for all of the companies in R/C, I will say that the vast majority have the sports best interest in mind. I mean when you really think about it, who has the most invested in this sport. Your investment as a hobbyist may reach one, maybe two thousand. If you are a hard core racer, maybe five or six thousand. Now stop and think what some of the major companies in R/C cars have invested.

You can be certain they want this sport to be around for a long time. So why do so many people complain about "the problems" the manufactures are "creating"? You can dismiss a certain percentage of complaints to those who chronically complain about everything, but there's a lot more to it.

If any credence can be given to the opening statement of how the manufactures are hurting our sport it will pertain to the new and very small companies just starting up today. In an attempt to try and acquire some sort of market they are the ones who must come up with something new. Something that may be a bit better than what the rest have. Doing this; creating something a bit better is no hard task if price is no object. Herein lies the problem. Price is, and always should be a concern. The truth is, and its been like this for some time now, the small mom and pop companies can produce small runs of a product and charge a high price for it to justify production. The major companies in our sport today must produce thousands of units to keep prices relatively low.

Now I don't want to sound like we should discourage new companies. After all new companies need to advertise their product and that's where we come in. Maybe we should develop some guidelines as to when certain key products should be legal.

I'm speaking about some guidelines similar to those we have now on electric motors. You know, so many pieces have to be out to ensure good distribution and give racers all over the country the chance to buy the motor.

Again this might be something to adopt on key parts. Things like shock towers and nylon wing nuts are not really key parts. I'm talking about parts like tires and speed controls. Objects where if there were only a few available, for a select few, the outcome might be determined without even running the main.

Like many ideas illustrated on this page in the past, this proposal was brought to my attention by a fellow racer.

As always I look forward to what you've got to say on this idea.

Keep Having Fun!

PETER BARANA

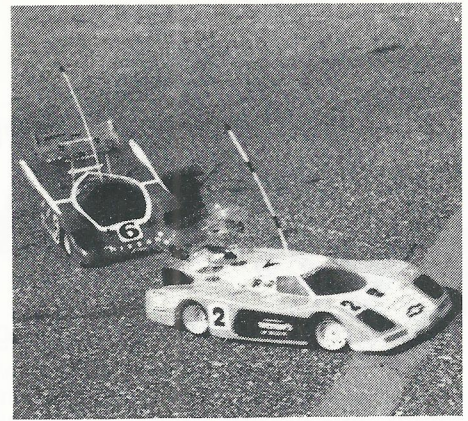

COMPETITION PLUS

16582 Gothard St., Unit Q

Huntington Beach, CA 92647

PHONE: (714) 846-0403 - (714) 842-3881

NEW FAX: (714) 848-2969

If you would like to carry CP in your store please call (800) 558-1544.

Except Wisconsin and Canada, then call collect at (414) 796-8776. Dealer inquiries only.

PUBLISHER

Cory Barana

MANAGING EDITOR

Peter Barana

MOTORSPORTS EDITOR

Bob Crane

INTERNATIONAL EDITOR

Mike Reedy

MOTOR EDITOR

Ernie Provetti

PRODUCT REVIEW

F. Dale Cauthen

Jeff Palmer

Kevin Gray

ADVERTISING DIRECTOR

Lisa Powers

Samantha Ryan

PARTS AIN'T PARTS.

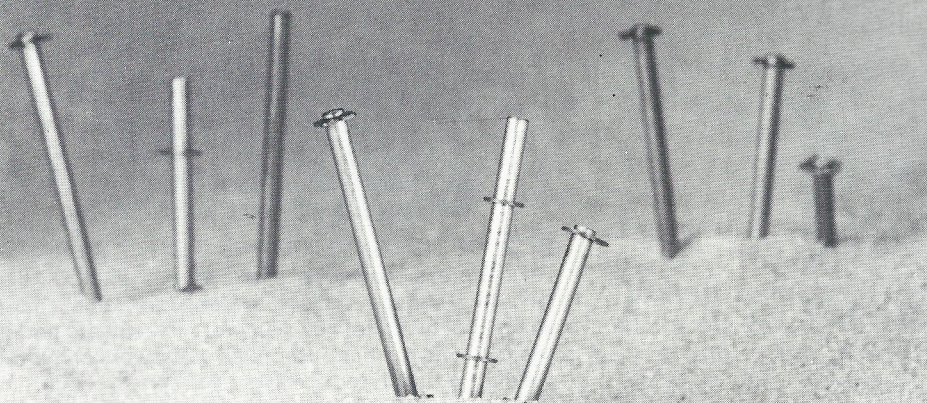

We've got the parts honed to win. Like our race-developed Titanium Hinge Pins. Half the mass of steel, they're the latest RC weight-loss program. Or our Steel Retaining Rings. Together, they're bullet-proof protection for RC10, YZ10, JRX2, Ultima and Optima Mid. RC Performance Specialties. Call us for the parts that are serious about winning.

Wholesale Only
RC Performance Specialties
18312 Gifford St., Fountain Valley, CA 92708

TEL 714/962-6928
FAX 714/962-4089



Competition Plus welcomes unsolicited manuscripts and photos, but cannot be held responsible for return. However, publisher reserves the right to condense, add and edit all copy submitted according to available space and editorial style. The act of mailing material shall constitute an expressed warranty by the contributor that the material is original and in no way an infringement upon the rights of others.

Entire contents copyrighted, 1990 by Barana Publishing Company. All rights reserved. Reproduction in all or part without written permission is strictly prohibited.

Competition Plus allows its columnists the fullest expression in discussing controversial subjects, so its readers will be better informed. The views expressed may not necessarily agree with those of the magazine.

SUBSCRIBE TO COMPETITION PLUS:
\$22.95 a year third class - \$32.95 a year first class; Canada \$32.95 First Class only; Foreign Countries \$35.00 surface - \$55.00 First Class. Send Check to **COMPETITION PLUS**, 16582 Gothard Street, Unit Q, Huntington Beach, CA 92647. Send name and address including zip code with accompanying check. All foreign subscriptions are in US dollars.

THESE MONSTERS ARE KILLERS!



NEW! #2020 "Reverse Rotation Monster Stock" 4, 6 or 7 Cell, Brutal 24,200 RPMs. For Dual Motor Monster Trucks like the Glad-Buster, Double Dare etc. Totally Outrageous in cars using Hyper Drive.

#2000 "Monster Stock" 4, 6 or 7 Cell, 24,200 Awesome RPMs

You'll be the "Killer" at the track after bolting one of these Monsters in your car.

If ROAR stock class is your bag and you strive to be totally awesome, then you need the most radical, mind-blowing motors around, and here they are: The Trinity Monster Horsepower Stock Motors. Score some in normal or reverse rotation, and you'll be totally prepped to shut down the competition and send 'em home. So, if you really want to be bad, then loose the nerd valley motors and get it on with Trinity Monster Horsepower!

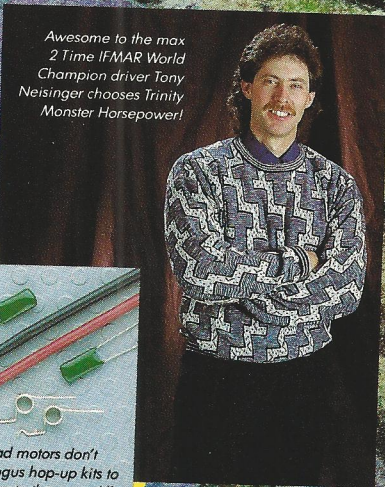

Awsome to the max 2 Time IFMAR World Champion driver Tony Neisinger chooses Trinity Monster Horsepower!

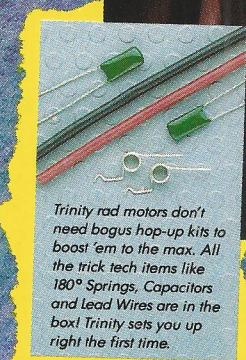

Trinity rad motors don't need bogus hop-up kits to boost 'em to the max. All the trick tech items like 180° Springs, Capacitors and Lead Wires are in the box! Trinity sets you up right the first time.

speedworks



The Speedworks Era is here!

Speedworks™ THE ONLY SERIES RESEARCH AND DEVELOPED BY TRINITY PRODUCTS INC.
DIRT OVAL STOCK MOTOR

Speedworks™ THE ONLY SERIES RESEARCH AND DEVELOPED BY TRINITY PRODUCTS INC.
SUPER SPEEDWAY STOCK MOTOR

Trinity Speedworks motors are a totally awesome blend of power, durability, economy and style. Plus they're the fastest, most bitchin' stock motors money can buy anywhere!

TRINITY

WORLD CHAMPIONS

TRINITY PRODUCTS INC.
1901 E. Linden Ave., #8, Linden, NJ 07036 • (201) 862-1705 • FAX (201) 862-5875

MONSTER AND MONSTER HORSEPOWER ARE REGISTERED TRADEMARKS OF TRINITY PRODUCTS INC.
© 1985 TRINITY PRODUCTS INCORPORATED



3025
ELAN "OFF ROAD" - MID OPTIMA



3240
1/10th SCALE "OFF ROAD" WING

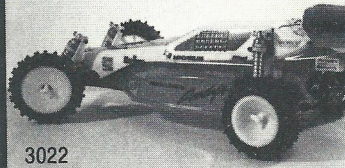

3022
HEATHEN "OFF ROAD"

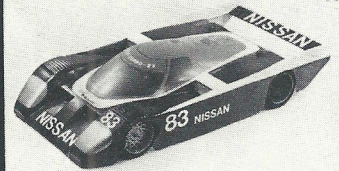

3145
NISSAN GTP



3418
RC-10 REAR BODY MOUNT

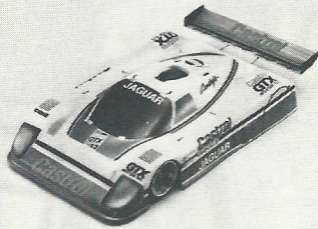

3141 - 4141*
89' JAGUAR GTP

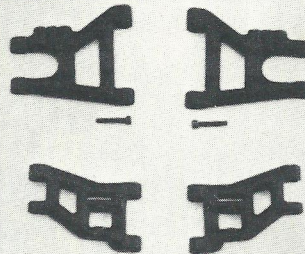

ANDY'S FRONT & REAR ARMS

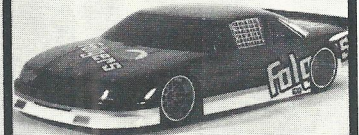

3162 - 4162*
89' CHEVY LUMINA - NASCAR

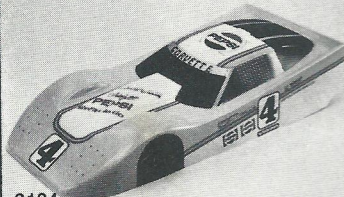

3134
1988 VETTE OUTLAW WEDGE

Andy's

R/C PRODUCTS
COMPLETE CATALOGUE \$2.00

Gotcha Covered

RACE PROVEN PRODUCTS

Body Chassis Parts

1/10 Scale Bodies

* 1/12 Scale Bodies

466 W. Arrow Hwy. • San Dimas, CA 91773 • (714) 592-4737 FAX (714) 592-0505
Made in U.S.A.



3420
MONSTER TRUCK FRONT BODY MT.



3412 RC-10 - 3512 ULTIMA
FRONT BUMPER MOUNT "OVAL"



3030
JEEP COMANCHE TRUCK BODY



3026
APACHE WARRIOR - YOKOMO

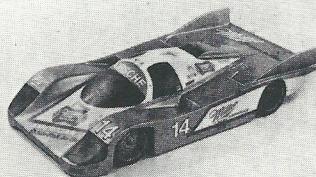

3140
PORSCHE 962 GTP

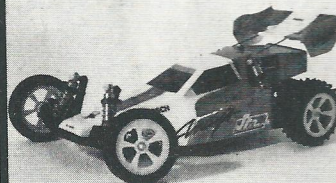

3023
HALF-BREED "OFF ROAD"



3414 - 3416
RC-10 "OFF ROAD" FRONT BUMPERS



3020 - 3021 - 3024
RENEGADE "OFF ROAD" SERIES

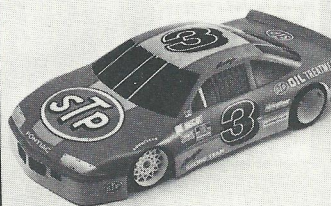

3160 - 4160*
89' PONTIAC GRAND PRIX - NASCAR

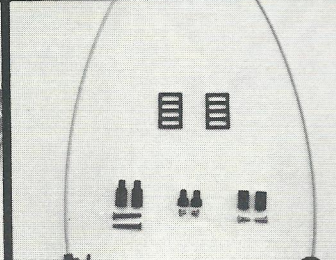

BODY PARTS & ACCESSORIES



3142 - 4142*
TOJ "ON ROAD" BODY

HARD CHARGING

By John Thawley

The long awaited for 1990/91 ROAR Rule Books are now just days away from delivery. While everyone agrees they have been a long time in coming, I think once you see them you will understand why. It is not that there have been a lot of changes in the technical rules or specifications. The big change is the book's format.

This type of project, when done correctly, requires a lot of thought. First, it must be "user friendly". It must be clear, accurate, and concise. Costs must certainly be considered. Not just production cost, but also cost of mailing and handling and cost of future updating. Believe me, this is no easy task.

But that is all behind us. I hope when you see the new books you will be just as pleased and as proud as we are. I would like to be sure to thank all the people who have helped review the different sections and scale specifications. Those are difficult areas that could just as easily been blown over. But these folks cared enough to see it done right.

Thanks goes to Marie Barana at Budlee Printing for the typesetting, layout and printing. We also want to be sure and thank Eric Meyers of Horizon Hobbies for providing the cover art. I think it looks real good! In fact, we are going to make this art available for trackside banners real soon.

Most importantly we need to thank ROAR President, Eric Gudger. This rule book is his baby. Eric has spent endless hours keyboarding, organizing, structuring, and reviewing every word of this book. He has hand carried it every step of the way. He has made it happen. Nice job Eric!

I would like to clear up some of the rumors that have been circulating in advance of the rule book's arrival. First, let me state, in the Modified Off-Road divisions ROAR HAS NOT gone to a six cell limit.

Also in the Off-Road division wheel size has not been increased to 2.2 inches. The 2.2 inch rims currently available are not and

RACERS *Now available 'Graphite Reinforced Axles' that give your car*

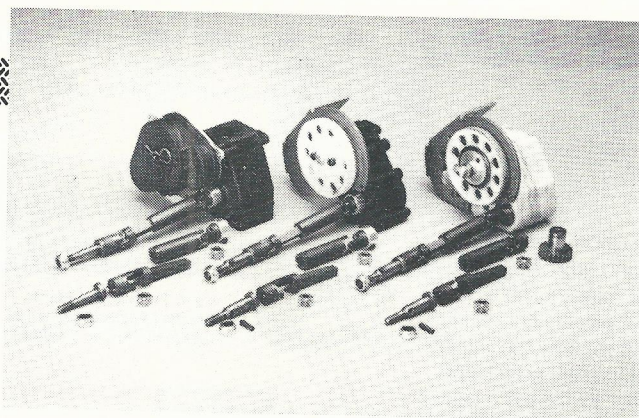

THE EDGE

For.....

*J-Cars, Modified Monster Trucks,
RC-10 & Ultima Racers...
... if you're using Kyosho, MIP,
Associated or Thorp Differentials*

Pavement or Dirt, On-road or off-road, Stock or Modified

*Quiet operation • Reduce drive line wind up • Very light weight • Small 3/8" diameter
Hardened steel stub axles • Available in Nylatron or Graphite*



Custom Scale Components

For more information call: (708) 305-9655 after 5 pm central

or write to: 1807 S. Washington • Suite 363 Naperville, IL 60565





1982-83 IFMAR WORLD CHAMPION/KENT CLAUSEN/RC12i/REEDY



1984-85 IFMAR WORLD CHAMPION/TONY NEISINGER/RC12i/REEDY



1986-87 IFMAR WORLD CHAMPION/TONY NEISINGER/RC12L/REEDY



1988-89 IFMAR WORLD CHAMPION/MASAMI HIROSAKA/RC12L/REEDY

CLEAN SWEEP OF THE EIGHTIES.



A WINNING TRADITION

One team, Team Associated, has won at every World Championship for 1:12 scale cars in the 80's. A clean sweep against the toughest competition anywhere.

And in 1988 the Team sweeps the top three places in the A main for the second consecutive time! In fact, Associated RC 12L's finished first, second, third and fourth in the IFMAR World Championships in Holland. You might say it was a real Baarn Burner of a race.

When the Team goes racing, we go racing to win. That's why top racers all over the world win with Associated cars. They know they have the edge with the only team to win seven IFMAR World titles.

THE POWER TO WIN

World Class drivers know it takes more than a great

1988-89 IFMAR WORLD CHAMPIONSHIPS/BAARN, HOLLAND			
First	Masami Hirose	Japan	RC12L/Reedy
Second	Tony Neisinger	USA	RC12L/Reedy
Third	Christian Keil	West Germany	RC12L/Reedy
Fourth	Kent Clausen	USA	RC12L/Reedy

car to win the World Championship. It takes great motors and great batteries, too. That's why Mike Reedy's motor lab is the nerve center for electric car racing at Associated. And that's why the Team depends on Reedy Matched packs and Reedy Modified motor for the extra power needed to win.

Take a tip from the pros and go racing with the Team. Team Associated. Model Cars for Real Racers.

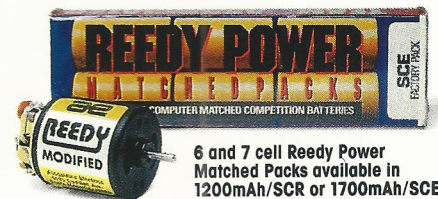

6 and 7 cell Reedy Power Matched Packs available in 1200mAh/SCR or 1700mAh/SCE



Associated Electrics
3585 Cadillac Avenue
Costa Mesa, CA 92626



Masami Hirose (center), Tony Neisinger (left) and Christian Keil (right) led a united nations sweep of the 1988-9 World Championships.

will not be legal at ROAR sanctioned events. The new wheel rule will be as follows:

Wheel Sizes - 1.625" maximum bead mounting diameter. 2.150" maximum bead mounting diameter. Bead mounting dimensions are measured at the point where the internal tire bead meets the wheel.

2.350" maximum wheel diameter. Internal locking ring may be used for the purpose of retaining the tire only. Ring can not be used to increase the wheel's original size and/or the stiffness of the tire sidewall.

1.500" maximum width.

Tire Size - 1.75" maximum width. No minimum tire diameter. 3.544" (90 mm) maximum tire diameter.

Another addition to the rules will be the new Monster Truck class. I know I receive a lot of calls at the ROAR office for this class so I'm going to reprint those rules here. This should help a lot of clubs get started right away.

Good luck!

1/10 MONSTER TRUCK RULES

Track Widths - Continuous eight (8) feet minimum.

Wheel Sizes - 2.175" minimum bead mounting diameter. 2.250" maximum bead mounting diameter. Bead mounting dimensions are measured at the point where the internal tire bead meets the wheel.

2.425" maximum wheel diameter. Internal locking bead may be used for the purpose of retaining the tire only. Ring can not be used to increase the wheel's original size and/or the stiffness of the tire sidewall.

2.000" maximum width.

Tire Size - 2.125" maximum width. 3.6" minimum tire diameter. (measured by the carcass)

Wheel Base - 11 1/2" maximum. 9" minimum.

Width - 13" maximum.

Overall length - 18" maximum.

Batteries - Stock: 6 cell. Modified: 7 cell.

Weight - 2 Wheel Drive: 3 3/4 pounds minimum. 4 Wheel drive: 4 pounds minimum.

Race lengths - Four (4) minutes.

BODIES

All bodies must resemble race type truck bodies. Maximum rear spoiler chord of two (2) inches. No side dams or wings.



Don't Make A Move Without Us!

Subscriber: Please notify us of your new mailing address four weeks prior to moving.

Name _____

Address _____

City _____

It's as simple as 1 - 2 - 3!

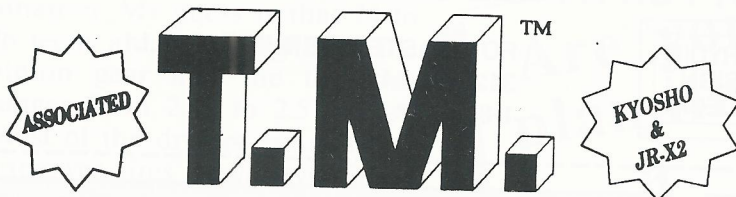

R/C RACING COMPONENTS
NEW
VALVE-A-MATIC'S!![®]

Eliminate problems with your off road car bouncing off bumps or when landing off jumps. Smooth out those hard to handle rough tracks, and make your car or truck handle like the real off roaders!

With VALVE-A-MATIC'S, your shocks will work like shocks were meant to work! All you need to do is replace your stock pistons with the new VALVE-A-MATIC (2) piece pistons. VALVE-A-MATIC'S will work on front and rear shocks (Short, Medium, or Long) stroke, and are available for Associated, Kyosho and JR - X2 shocks.

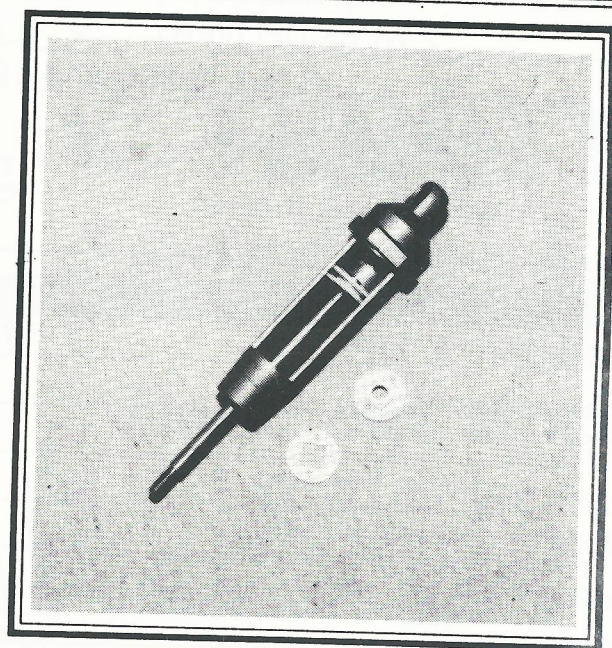

T.M. R/C RACING COMPONENTS • 49679 LEONA • MT. CLEMENS, MI 48044 • (313) 949-3506 • FAX: (313) 949-3506



RYDIN R/C RACING NUMBER SETS®

YOUR NAME PRINTED ON EACH NUMBER

3¢ PER NUMBER

1,000 DIE CUT 1 THRU 8 NUMBER SHEETS FOR \$240.00
(ACTUAL SIZE SHOWN ABOVE)

SATISFACTION GUARANTEED OR YOUR MONEY BACK.

2 WEEK DELIVERY • ALL ORDERS SHIPPED UPS — C.O.D.

CALL 1-800-448-1991 FOR A FREE SAMPLE

RYDIN SIGN & DECAL
660 POND DRIVE
WOOD DALE, IL 60191



FOR FASTER SERVICE, CALL!
312-766-8410
1-800-448-1991

MAILING ADDRESS

Company: _____
Street Address: _____
City: _____
State & Zip: _____
Phone: () Night Phone: ()
Contact Name: _____
Today's Date: _____

SHIPPING ADDRESS

Company: _____
Street Address: _____
(We cannot ship to a P.O. Box)
City: _____
State & Zip: _____
Attention: _____
Date Needed: _____

Quantity	Your Track Name	Total
<input type="checkbox"/> CHECK ENCLOSED RECEIVE FREE SHIPPING		
<input type="checkbox"/> SEND FREE SAMPLE		
Handling Charge per order		\$6.50
TOTAL		

STRAIGHT LINE FEVER

By Bob Boucher

MIKE HOUGE'S NATS WINNER

More details on Mike Houge's Nat's winner dragster. Mike sent us a photo of his nats winner. I tried to count the teeth on Mike's pinion gear and it appears that he was running a 24:93 gear ratio and about 2-3/8 inch tires. The Illusion was motivated by twenty Sanyo 600SCR cells and an Astro Top Fuel II motor. No this motor is not the size of a beer can it is slightly smaller in diameter than a Yokomo, but slightly longer. Mike had to remove a bit of plastic material from his pod and bore out his 24 tooth pinion gear to 5/32 inside diameter to fit the 5/32 motor shaft. Mike's best time at the Nats was 1.91 seconds, but he is reporting times in the low 1.8 seconds at a local Florida track. I don't know what the optimum tire size and gear ratio is for this motor/car combination. My guess is that 24 to 26 teeth are about right for the pinion gear and the tire size ranges from 2.25 to 2.5 inches. Most of the drivers are running narrower tires nowadays. Some are as narrow as one inch but most are about 1.5 inches wide.

ANOTHER FAST ILLUSION

Chuck Savoca of Boca Raton, Florida sent us a photo of his record breaking dragster. Chuck set a new IEDA Top Fuel speed record fo 76 mph on March 16 at the South Florida Fairgrounds in West Palm Beach, Florida. Like Mike, Chuck's Illusion is powered by twenty Sanyo 600 SCR cells and the powerful Astro Top Fuel II motor. The race was run by Sunshine R/C and timing was conducted using a certified

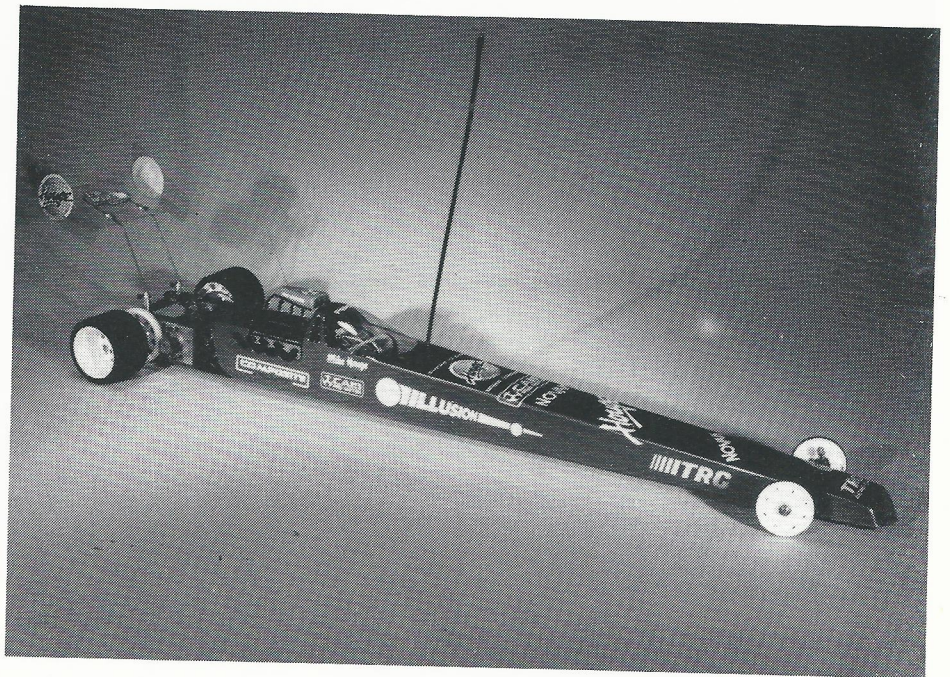

Mike Houge's Nats winning Illusion dragster.

Are you
planning

a

BIG

event?

TRINITY
Speedworks

new wave technology

**Hand out stock
motors**

If you are thinking about staging a major race, or simply need handout club motors, there is only one logical choice! The TRINITY™ and SPEEDWORKS™ stock motors are now available for your race.

Why settle for second best, when you can use the fastest most reliable motors on the market.

For pricing and more information just give us a call and ask for Tony P.

Trinity Products Inc. • 1901 E. Linden Ave.#8 • Linden, N.J. 07036
• (201) 862-1705 • Fax: (201) 862-6875

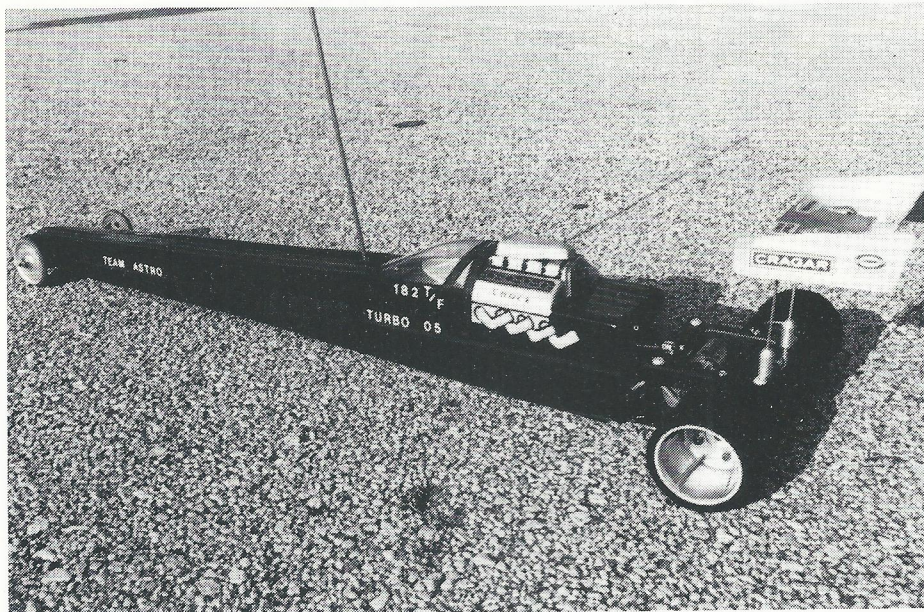

Chuck Savoca set a new IEDA Top Fuel record with this Illusion/Astro Top Fuel II combination.

chronodeck timing system. Sunshine R/C advises us that they hold drag races every Friday night. Time trials begin at 6:30 p.m. and eliminations begin at 9:00 p.m.

SUMMER NATS

Bob Purcell advises that the

Summer Nats previously scheduled for Mother's Day has been rescheduled to the first week in June. I guess there are more MOTHERS in drag racing than I thought. For details on the Summer Nats, contact Bob Pucell at (714) 684-6314.

THE POMONA SHOW

Both Novak and Astro showed

prototypes of their new speed control designed specially for drag racing. The new Novak control is very compact and uses two separate circuit boards with surface mount components. Externally the unit resembles the Novak T-1X but it has a number of differences. First the built-in BEC can handle 20 cells. And the brake circuit is a bit larger to handle the power required to stop a 20 cell top fuel dragster. This is Novak's first high rate controller. I don't know what the switching rate is but I would guess about 2000 hertz. A number of racers have been running prototypes at Drag World and report good results. Bob Novak says he expects to ship production units in early summer.

The Astro Model 205 Electronic Speed Control is also designed with drag racing in mind but it can handle up to 32 cells. Enough for 1/8 scale dragsters and twin 40 pulling trucks. The brake circuit is massive and uses FIVE FETS. This brake should be able to stop most anything. The ten FETS are riveted to an integral aluminum heat sink that measures 1.5 x 2.25 inches. The Astro control is also a high frequency switcher and runs at 2000 Hertz switching rate. Bob Boucher chose a different design philosophy and incorporated OPTO-COUPLING. This means that the radio has no physical connection to the motor circuit to minimize any possibility of radio noise. Radio noise sometimes causes stuttering that robs you of acceleration off the starting line. Since there is no physical connection between the motor battery and the receiver a small receiver battery is required. Most of the guys are using a five cell 60 ma battery that weighs about 1/2 ounce. Astro advises that the Model 205 should be available in early summer.

"HAVE IT YOUR WAY"



LETS YOU MAKE THE CHOICE, OVAL OR ROAD COURSE.
WE HAVE A CAR FOR YOUR STYLE OF RACING.

The L.T.O. was the first car SPECIFICALLY designed for Oval Racing.



1989 ROAR STOCK OVAL NATIONAL CHAMPION
BL-1377 Eliminator L.T.O. (Left Turn Only)

The LTO kit features graphite chassis, full ball bearings, kingpin brace, ball suspension kit, graphite axle, adjust-a-link, stabilizer bar, aluminum hubs, stock car wheels and tires, and it's topped off with a wind-tunnel tested stock car styled body.

The Gold Edition features graphite chassis and front axle plate, ball type rear suspension, kingpin brace, graphite axle with 5 ball bearings and aluminum rear hubs, "gold" rear blocks with adjustable axle height, "gold" aluminum chassis parts, adjust-a-link, special "gold" decals, and a stock car styled body.

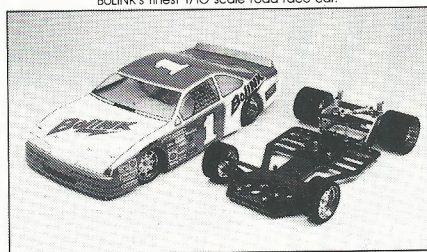

BoLINK's finest 1/10 scale road race car.

BL-1376 Eliminator Gold Edition



FOR COMPLETE INFO ON BoLINK's FULL LINE OF PRODUCTS, SEND \$3.00 TO:

R/C CARS, INC. (CP) 420 HOSEA ROAD / LAWRENCEVILLE, GA 30245
(404) 963-0252 / FAX: (404) 963-7334

NEWSLINE

MICKEY THOMPSON OFF-ROAD RACE

By Steve Saik

High-flying, car banging excitement! What else can I say when the Mickey Thompson race comes to town. NORRCA got in on the action by building an off-road RC track in the Anaheim Stadium parking lot and inviting members to participate in the action packed RC event on a treacherous track. 247 avid entrants filled up the eastern section of the stadium lot, ready for an RC shoot-out.

NORRCA created a challenging track in Anaheim for its competitors. Supported by boards on four sides, in the figure of a large square, the track was carefully laid out in the center with plenty of hairpin turns, rough straight-aways, whoopdeedo's, and large menacing jumps which really gave drivers something to contend with. Cars tumbled out of control until drivers became more experienced with the jumps, and soon racers were skillfully negotiating cars through obstacles at high RPM's.

Both local racers and drivers from out of town showed up to test their skills with the best. Many new RC cars were on the scene-JRX-T truck was one, which Team Losi's Phred Gebauer was expertly piloting. Ed Corea (announcer at Bob & Jim's, Riverside) was also driving well with the JRX-T, which he had just assembled that morning. New inventions and the latest in tires propelled many new tricked-out cars as they raced around the track. The hum of excitement was in the air; and all RC cars were ready for the challenge. Now it was a question of whose driving skills would prevail.

Before the qualifying, however, there was competition for the top

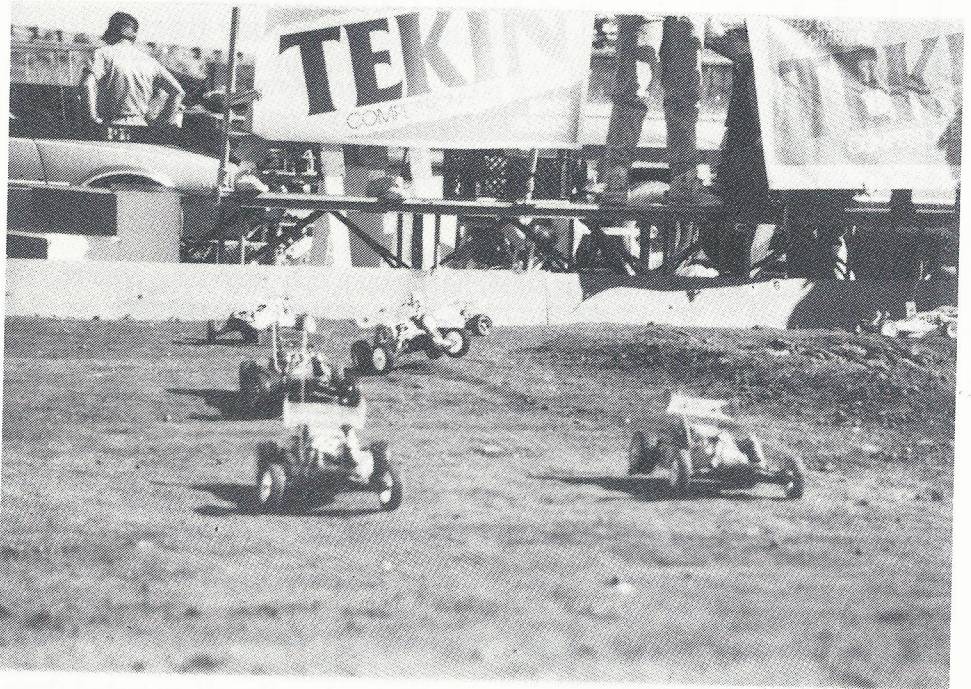

A good clean start of one of the 2WD Open qualifiers. Note: The portable driver's stand and the removable track barriers. NORRCA's crew built these tracks from the ground up. All this work for a one day race to help expose the sport to new areas that will help keep it growing.

three totally awesome looking car bodies. It was a close contest here, as the judges scrutinized each body, the trucks and

Leading Edge R/C Racing Products

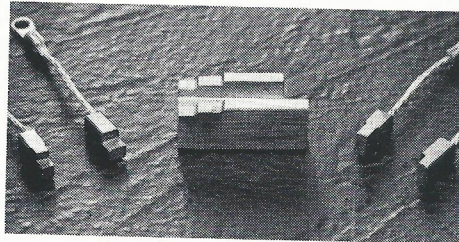

Now you can get the same cut as the PRO'S!
Without Paying \$1-2 for Cut Brushes
At Only \$14.95
This Tool Can Be Handy in Every Tool Box.
• AVAILABLE NOW •

NEW!! BRUSH CUTTING JIG NEW!!

See Your Local Dealer

• Dealer Inquiries Invited •

LEADING EDGE

3224 Fourth St. - Wyandotte, MI 48192 - (313) 282-3586

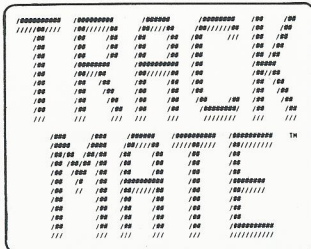

- Handcount and AMB Systems
- Frequency clear qualifiers
- Unlimited number of qualifiers
- Class Standings each round
- Sorts Mains between heats
- Immediate Point Standings
- Driver Ranking Feature
- Customized to your track

If you need a race management program, **TrackMate** can help. We are the experts in user friendly race management. This is **TrackMate's** fourth year and its glitch free operation guarantees you a successful race every time out. There is no other race management program available with the features offered by **TrackMate**.

TrackMate comes in three sizes to fit your track and budget. **TrackMate Jr.** is perfect for small, hand-count only tracks like Master Raceway while **TrackMate Pro** handles the regional and national event tracks like Lake Whippoorwill. Standard **TrackMate** is just right for all those mid-range tracks that either hand-count or use the AMB System. All three versions offer automatic race series points management for your drivers.

Call for our FREE Demo Disk

TrackMate Systems 508-435-6008

TrackMate is a trademark of TrackMate Systems

buggies were sporting some especially cool paint jobs, but Bob Kaufman with his JRX-T truck wowed everyone and was awarded First place. Jim Stevenson took second for his nicely painted Baja-Toyota truck, and Roger Tibbets won third for his JRX-2 buggy. Congratulations to all entrants - you all looked great!

QUALIFYING

Crammed with close, door-banging action, the qualifying (all 30 heats, if you can believe it!) was full of excitement from start to finish. Heat after heat of cars screaming around the track, each driver jockeying for the best angle to catapult himself into the top qualifying position. In the Super Stock Truck competition, Bill Ogden left the other racers a lap behind in his dust, as he pulled down a blistering 13/4:13.50. The 2WD Stock action was a battle for TQ between Gene Mason and John Schultz. Schultz pounded down the ponies to make him TQ at 13/4:08.93. Novice racing exhibited good

driving by all as they tested their new racing skills. It was Steve Taffert with 11/4:17.20 who qualified with the best Novice time of the day. Tony Maganuco jumped on top in the 4 wheel Stock at 12/4:07.20. In the 4 wheel Open Truck class, one of the fastest was J.B. Hunt (RevTech, Pro-line sponsored), who got out and flew with a 12/4:06.14, followed by a pack of drivers only scant seconds behind his dust trail. It was Chad Christians in 4 wheel Open who took the TQ honors at 12/4:04.49. The Open Monster Trucks did not stop for anything, and competition was fierce; and J.B. Hunt, driving with a vengeance, made the TQ seat with 12/14:00.80. In the 2WD Open class, John Schultz went 13 laps/4:18.36, a screaming fast time, to win his first qualifier.

As qualifying wound down, a sizable spectator crowd had accumulated as approximately 220-300 people gathered there in the parking lot to watch the start of the RC mains before they filtered into Anaheim Stadium to

see "the real thing" - the monsters, buggies, trucks, and off-road machines that would soon burst into action at the Mickey Thompson event inside the stadium. When not busy, numerous RC drivers took advantage of the opportunity to walk through the actual Mickey Thompson pits. Both our RC track and Anaheim Stadium's track buzzed with excitement and anticipation for the main events ahead.

THE MAINS

Driving was superb and competitors hungry for trophies as the racers in the 2 wheel Open A Main exploded from the starting line at the sound of the tone. John Schultz took the front spot, but Mike Dunlap capitalized on John's mistakes to take over the lead. Craid Lair, who was patiently waiting in third, made his move to get out in front when out of nowhere Mark Beier materialized and moved into second place. With 45 seconds left, Beier stole the lead and claimed the win. Next came the popular class of Open Monster Truck flying in the B main. Phred Gebauer of Team Losi overtook David Wilson to take the win; Wilson second, Racing Bob Kaufman third. In the A Main, TQ J.B. Hunt took the lead and had victory "in the bag" all the way as he lead wire to wire, with Chris Rahe one second behind in second place and Robert Melton in third. The 4WD Open A Main followed, and it was a fight to the finish. At the start, TQ Christians got out of control, and Craig Lair took over-but not for long. Back traffic was treacherous as Lair broke. Chad Christians came back to reclaim the lead but couldn't hold it and swapped with Joe Horvath. It's always those last few seconds that count, however; and James Ward, patiently holding in third, took full advantage of them as he rocketed ahead to win this explosive race. Second place went to Joe Horvath, third to Dave Highfill. Next in the 2WD Stock, John

(Continued on Page 25)

PIT BOARD

TRINITY ANNOUNCES A BATTERY REMATCHING SERVICE

Trinity is now offering a Battery Rematching Service that is accessible through the DEALER only. We will take the used cells sent in by you and run them through our machines which will test the cells and they will be relabeled with their current output specifications. The cells will be shipped back in plastic bags to be rematched and assembled.

By rematching your cells, you will be able to reassemble your cells into packs and instead of having 8 to 10 old, not so good packs, you should be able to assemble 2 to 3 decent packs just by getting the cells with the same capacity in the same pack. This is the method used by all the top racers.

Send 48 or more used cells, (48 cell minimum via UPS) that are loose and free of shunts and braid. We will do the rest! We turn-over your cells in 3 days and return via UPS Ground unless specified otherwise!

PEAK'S NEW PP-45 "ANIMAL" 16T QUAD

Peak Performance unleashes their latest creation, the "Animal". A smooth power band makes this the motor to beat in 2WD buggies and monster trucks. At the 1990 Reedy Race of Champions, Derek Furutani's "Animal" powered RC10 captured the 2WD Modified class while Richard Jamison's "Animal" powered truck took top honors in the Monster Truck class. It is also an excellent 1/10 on-road motor or 1/12 4 cell motor. Based on the world famous Yokomo can, the "Animal" features wet-magnets, heat-sink endbell, high-performance

brushes, and the high-quality workmanship and durability that have made Peak Performance modified racing motors famous on the international racing circuit. Suggested Retail Price \$80.00.

NEW "BLUE" FORMULA TIRES

The "Blue" Formula is a new "Natural Rubber" compound designed for more traction and longer wear. The T683 and T685 are larger diameter for even more traction and stability on slippery bumpy tracks. T690-Rear 5X24 Mini Spike Blue, Same as T659. T681-Front 11X12 Mini Spike Blue, Same as T661. T683-Rear 15X15 Mini Spike Blue, Large Diameter. T685-Front 11X15 Mini Spike Blue, Large Diameter. T679-Rear 5X24 Mini Spike Blue, Same as T667. Schumacher USA. Now available through Trinity Products.

FIRST COAST INTERNATIONAL SPEEDWAY

Arlington could become the site of a national miniature race car championship later this year.

Don Looney, vice president of Radio Operated Auto Racing and the man who decides where the meet is held every year, has been pushing officials with the local miniature car club to get its facilities ready to host a national event.

All that has been missing is two more tracks. That problem is on the way to being solved with the start of construction of two on-road tracks for the radio operated scale model cars at the track in Arlingwood Park.

"Jacksonville would be a good place to hold the national championship because it's basically warm all year round . . . North

Carolina to Florida is one of the two largest regions in the country for radio operated race car enthusiasts," said Looney in a telephone interview from Roanoke, VA.

"Floridians are right in the middle of stock car country; they want to see races with high speeds and curves, and that's what you get with on-road racing as opposed to off-road . . . On-road racing participation has grown 300 percent to 400 percent in the last year," said Looney, formerly a Florida resident.

Economic impact to the city could be \$400,000 city officials estimate. Racing officials said they think it could be as high as 1.2 million. Last year's championships at Birmingham, MI drew 600 entrants from around the country; 709 showed up at Richmond, VA, in 1988. The championship is held every year in September.

Looney said he favors Jacksonville because he has a high regard for the First Coast Auto Racers of Jacksonville, the group that maintains the only public track of its kind in Duval County.

"These new tracks represent three years of hoping and dreaming," said Bob Thompson, president of the First Coast Auto Racers, Inc. "It's so thrilling to see the groundbreaking, and something beginning on the project."

The additions to the race track are being constructed for free by the 202nd Red Horse Civil Engineering Squadron, an Air National Guard unit at Camp Blanding. The group does community service projects in time of peace, said Tom Annis, a senior master sergeant with the squadron.

The additions to the track will be two cement tracks that will allow three types of on-road racing; a 504 foot tri-oval track for racing cars at 70 mph.

Inside the perimeter of the 504 foot track is a 300 foot track for racing 1/10 and 1/12 scale street cars that has a sharp right and left turn to test the racer's reflexes.

The third part of the newly added cement tracks will be a 132 foot long drag strip. Drag racing cars are built for speed rather than turning ability.

Even though the labor was free, the First Coast Auto Racers raised the \$8,000 to 10,000 needed to pay for the materials - mainly the 200 cubic yards of cement.

The 4-year old group has 200 members and offers racing competitions for trophies every Satur-

day afternoon at 3:30 for men, women, and children of all ages and skill levels. They also offer instructional classes on Saturday morning to help people learn about cars they recently purchased.

The current set up at Arlingwood Park includes two clay tracks; a 296 foot long flat, oval shaped track. This is for sprinting off-road cars, which can reach speeds of 25 mph. The second is a 220 foot "true" off-road race track that has hills, curves, jumps and valleys to test the driver's skills at manipulating his car through treacherous terrain.



CUTMAN & LIGHT STORM SPRING NATIONALS

The 2nd Annual Spring Nationals at the "Indoor Track" in

Dallas, Texas took place on March 17th and 18th was a tremendous event where records were made with some of the finest driving ever seen.

Rob "Big Boy" Cutman was the top qualifier in the 2WD Modified race. His fine driving abilities were proven when Rob turning the fastest laps ever seen by a 2WD car on the track. His speed was equal to a 4WD Modified. Rob was using the Speedworks Triad 0670, 13 turn motor. Great show Rob!

Bob "Bullet" Light was the top qualifier in the 4WD Modified race. Bob left the competition behind by 2 laps using Trinity's 1712 TorqZilla, 13 turn motor. Rob took 2nd in this race following Bob.

Congratulations to both Rob and Bob for their outstanding

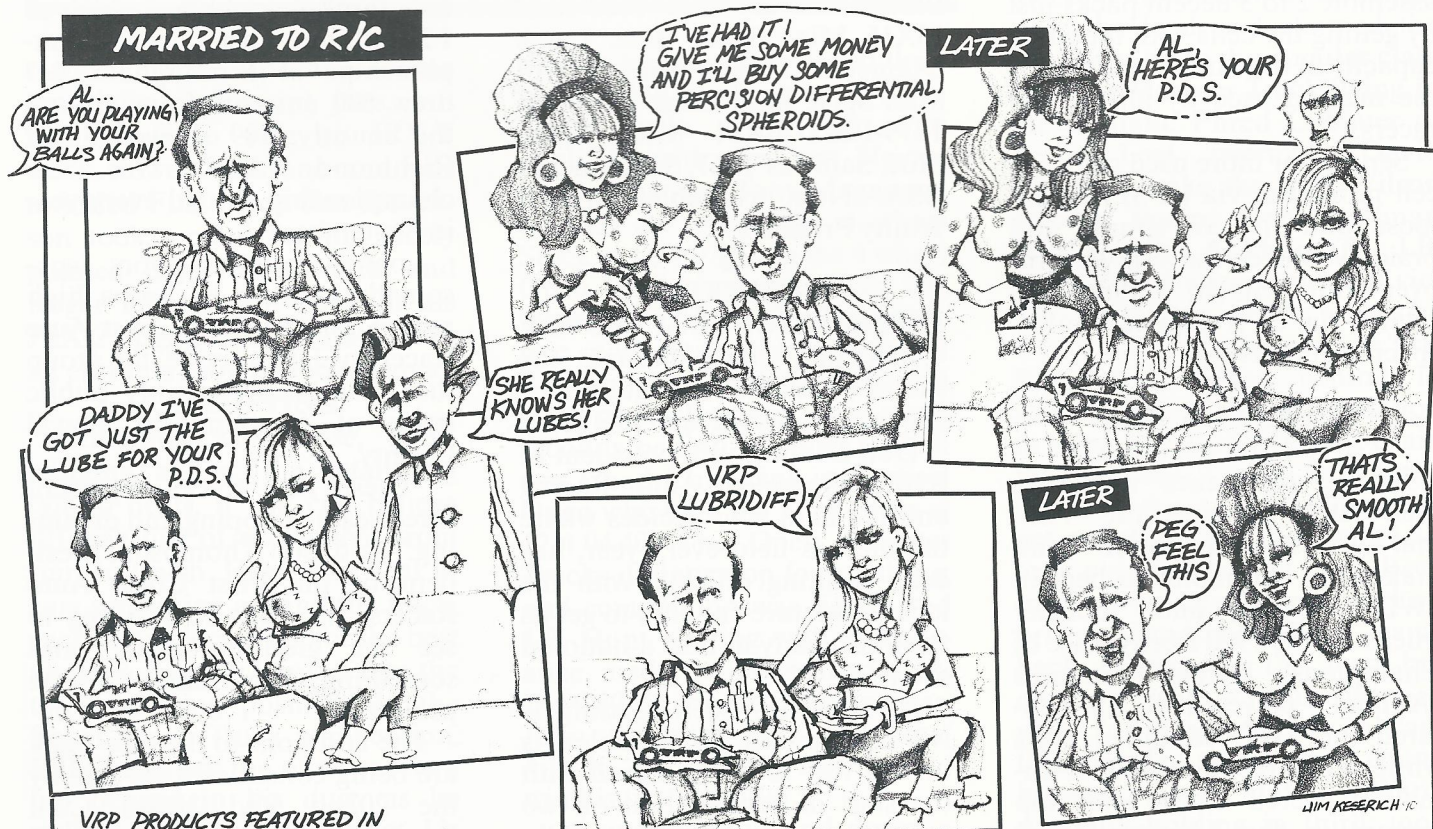

VRP PRODUCTS FEATURED IN
THIS EPISODE OF MARRIED TO R/C

- PRECISION DIFFERENTIAL SPHEROIDS PDS (DIFF BALLS) DB425
- VRP LUBRIDIFF (DIFFERENTIAL GREASE) LD 928

SEND LARGE SELF ADDRESSSED STAMPED ENVELOPE FOR BROCHURE +
TECH TIPS. ADD \$2- DECALS, \$12 FOR T-SHIRT (SIZE)

doing it right
VRP
verona racing products

4555 GROVES RD. #15
COLUMBUS OHIO 43232
1-800-783-4VRP.

parma

Cyclone II MOTOR SERIES

THE NEXT GENERATION

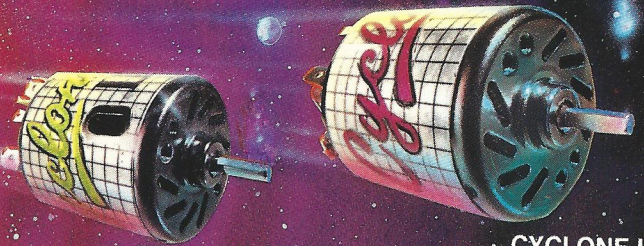

CYCLONE II SUPER STOCK

CYCLONE II ULTRA STOCK

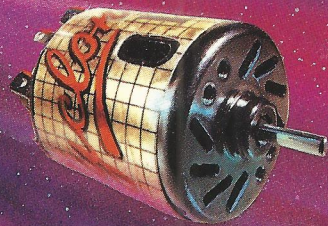

CYCLONE II PRO MODIFIED

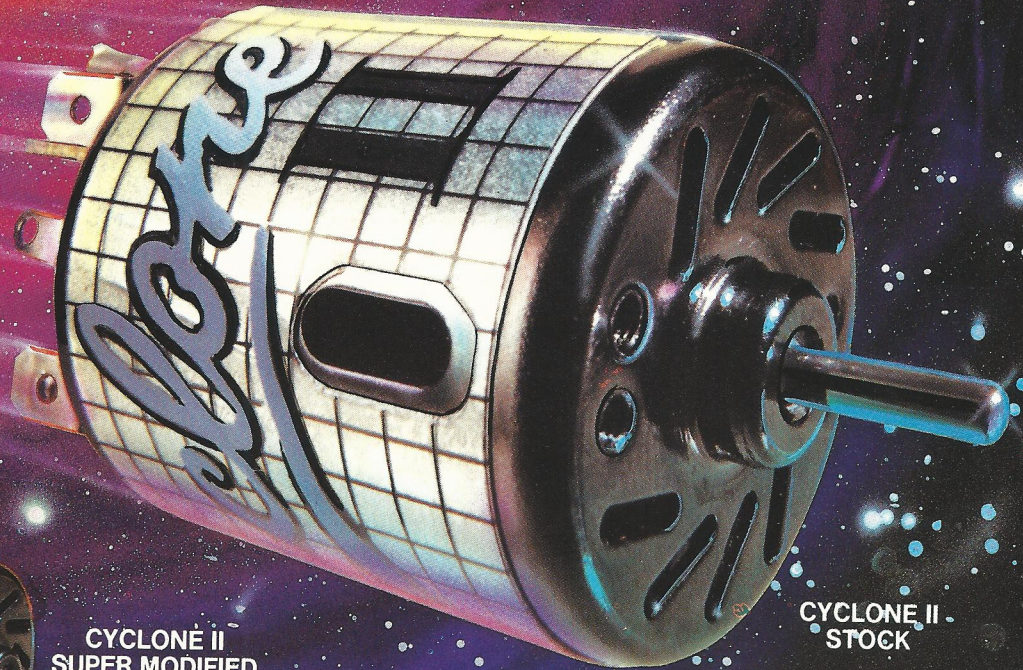

CYCLONE II STOCK



CYCLONE II SUPER MODIFIED

CYCLONE II "T.Q." SERIES

A MOTOR WHO'S TIME HAS COME...

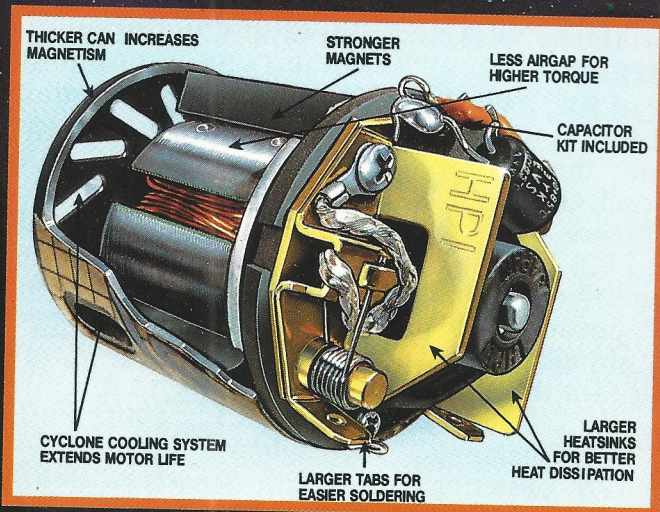

The future of R/C motor technology is at Parma International, Inc. now! The Parma Cyclone II motor series (H.P.I. High Performance Improvement) offers you the most technically advanced motors available at a cost you can afford. These high-tech motors are available in an assortment of machine and handwound versions with your choice of bushings or ball bearings. The new 1.2 mm thick can, combined with new magnet technology provides the strongest magnetic field available today. The Cyclone cooling system and thick endbell heatsinks help prevent the build-up of horsepower robbing heat. Of special note is that the ROAR Stock, Super Stock and Ultra Stock, with all these improvements are still competitively priced.

So don't get left behind at the starting line; race into your local hobby shop and check out the new Parma Cyclone II Motor Series! It's out of this world.



parma
INTERNATIONAL INC.

13927 Progress Parkway • North Royalton, Ohio 44133

LOOK FOR PARMA AT THE RCHTA SHOW!

Parma regrets we cannot supply individual orders on a retail basis. For parts and information, contact your local Parma dealer. SEND \$2.00 FOR A FULL COLOR CATALOG.



CELL REMATCHING

\$1.00 A CELL

VOLT & TIME USING

LAVCO 10 or 20 AMP

COMPUTER EQUIPMENT



Cleaning Available at 50¢ a Cell

Plus Shipping

FIVE FORKS VILLAGE - KING, NC 27021
919-983-3969 1-800-448-4712

victories. Great Job!

RED MONSTER TRUCK TIRES SWEEP CACTUS CLASSIC

At the Fourth Annual Pro-Line Cactus Classic held March 17th and 18th at SRS in Tempe, Arizona, Bill Hancotte placed 1st in the A Main Open Monster Truck Class. J. B. Hunt was TQ and placed third in the Open Monster Truck Class. They were using Pro-Line's monster truck conversion kit for the JRx2 with Toyota extra cab racing body. They also used Pro-Line's Race Engineered Design (RED) Truck Tires: #7050 - Front - Multi rib w/staggered cross bars, #7045 - Rear - Mini-Pin with centered cross bars, Wheels - #2542 and #2543 - Deep dish dyable for JRx2.

OVAL SUPER STAR JOINS TEAM TRINITY

Flyin' Brian Landgraff has officially become a member of the Trinity Factory Racing Team. Brian is world famous for his skills on dirt oval tracks. Brian is also responsible for the Custom Works line of 2 and 4WD dirt oval race cars. Brian is also known as the best tuner of dirt oval cars in the business. Brian will use Trinity motors and

Trinity Pushed batteries to power his race cars.

Brian's "Dominator" 4WD design has been the state of the art when it comes to dirt oval racing. The "Dominator" is so good and so far ahead of its time that 2 direct copies have been put on the market by other manufacturers.

Brian has been doing all the development work for the "Intimidator" the new 2WD dirt oval racer from Custom Works. The "Intimidator" is sure to be as dominate as the "Dominator" has been.

Brian joins Rob Cuttman as the newest member of the Trinity Dirt Oval Super Team!

PEAK TAKES REEDY INTERNATIONAL FRENCH GRAND PRIX

Rick Hohwart of Peak Performance dominated the Invitational class at the Reedy International French Grand Prix held in Lyon, France over the weekend of April 19-22.

After a blazing TQ run in his Peak Performance powered RC10, Rick went on to win all three of the final races to earn the 2WD trophy.

He followed his outstanding 2WD effort with a blistering

4WD TQ run in his Peak Performance powered Kyosho Laser. He captured the top honors in 4WD by winning two of the three finals.

Rick used a Peak Performance Wild Thing in 2WD and a Beast in 4WD to sweep the Invitational racing program.

European team Peak Performance drivers also dominated the regular competition with a TQ and a win in 2WD using a Wild Thing and a win in 4WD with a Rick's Pick.

READY TO ROAR! FORTY DRIVERS COMPETED IN GREAT PLANES' I.R.O.C RACE

Forty of the world's top R/C drivers headed to the first Philadelphia Model Hobby Show held May 5 and 6. They competed five per heat, in the "International Race of Champions" competition sponsored by Great Planes Model Distributors. Among them was Derek Furutani, recent I.R.O.C. champion at the Los Angeles Model Hobby Show.

Heats began on Saturday, May 5 running between 11:30 a.m. and 4:00 p.m., and continued on Sunday, May 6, from 11:30 a.m. to 1:30 p.m. FINALS took place at 2:30 p.m. on Sunday. Action Raceway and Hobby Center, a Gibbstown, New Jersey hobby shop well experienced in organized RC racing, ran the race.

Located at the 30 foot by 50 foot Flat Track, the Great Planes' I.R.O.C. drivers raced the Kyosho Sideways Car, equipped with Novak T4 Speed Controls and a Futaba Magnum Jr. radio. They competed to be the first recipient of the traveling I.R.O.C. Championship trophy, donated by Great Planes/Kyosho. I.R.O.C. Entries:

Trinity Products, Inc. - Joel "Magic" Johnson
WCM Corp. - Steve Guthrie and Steve Cheek
Dan's R/C Stuff - Daniel Moynihan

(Continued on Page 87)

REVOLUTIONARY BREAKTHROUGH DON'T GET LEFT BEHIND

AVERAGE TEST RESULTS:
12% MORE RPMS
 •
20% MORE TORQUE
 •
11% LESS AMP DRAW

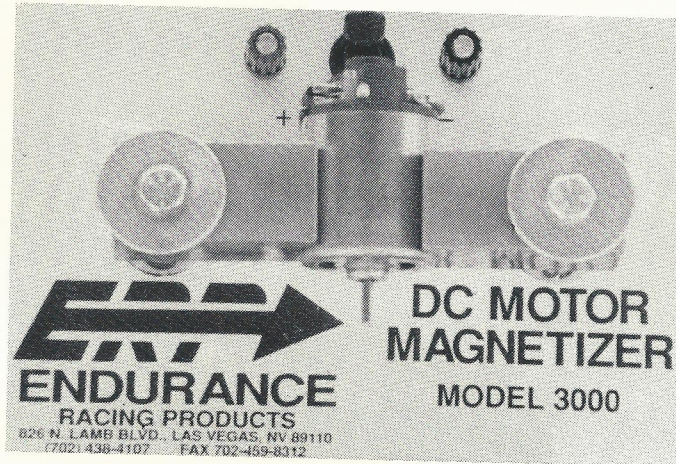

ONLY
\$249⁹⁵

PLUS \$10⁰⁰ Shipping & Handling
 9 LBS SHIPPING WEIGHT

FEATURES:

- EASY TO OPERATE
- SAFE TO USE
- ALL ALUMINUM CABINET (9"x5"x5")
- WORKS ON NEW OR USED MOTORS, STOCK OR MODIFIED

This incredible machine "RE-ZAPS" your motor to increase its overall power output significantly. This safe to operate device ends the need to buy another motor simply because the magnets have lost their power. Easy to use just hookup your 12 volt battery charger (10 AMP), insert your new or used motor, flip the switch and in approximately 20 minutes your motor will scream with new power! Horsepower output is measured by TORQUE x RPMS. This device significantly increases both torque and RPMS while usually reducing amp draw resulting in a more efficient, cooler running motor.

HERE ARE SOME OF THE COMMENTS WE'VE RECEIVED:

- "The D.C. Motor Magnetizer is a MUST TO HAVE ITEM for the racer who wants winning motor power."*
- "You took a throw away motor and made it the best motor I have."*
- "You took a stock motor and made it faster than any of my modifieds."*
- "Best accessory for racers I've seen yet."*
- "Unreal low-end power and the speed is killer."*
- "Last year I spent \$1100⁰⁰ on motors and now I don't have to buy a new one again if I don't want to, but better than that, I've never had this fast of a motor before! This is a whole new world for the RC Racer."*
- "I'm a believer."*

PATENT PENDING - DEALER & DISTRIBUTOR INQUIRIES INVITED



"We make 'ya last longer!"
 826 N. Lamb, Las Vegas, NV 89110
 702-438-4107 FAX 702-459-8312

**DON'T GET LEFT BEHIND ORDER NOW.
 MAIL TODAY OR CALL (702) 438-4107**

SHIP TO:
 NAME _____
 ADDRESS _____ # _____
 CITY _____ STATE _____ ZIP _____
 PAYMENT U.S. FUNDS ONLY.
 AMEX MC VISA CHECK/MONEY ORDER
 CREDIT CARD# _____

SIGNATURE _____ EXP. DATE _____
 X _____

NEVADA RESIDENTS ADD 6% SALES TAX.
 SORRY NO C.O.D.'s. ALL ORDERS SHIPPED U.P.S.

TRU-Magic!™

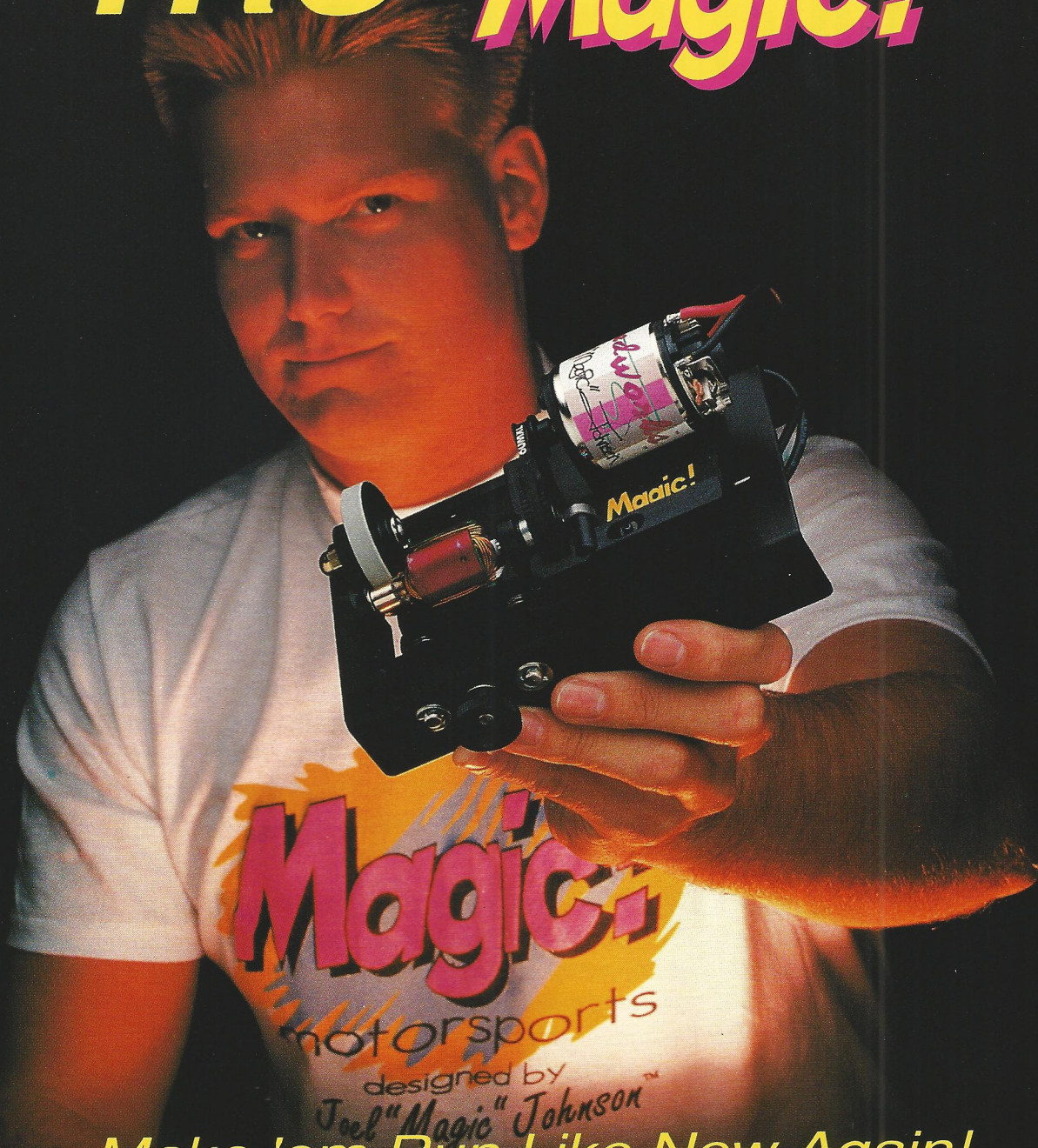

Make 'em Run Like New Again!

Joel "Magic" Johnson's® commutator machine makes your worn-out modified motors run like new!

Motors slowdown because the commutator (the soft copper surface on the armature where the brushes touch) becomes distorted and worn. The brushes wear grooves, leave carbon deposits and burn the edges of the commutator slots. This causes the motor to lose RPM's and power.

Joel's Magic! Commutator Machine corrects these problems by grinding the commutator perfectly round again, leaving a new surface for the brushes to ride on, so they can pass maximum voltage to the armature. Grinding instead of cutting the commutator results in a truer finish and removes less material so the armature lasts longer. There are also no expensive diamond tool bits to sharpen or replace. It is completely portable, fits in any tool box and runs off any 6 cell battery pack (motor and battery not included).

Magic! motorsports™ products are available at your local hobby shop

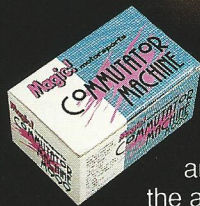

\$149⁹⁹
PN #MM999

Magic! motorsports™ "T" Shirt Only \$12⁰⁰

TRINITY

Trinity Products Inc.
1901 E. Linden Ave., #8 Linden, NJ 07036
(201) 862-1705 FAX (201)-862-6875

Magic!
motorsports
Subsidiary of
Trinity Products Inc.

(Continued from Page 18)

Schultz took the lead off the line and was never seen again, flat-out flying at 13 laps, which was more than the 2 wheel Open Class A Main! Eric Beier came in second, Steve Gilmore took third. Blasting off in the Super Stock Truck A Main, J.B. Hunt powered into the lead. It appeared that Hunt had clear sailing ahead, but Robert Melton stayed close behind. With twelve seconds to go and Hunt looking like the winner, unsportsman-like driving was exhibited by an irate backmarker who drove Hunt into the wall. Melton then easily caught up and won the race. Hunt, managing to untangle himself, came in second and Bill Ogden in third. The Novice A main action was another battle. Steve Taffert, the TQ, again showed superior driving skills as he clinched first place. Only seconds behind him and in the same lap were Shale Witting Ham finishing second and Mike Ryer in third. The next main was the 4WD Open Truck. Driving and unstoppable vehicle, Robert Wedner brought home in the win with Paul Montgomery finishing in second and Tom Cox third. J.B. Hunt, the TQ class, broke while battling for the lead in that race. In the 4WD Stock class, George Johnson took a lap lead victory over second place Tony Maganuco, and a third place Tom Cox.

In conclusion, Tekin's Mickey Thompson Off-Road Grand Prix was a huge success. Not only did many drivers have a great time racing in this event, but they could then watch the real live action and high-flying excitement inside Anaheim Stadium. The RC competition was incredible and driving by all entrants was top notch. Our thanks to Tekin Electronics who made it all possible. Enjoy-and keep the dirt a-flyin'!

**2 Wheel Open
A Main**

- 1st - Mark Beier
- 2nd - Craig Lair
- 3rd - John Schultz

Sanyo 1700 SCE Cells

- up to 639 **\$3.50** each (6 min)
- 640 - 659 **\$4.75** each (6 min)
- 660 - 674 **\$6.00** each (6 min.)
- 675 - 689 **\$7.85** each (6 min.)
- SCE 6 cell stick packs **\$24.95** each

Sanyo 1200 SCR Cells

- Individual Cells*
- Matched 6 cells 480+ packs **\$25** each
 - Matched 6 cells 490+ packs **\$32** each
 - Matched 6 cells 500+ packs **\$42** each

All Batteries LAVco Checked

Minitech Tires & Wheels

- (NEW) East Coast stock motors **\$22** each
- Light Speed stock motors **\$22** each

B&T Racing Team We Accept Mastercard & Visa!
508 Lake Winds Trail ■ Rougemont, N.C. 27572

CALL 919-471-2060 12:00pm to 8:00pm E.S.T.

- 4th - Joe Morettini
- 5th - Steve Ozuna
- 6th - Steve Gilmore
- 7th - Sean Kersten
- 8th - Eric Beier
- 9th - Mike Dunlap
- 10th - Gene Mason

B Main

- 1st - Curtis Stock
- 2nd - Shane Good
- 3rd - Andy Bartucca
- 4th - Dave Krider
- 5th - Marcus Osborne
- 6th - Marty Thompson
- 7th - David Gestoso
- 8th - Will Balisky
- 9th - Roger Tibbets
- 10th - Jessie Watson

C Main

- 1st - Billy Spence
- 2nd - Chuck Beck
- 3rd - David Goss
- 4th - Mike Veiez
- 5th - Ron Vanert
- 6th - Jamie Meyers
- 7th - Ted Bacon Sr.
- 8th - Ted Bacon Jr.
- 9th - Ken Shintani
- 10th - Darin Ishitani

D Main

- 1st - Chris Reynosa
- 2nd - Demonic LeConte

**Open Monster Truck
A Main**

- 1st - J.B. Hunt
- 2nd - Chris Rahe
- 3rd - Robert Melton
- 4th - Brandy Dreifus
- 5th - Steve Ozuna
- 6th - Tom Owens
- 7th - Jeremy Kortz
- 8th - Wylder Barrows III
- 9th - Frank Warnke
- 10th - Dave Krider

B Main

- 1st - Phred Gebauer

- 2nd - David Wilson
- 3rd - Racin Bob Kaufman
- 4th - Phil Ramsey
- 5th - Ted Bacon Sr.
- 6th - Jimmy Gouge
- 7th - Mike Kendall
- 8th - Dan Vels
- 9th - David Gestoso
- 10th - Derek Lamb

C Main

- 1st - Roger Williams
- 2nd - John Hammer Smith
- 3rd - Mike Harkey
- 4th - Rob Nevins
- 5th - Tom Pendergast
- 6th - Mike Fox
- 7th - Ted Bacon Jr.
- 8th - Anthony Munoz
- 9th - Robert Malone
- 10th - David Bush

D Main

- 1st - David Potter
- 2nd - Brian Peterson
- 3rd - Dave Smith
- 4th - Thomas Mendoza
- 5th - Steve Moore
- 6th - Donnie Sieberhing
- 7th - Chris Kelly
- 8th - Jim Warlick
- 9th - Daniel Buerrier
- 10th - John Burrie

E Main

- 1st - Bryan Reichling
- 2nd - Joe Horvath
- 3rd - Bill Gerring
- 4th - Ed Askew
- 5th - Darin Santiago
- 6th - J.G. Sr.
- 7th - Tom Roland
- 8th - R. Adams
- 9th - Duane Warnke
- 10th - Sean Sanchez

F Main

- 1st - Dave Knox
- 2nd - Bob Hale
- 3rd - Wally Jimenez

(Continued on Page 63)

Subscribe Today!



At A



35% Savings Off Cover Price

TRIVIA
STRAIGHT LINE FEVER
TECHNICAL ARTICLES
PRODUCT REVIEWS
ON THE SPOT
PIT BOARD
PIT TALK

NEWSLINE
ASK THE EXPERTS
NEW PRODUCTS
HARD CHARGING
RACING SCHEDULE
WORLDWIDE RACE COVERAGE
IN DEPTH INTERVIEWS

CUT ALONG THIS LINE AND MAIL TO:

COMPETITION PLUS

16582 Gothard Street, Unit Q - Huntington Beach, CA 92647 - (714) 842-3881 - (714) 846-0403 - FAX (714) 848-2969

\$22.95 1 Year - \$42.95 2 Years - \$60.95 3 Years

Name _____

Address _____

City, State, Zip Code _____

Check Mastercard Visa Amount \$ _____

Credit Card # _____ Exp. Date _____

Signature _____

Add \$10.00 for First Class or Canada - Overseas Air Mail \$55.00 - Overseas Surface \$35.00

Come To The . . . OASIS HOBBY PARK



This is the building that houses the hobby shop on the first floor and the lounge on the upper level. On this upper level there are video games and a TV along with meeting rooms.

OASIS: a fertile place in the desert. Recently I had the opportunity to visit the Oasis Hobby Park, in Spring, Texas. Every track I've been to across the country has something to boast about and the Oasis is no exception. It truly is a fertile place in the desert of R/C race tracks. The unique quality that makes Oasis so special is the fact that it is a complete family facility. After taking the grand tour of the facility, given to me by the owner, Israel Ben-Ezra, there was no doubt in my mind that we were all in for a great weekend of rac-

ing and fun. Let's start at the beginning to see how it all began.

It started as a picture in Israel's mind. He had always dreamed of creating a facility where each member of the family could be entertained even if they weren't racing. He felt the key to a successful track was a healthy turnout. By keeping everyone together, not separating the racers in the family from its non-racing members, families would be able to spend more time at the race track. On that premise he began to build: no blueprints, no architects, just that picture in his mind

and the determination to make it a reality. Of course, 29 years in the construction business did help. After months of endless laboring, in less than cooperative weather, the facility was close to being completed. The three tracks were built, each with its own driver's stand; the R/C boat pond and driver's stand was complete, and the hobby shop was being stocked. The staples were in, but the facility was not yet complete. They soon began adding all the amenities that would give the Oasis its special touch, the swings overlooking the



10th SCALE

10th SCALE

2 WD Modified & 4 WD Modified - July 19th - 22nd
 2 WD Stock & 4 WD Stock - July 26th - 29th

Limited to 350 Entries Per Weekend ** ROAR Rules Apply ** ROAR Membership Available At Raceway

CLASSES: 2 WD Modified 4 WD Modified 2 WD Stock 4 WD Stock
 Limited To 2 Classes Per Entry

Stock Classes Will Use "hand-out" Motors

Hobby Haven Will Confirm Your Registration By Mail As Soon As Possible After Receipt Of Application
 Entries Limited To The First 350 Applications Received For Each Weekend

Mail This Entry Form Or A Copy, Along With Your Check Or Money Order Payable To:

HOBBY HAVEN RACEWAY
 72 South N Street
 Livermore, CA 94550

FOR ADDITIONAL INFORMATION CALL:
 Tom Welding Jr. - 415/443-5828

ENTRY FORM

NAME _____ ROAR Membership Number _____
 ADDRESS _____
 CITY _____ CAR _____ MOTOR _____
 STATE _____ ZIP CODE _____ RADIO _____ SPONSOR _____
 TELEPHONE NUMBER _____ SKILL LEVEL Novice Intermediate Expert

CIRCLE CLASS(ES) 2 WD Stock CHOICE OF FREQUENCIES 1st ____ 2nd ____ 3rd ____
 2 WD Modified 1st ____ 2nd ____ 3rd ____
 4 WD Stock 1st ____ 2nd ____ 3rd ____
 4 WD Modified 1st ____ 2nd ____ 3rd ____

ENTRY FEE:

\$45.00 Each Stock Class - \$35.00 Each Modified Class (No Refunds) TOTAL ENCLOSED \$ _____

T-Shirt Given To Each Driver -Your Size Preference (Please Circle One) S M L XL XXL

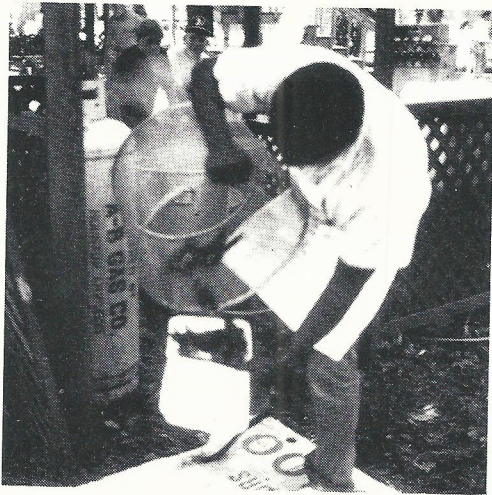

Kris'es Seafood is cooking up the crawfish.

lily pond, the picnic area, the clubhouse with video games and a television, and the concession area. Plus the R/C park lies adjacent to a 15 acre family park including frisbee golf, volleyball, putt-putt, badminton, horseshoes, fire pits, recreational pavilions and campgrounds are soon to be added.

With all the building complete the Oasis was ready for its first major race, The Crawfish Regatta and R/C Fest. This was to be a 1/10 and 1/12 scale on-road and a 1/10 clay oval event. The racing was scheduled to begin Saturday at 9 a.m., however as luck would have it, it was raining. After awhile it stopped and the Oasis crew began to re-groom the tracks. Soon enough we were ready to begin. The first qualifying heats were held on the 1/10th and 1/12th on-road track. This was a tri-oval banked asphalt track with an on-road infield. The the racing was moved over to the 1/10th scale clay oval track. The beautiful thing about this track it that it didn't get really muddy. Even with all the rain we just had we were able to race on the surface after a minimal amount of grooming.

After qualifying was over Saturday night, Kris'es Seafood from Houston set up for the crawfish boil. For three dollars you received one pound of crawfish made up fresh trackside.

HOBBY HAVEN RACEWAY

1990 ROAR OFF ROAD NATIONALS

HOME OF THE REEDY TOP GUN CHAMPIONSHIP & TWISTER OFF-ROAD CHALLENGE

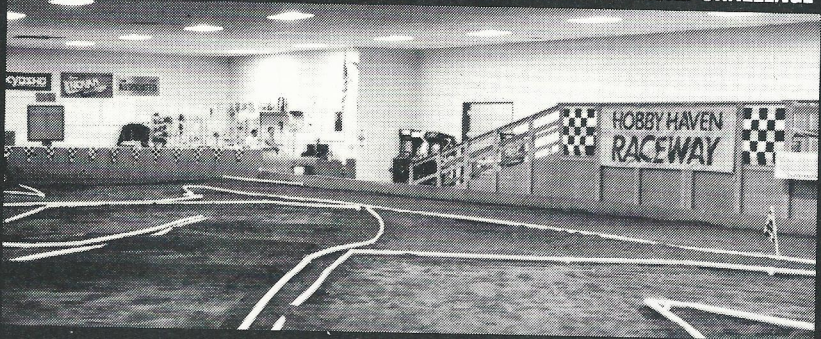

What people are saying about Hobby Haven Raceway:

"It's a high speed track" .. Mike Reedy/Reedy Modifieds

"10" .. Eustace Moore Jr./MIP Products

"One of the best" ... Mike Walker/Twister Motors

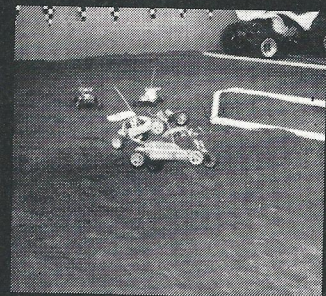
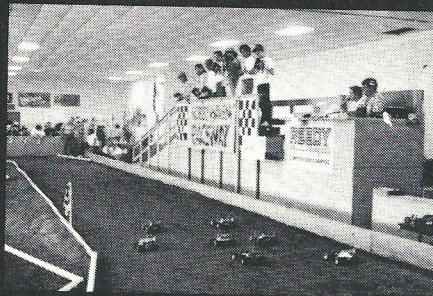

- One of the Largest Indoor Facilities in the Western United States — 16,000 Sq. Feet.
- Ample Paved Parking with R.V. Access.
- Complete Parts Department
- Climate Controlled Racing Environment-A/C & Heating
- Complete Deli/Snack Bar
- Easy Freeway Access From S.F./Oakland Bay Area and Sacramento Area.
- Rental R.C. Cars Available
- Weekly Races and Practice Times — *Call For Information*

Hobby Haven Retail Center
72 South N. Street
Livermore, CA 94550
415/443-5828

Hobby Haven Raceway
3983 First Street
Livermore, CA 94550
415/443-7826

TEKIN

ELECTRONICS, INC.

NOW SHIPPING!

ECONO AND PRO SPEED CONTROLS WITH TORQUE CONTROL

"YOU GET THE BEST"

INTRODUCTION

The TEKIN ESC 310 and 610 are updated versions of the ESC 300 and 600. Several very worthwhile changes have been made. The first is the addition of the torque control adjustment pot. This control limits and regulates the amperage flow to the motor, thereby regulating torque and wheelspin. It prevents wheelspin off the line, and prevents large current surges from sapping the batteries. The TEKIN Torque Control is not 'Just' a torque control. The varitorque design adjust the limiting with position of the trigger. This allows for minor variations in the track traction and motor output, giving you the smoothest response and quickest laps. When the torque control kicks in the motor current is cycled on and off about 10 times a second. This controlled cycling of the throttle helps the rear tires develop more traction, just when you need it most.

A torque control test point (Patent Pending) is provided to allow precise adjustments in the pits. Shunted Mosfets are used for maximum amperage. Other features include a double filtered B.E.C. with 5.5 volts output for an extra 10% faster steering servo, and low operating voltage to eliminated stuttering. The braking action is even stronger, and an interlocking case seals out dust and moisture. The TEKIN Speed Controls use our own exclusive, custom integrated circuit (the world's first) designed specifically as a Speed Control. This keeps size down, and performance up.

"1990 U. S. R.O.A.R NATIONAL CHAMPION"

PREMIUM QUALITY SPEED CONTROLS

CASE SIZE	ESC 310	ESC 610
	1.4" L X 1.5" W X .5"H	
WEIGHT <i>Less Wires</i>	1.3 oz.	
RESPONSE TIME	.018 SECOND	
EFFICIENCY	99.9% CURRENT	
POWER CONSUMPTION	.018 Amp LED On	
PEAK CURRENT RATING	1260 Amps	1410 Amps
VOLTAGE DROP <i>10 Amp Load</i>	.03 V	.025V
TEMPERATURE DRIFT	LESS THAN 1%	
VOLTAGE INPUT	4-10 Cells 2.8 - 14 volts	
Continuous Current	300 Amps 350 Amps	
PLUGS*	FUTG, FUTJ, AIR, KO, KYOSHO	

* Coming June 5
Universal Plugs

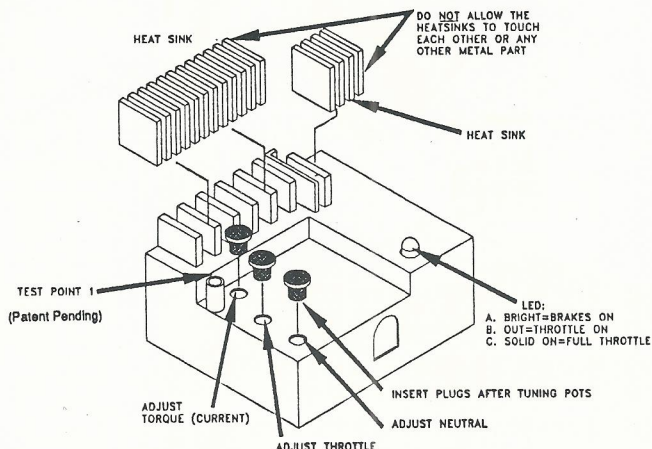

ELECTRONIC SPEED CONTROL ADJUSTMENTS

ESC310 AND ESC610

Electronic Speed Controls with Tempfet overheat protection, Varitorque adjustable electronic torque control, and semi-linear motor drive.

Recommended for all applications with medium to poor traction, where large increases in driving ease and speed can be expected. Especially recommended for 2wd off road.

Designed, developed, race tested, and manufactured in the U.S.A. by the world's first (1982) and oldest Mosfet speed control builders. Take advantage of our experience!

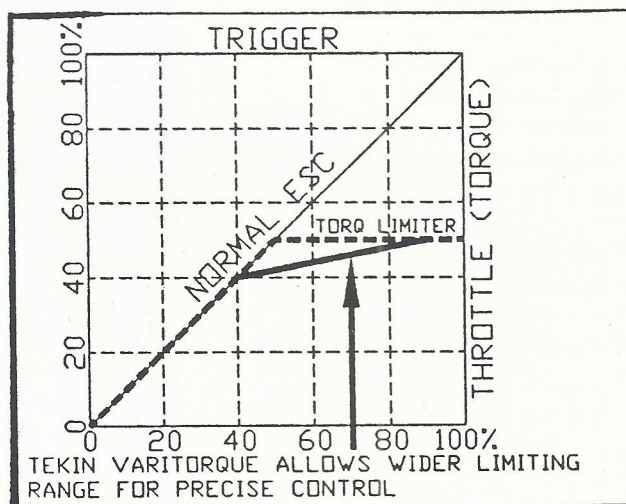

TORQUE CONTROL DOES NOT AFFECT TOP SPEED OF CAR!

"GREAT FOR BEGINNER AND EXPERT ALIKE."

#ESC 310 \$115.99

#ESC 610 \$165.00

970 Negocio • San Clemente, California 92672 U.S.A.

(714) 498-9518

Right Top: A shot of the 1/10 & 1/12 scale track. This is a banked tri-oval with and on-road infield. Right Middle: The 1/10 scale clay oval track. This track will be hosting the regionals this year. Right Below: The Off-Road Track.

This allowed for some good bench racing and gave everyone a chance to plan for Sunday.

Sunday morning started with one more round of qualifying and then the A Main events. Another aspect that is very important to the future of R/C racing is spectators' involvement, and Israel is well aware of this. During the break, while the mains were being set up, Israel arranged a few fun events to get the spectators involved. First he invited a racer from each of the different cities represented to participate in a Triathlon. Each racer was given a rental car for this race. The three legs of this event consisted of: 1.) A sprint to their pits to get the car and then back to the track. 2.) Drink down a large cup of Pepsi, pick up the car out of tech, put it on the track, and sprint up to the driver's stand. 3.) One lap on the on-road track driving the car in reverse.

This event got the spectators involved as they all cheered for their favorites and it was a lot of fun for everyone. The winner was Chris Allison. Two other events that were held was a Media Clay Oval Race and a raffle for the spectators.

The boards were set and we were ready for the main events. The TQs fared well in the main events, as a matter of fact, five out of six of the TQs went on to win their respective A Main events.

In the 1/10 scale On-Road Stock A Main David Joor took the victory after battling it out with Trevor Rosson for almost the entire race. In the Modified A Main Kevin McIntyre from Louisiana was your winner. He ran a great race! In the On-Road Novice class Billy Holt took home the first place honors after he nudged out Ryan Hudson for the lead. The last on-road event



MORE POWER TO YOU



UNLEASH THE POWER THAT ONLY PARMA MATCHED AND SUPER MATCHED SANYO SCR'S CAN OFFER. FOR YEARS PARMA HAS BEEN PRODUCING CONSISTENT, MATCHED BATTERY PACKS FOR RACERS AND HOBBYISTS ALIKE. DON'T GET BLOWN AWAY WITH THE REST. INSIST ON THE BEST; PARMA SANYO SCR'S. THESE CELLS PACK POWER!

SHOWN ARE PARMA SANYO SCR'S AVAILABLE IN A VARIETY OF PACKS AND CONFIGURATIONS.

SANYO



PARMA SANYO SCR HIGH RATE DISCHARGE CHARACTERISTICS

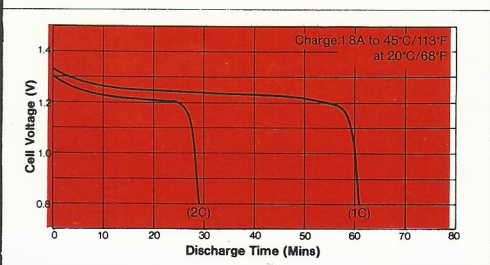

Parma regrets we cannot supply individual orders on a retail basis. For parts and information, contact your local Parma dealer. SEND \$3.00 FOR A FULL COLOR CATALOG.



parma
INTERNATIONAL INC.

13927RCP Progress Parkway, North Royalton, Ohio 44133
LOOK FOR US AT THE RCHTA SHOW!

UFRA® "BLACK DOTS" COME TO INDY!

THE ULTIMATE IN
PROFESSIONAL QUALITY
RACING TIRES

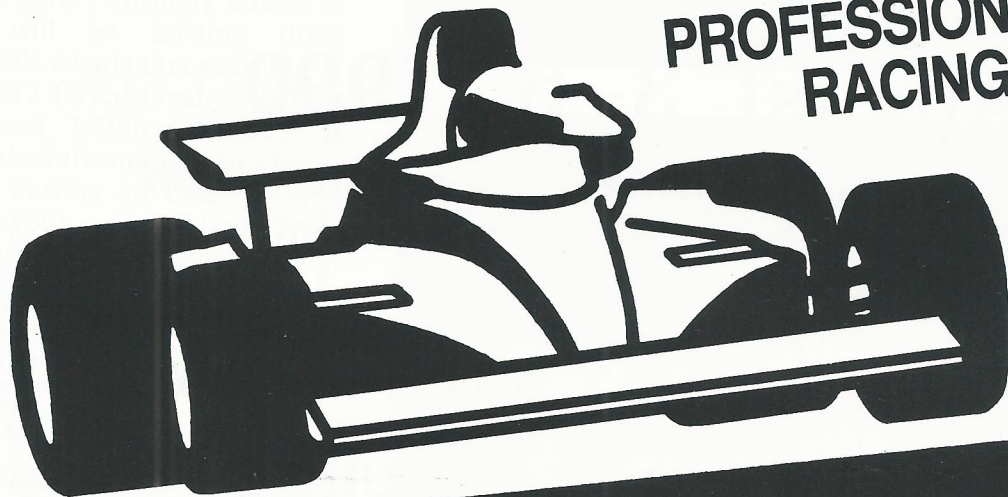

UFRA® is the ultimate professional quality racing tire made of a revolutionary superior natural sponge rubber compound imported exclusively from Switzerland's UFRA® MODELLISMO by Twinn-K of Indianapolis.

- 1/8, 1/10, 1/12 AND SLOT SIZES ARE AVAILABLE AS "BLACK DOTS" AND "BLACK DOT FOOTPRINTS"
- EXCEPTIONAL LONG-LASTING WEAR
- LOWER ROLLING RESISTANCE - HIGHER SPEEDS
- PRECISION TRUED HOLDING POWER - NO TIRE "HOP"
- EDGE RADIUS PRACTICALLY ELIMINATES CHUNKING
- MAXIMUM TRACTION ON CONCRETE, ASPHALT, CARPET, DIRT AND CLAY
- ENDORSED BY NATIONALLY RATED DRIVERS

IF UNAVAILABLE LOCALLY,
CALL TWINN-K FOR PRICE & DELIVERY INFORMATION
SEND \$2.00 TO TWINN-K FOR 1990 PRODUCT CATALOG

TWINN-K INC.

"MAKE THE INDY CONNECTION"

SCALE MODEL RACING TIRES & ACCESSORIES FOR CARS, PLANES & BOATS

TWINN-K, INC. • P.O. BOX 31228 • INDIANAPOLIS, IN 46231 • TELEPHONE: 317-839-6579 • FAX: 317-839-8928

R.O.A.R. REGION I DIRT OVAL - CHAMPIONSHIP -

COOPER'S R/C RACE CENTER
CALLANDS, VA

August 3-5, 1990

Thursday--Open for Practice 9am - 9pm

Friday--Qualifying-11am - Until

Saturday--Qualifying-11am - Until

Sunday--Main Events-11am - Until

FREE T-SHIRT WITH ENTRY

FULL-FENDER DIRT BODY &

SPONGE TIRES REQUIRED

ROAR RULES STRICTLY ENFORCED

Hand Out Stock Motors for Stock Class

Lots of Parking

Air Station

AMB Computer Lap Counter

Well Stocked Hobby Shop

Area to Park Campers--NO Hookups

150 Pits

110v AC for Charging

Snack Bar

Bleachers for Spectators

Stools in Pit Areas

Local Lodging Information & Directions

Available Upon Request

ROAR Memberships Available At Track

Name _____					Phone () _____	
Address _____					ROAR # _____	
City _____		State _____		Zip _____		
Sponsor(s) _____						
	<input type="checkbox"/> 2WSprint	<input type="checkbox"/> 2WS	<input type="checkbox"/> 2WMod	<input type="checkbox"/> 4WS	<input type="checkbox"/> 4WMod	Send to:
	<input type="checkbox"/> \$25.00	<input type="checkbox"/> \$35.00	<input type="checkbox"/> \$25.00	<input type="checkbox"/> \$35.00	<input type="checkbox"/> \$25.00	Cooper's
Radio	1. _____	1. _____	1. _____	1. _____	1. _____	Rt. 4 Box 122-B
Freq.	2. _____	2. _____	2. _____	2. _____	2. _____	Chatham, VA 2453
Choice	3. _____	3. _____	3. _____	3. _____	3. _____	(804) 724-4182
						(804) 724-7342

T-SHIRT SIZE: _____

Payment MUST Accompany Entry Form--Confirmation Upon Receiving Entry

was the 1/12 scale Stock A Main. The event was won by Bob Ingersoll.

Then we moved over to the 1/10 clay oval track. In the 2WD Stock class Allen Nielsen took home the gold. In the Modified class, the man behind Chu Manufacturing, Randy Chu, showed them what he could do, and took first place in this class.

So ended a great weekend of racing and fun. If you have the opportunity to visit the Oasis Hobby Park I strongly advise it. They will be hosting three Regionals events this year, the 1/10 & 1/12 Paved Oval, 1/10 Dirt Oval and 1/10th On-Road. If you'd like information or interested in starting an Oasis Hobby Park in your area, call Israel Ben-Ezra for franchise information at (713) 443-6003.

ON-ROAD NOVICE A MAIN

- 1st - Billy Holt/TQ
- 2nd - Ryan Hudson
- 3rd - Ginna Russell
- 4th - Dan Taylor

1/10 ON-ROAD STOCK A MAIN

- 1st - David Joor/TQ
- 2nd - Trevor Rosson
- 3rd - Barry Raborn
- 4th - Claudio Tamburri
- 5th - John Ber
- 6th - Tim Hudson
- 7th - John Clouatre
- 8th - Keith Beasley
- 9th - Jason Hutchins
- 10th - Jay Pena

B MAIN

- 1st - Brad Russell
- 2nd - Tom Mankin
- 3rd - Tim Martelon

C MAIN

- 1st - Larry Blackshear
- 2nd - Steve Knapp
- 3rd - Jerry Cowart

ON-ROAD 1/12 A MAIN STOCK

- 1st - Bob Ingersoll
- 2nd - Charles Burns
- 3rd - Doug Anderson

ON-ROAD 1/10 MODIFIED A MAIN

- 1st - Kevin McIntyre
- 2nd - Bob Ingersoll
- 3rd - Craig Jesmer
- 4th - Barry Rayborn
- 5th - Charles LeBlanc
- 6th - Glenn Gaspard
- 7th - Trevor Rosson
- 8th - Brett Adams
- 9th - Randy Chu
- 10th - David Joor

B MAIN

- 1st - Jeff Ball
- 2nd - Nick Manteris
- 3rd - Paul Conover

C MAIN

- 1st - Mark Buford
- 2nd - Doug Anderson

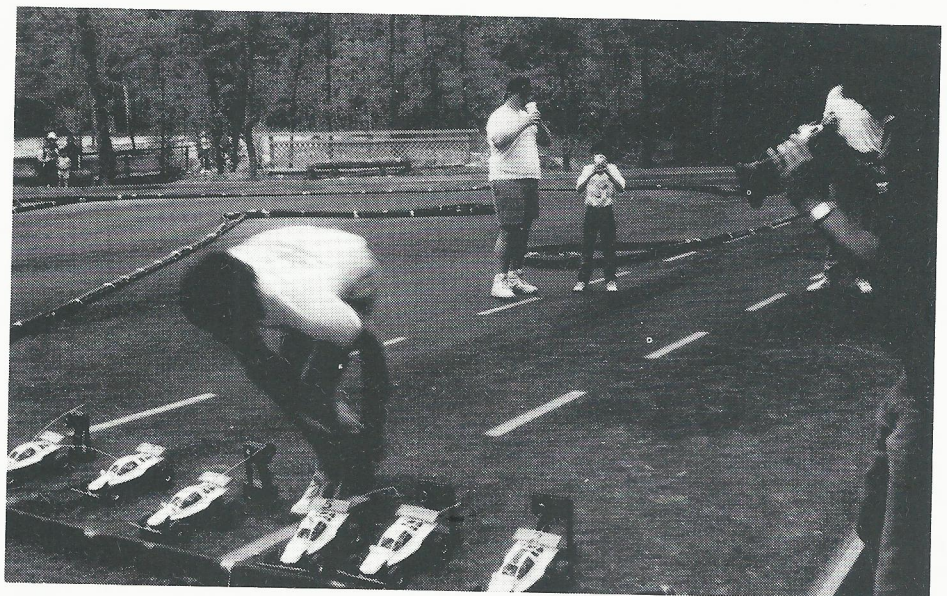
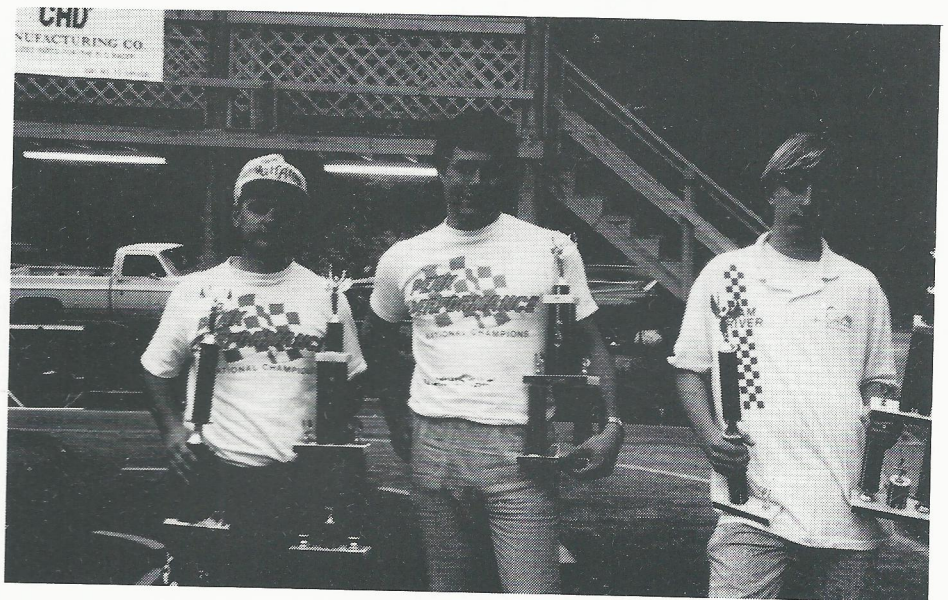

Top: A Main winners in 1/10 scale clay oval. L. to R. Rhett Wilder, Randy Chu, Cliff Alexander and Allen Nielsen. Middle: A Main winners in 1/10 & 1/12 on-road. L. to R. Kevin McIntyre, Bob Ingersoll, and David Joor. Bottom: Bob Ingersoll sprints to get his car for the Triathlon held on Sunday, while Brett Adams and Matt Martin try to drink down their pepsis.

ONLY

HI-IQ

CAN UNLEASH THE DEMON IN YOUR NI-CAD

BY PRECISION CHARGE, DISCHARGE, CYCLING,
GRADING/MATCHING, AND MORE.

• MICRO-COMPUTER STRUCTURE.
EXTREMELY USER FRIENDLY.
NO NEED TO READ MANUAL for most functions

even first time used
• socketed EPROM I.C. for easy do-it-yourself software
version exchange

• EXPANDABLE - two piggyback modules** - to be
announced:

- 1) AC to DC Converter to allow use of AC house current
- 2) MULTI-FUNCTION MODULE to allow hook-up and auto-switching of up to 8 packs, cell equalizing without splitting packs, serial port for printer or host PC interface, tachometer, dynamometer, lap counting and more

• DIGITAL KEY PAD for function selection and data entry. NO OTHER SWITCHES OR CONTROLS

• HEFTY HEAT SINK for VERY HIGH POWER CAPACITY

• POWER INPUT (reversed polarity protected) - car or motorcycle battery or suitable power supply

• DIGITAL VOLTMETER probes. Also for remote volt sensing during test-discharge for increased accuracy

• THERMAL PROBE** can be connected to METER for Thermal Charge*, THERMOMETER* function & COOL-OFF auto cut-off

• MOTOR CURRENT TEST up to 30A cont. / 100A peak for fine tuning of gears (props), bearings and commutators
• new MOTOR / GEAR BREAK-IN cycling

• STOP WATCH function*

• Motor SPEED CONTROL EFFICIENCY TEST* - volt. drop @ 10A load (finally reliable proof your VICTOR S/C is the best)

- True ALPHANUMERIC DISPLAY guides you by MENU WITHOUT READING MANUAL. Very friendly machine.
- Continuous display of Amps, Volts, time, mAh during functions
- Plain language messages (no codes)

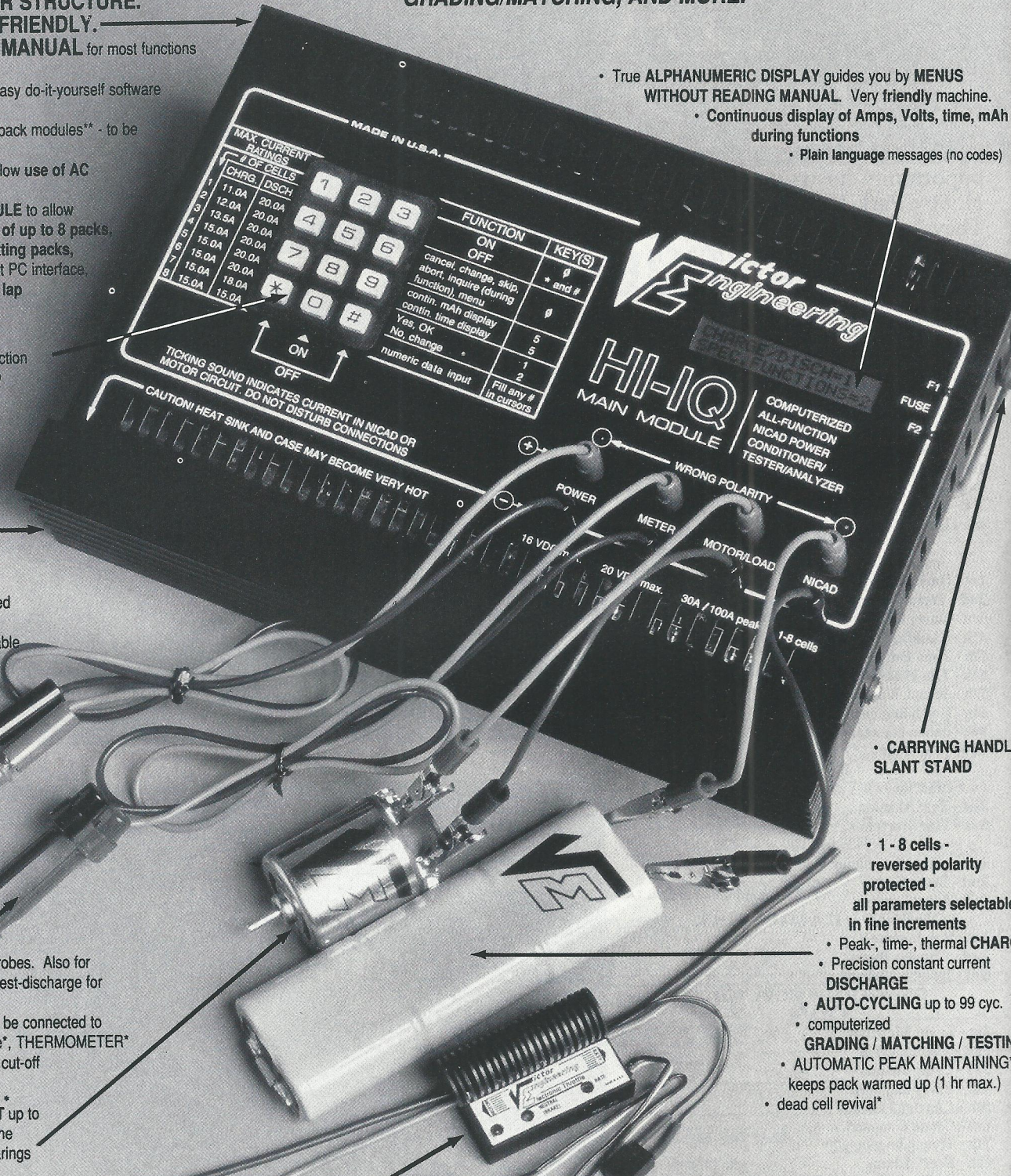

• CARRYING HANDLE SLANT STAND

• 1 - 8 cells - reversed polarity protected - all parameters selectable in fine increments

- Peak-, time-, thermal CHARGE
- Precision constant current DISCHARGE
- AUTO-CYCLING up to 99 cyc.
- computerized GRADING / MATCHING / TESTING
- AUTOMATIC PEAK MAINTAINING* - keeps pack warmed up (1 hr max.)
- dead cell revival*

* OPTIONAL SOFTWARE

** OPTIONAL HARDWARE & SOFTWARE

Victor Engineering
 380 Camino de Estrella, Suite 170
 San Clemente, CA 92672
 Phone (714) 496-9701

Monday - Friday 9 a.m. to 5 p.m. PST
- Phone or write for more information.

3rd - Johnny Ber
CLAY OVAL 2WD STOCK
A MAIN

1st - Allen Nielsen
2nd - Mike Kressley
3rd - Shawn Jankowiak
4th - Colville Garrett
5th - Matt Martin
6th - Chris Allison/TQ
7th - Barry Raborn
8th - Mark Kopechi
9th - Edwin Braziel
10th - Don McMillan

B MAIN

1st - Jane McMillan
2nd - Rhett Wilder
3rd - Ron Hannon

C MAIN

1st - Stan Huey
2nd - Justin Cornett
3rd - Ricky Gollrisch
2WD MODIFIED CLAY OVAL

A MAIN

1st - Randy Chu/TQ
2nd - Chris Allison
3rd - Jane McMillan

4th - Paul Conover
5th - Steve Knapp
6th - Don McMillan
7th - Jim Hobby

SPRINT A MAIN

1st - Rhett Wilder
2nd - Jim Hobby
3rd - Ed Rains

HEAVY METAL
STOCK A MAIN

1st - Cliff Alexander
2nd - John Dietrich

□

By The Way . . .

Look Out Bob Bondurant and Skip Barber . . .

. . . Here comes Jay Pena! Jay Pena, a six year veteran on the R/C racing circuit saw the need to develop a school for newcomers to get acquainted with the sport. He remembers when he first got started and had a hard time getting information out of some of the top drivers in his area. Jay watched several young talented racers get frustrated because they didn't have the right set-up or the knowledge to improve it. He wanted to make it a little easier on the beginners, therefore he developed the Jay Pena Driving School.

The school is held on Saturdays from 10 a.m. til 4 p.m. and the cost is \$20.00 per person. The class is held for 8-10 drivers so each one can received individual attention. The class informs the racers on equipment purchases, car set-up, like caster/camber adjustment, diff setting and rebuilding bearings. They learn not by trial and error but by race proven techniques. Also Jay teaches driving techniques. He helps them find the apex, shows them the fast line and teaches trail-breaking.

Most of the racers who attend Jay's school are teenagers. Jay's classes give these young adults



The Oasis Racing Team, most of whom are graduates of Jay's School.

more confidence and helps them to become winners, which improves aspects of their everyday lives, as well.

Another service Jay Pena's school offers is organizing and making arrangements for the kids to attend major events across the country. Last year Jay arranged, with the parents of several kids, the trip to Michigan for the Off-Road Nationals. He

assures parents that the kids will have adult supervision and that there is never any alcohol or drugs. He is planning the same for this year's Nationals.

The school is presently being held at many different tracks in the Texas area, including Oasis. If you'd like more information on developing a Jay Pena Driving School in your area contact Jay at (713) 933-7245 between 7 and 9 p.m.



Left: Chuck Lonergan was crowned the 1990 4-Cell Stock National Champion after winning the A Stock Main. Chuck was also the second fastest in qualifying.

ROAR 4-CELL

Every time the SEMROCC Club puts on an event, you know it is going to be run with plenty of staff and organization. The SEMROCC Club is one of the most active clubs in ROAR, when it comes to putting on national events. They always have a good showing and represent ROAR well.

This Trinity ROAR 4-Cell Nationals was held at the Radisson Hotel in Detroit. The track was large, by 4-Cell standards. There was a lot of acceleration points on the track and combined with the carpet being laid on top of carpet battery life was crucial. The race was held in the ballroom of the hotel. There was plenty of room for spectators. In fact, they even supplied chairs to sit down and watch the excitement. The room rates were a little higher than SEMROCC would have wanted, but with the quality of the hotel it was worth it.

The schedule for the event was: Practice on Thursday, two rounds of qualifying on Friday and two round on Saturday. Sunday was set aside for the mains. SEMROCC used the now popular tee times for practice. This is where you get to sign up to



Right: Rick Hohwart lead the Modified A Main from turn two until the finish with his Peak Performance and Associated 12L combination. Rick became the first 1990 4-Cell Modified National Champion for the 90s.



NATIONALS



practice at a specific time. I really like this system. You always know exactly when you are going to run practice, so you don't have to wait in line like Disneyland, waiting to run. The system worked to perfection as the club kept it right on schedule. Every ten minutes a practice session went off. On the average you were able to run about every hour and a half.

Qualifying was also different from normal standards as they used the IFMAR qualifying system. With this system each driver starts individually. This eliminates first corner crashes to get the hole shot and a clear track. This also eliminates drivers racing with each other. When a faster car comes upon you, you know now he must be fast and normally they will let you by. The disadvantages to the system are for spectators as it is confusing to figure out who is the fastest and the other disadvantage is it isn't as exciting to watch. The system is also a lot harder for lap counting. Everybody is on a different clock, so if a transponder doesn't work it is extremely difficult to clock the car.

The Novak Dustbuster Invitational was the crowd's favorite. The drivers in this event all took Dustbuster vacuum cleaners, took the motors and batteries out of them and installed them in their R/C car. They also all used Andy's custom painted 300ZX bodies. The drivers ran one qualifier and one main event. In qualifying the drivers were having fun, enjoying the dicing and slicing. It looked more like a demolition derby than an IROC race. For the mains, they took it a little more seriously. Rick Hohwart, who did start from the pole, took home the win. In fact, Rick was going so fast with that 300ZX body, Dustbuster motor and batteries that he would have qualified for the A Main Stock.

Personally there isn't any race more enjoyable than one held in a hotel. With everybody staying at the same location it brings the participants closer together. You can practice 'til the wee hours of the morning and there is no danger of being rained out.

The one major problem at



Joel "Magic" Johnson was the Sanyo Triple Crown winner with his Trinity/Corally combination.

hotel races is charging. Unless you have one of those high tech jump boxes, you have to let your batteries sit for eight minutes without a boost before the race. The problem was solved by Class Chargers. Class Recreational

Products of Utica, NY truly made a class statement by providing ten Class Chargers to put on a table for everyone to use after teching to juice up their batteries. I am sure all the racers were very grateful.

STOCK QUALIFYING

The Trinity handout motors all seemed to be consistently fast. This meant that it wasn't going to be a horsepower battle, just straight out driving skill. Jon Orr told everybody he came to race by taking the first round TQ with a time of 39, 8:04.2. Chuck Sommers had the second fastest time with a 39, 8:06.56. In all there were five 39 lap runs and five 38 lap runs, that made up the A Main in round one.

Round two abolished all of the 38 lap runs in the A Main, you now had to turn at least 39 laps to make the A Main. Jon Orr and his Corally car improved his pole position time with a run of 39, 8:00.71. So close to 40 laps. Aaron Treppa moved into the second

CAPPED TIRES FOR:

- RC-10 Rear: #0090
- Dominator: #0092
- 1/10 scale fronts: #0095 soft, #0999 firm
- 1/10 scale rears: #0096 soft, #1000 firm



Made in the U.S.A.

THE LEADER IN RUBBER CAPPED R/C TIRES!

We've got'em! The hottest new item in R/C racing tire technology — Rubber capped foam tires from CKW! Six of ten drivers at the 1989 Thunderdrome rode CKW's to victory — Find out why they're the winning choice in capped racing tires!

- Pre-suffed and ready to run
- Chunk-resistant foam centers
- Less prone to "blowouts"
- Strong, rigid rims; less flex, less distortion in cornering.



1889 W. Commonwealth, Unit #1 • Fullerton, CA 92633
(714) 738-1312 • FAX (714) 738-1328

ASTRO COBALT RACING MOTORS

proudly made in USA



Top Fuel Drag Motor

- Winding.....Six Turns of #19 Ga. Wire
- Free Speed.....48,000 RPM
- Power Output.....450 Watts
- Nicad Battery8 to 14 Cells
- Ten Powerful Samarium Cobalt Magnets
- Skewed Seven Slot Armature Lamination
- Large Brushes with Adjustable Timing
- Rugged 0.440 in. Diameter Commutator
- Specially Designed to WIN Drag Races
- Model 7510Suggested Retail \$99.95

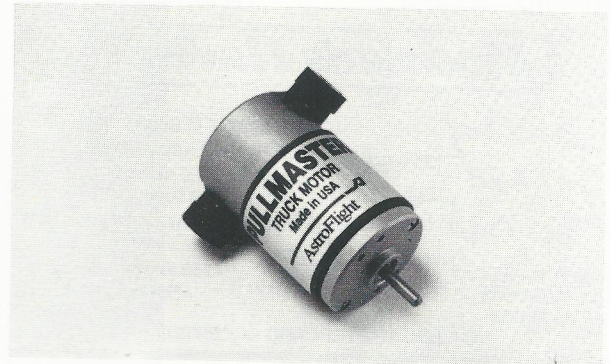

Pullmaster Truck Motor

- Winding.....Twelve Turns #22 Ga. Wire
- Free Speed.....19,000 RPM
- Power Output.....250 Watts
- Nicad Battery.....8 to 14 Cells
- Ten Powerful Samarium Cobalt Magnets
- Skewed Seven Slot Armature Lamination
- Large Brushes with Adjustable Timing
- Motor Rotation Very Easy to Reverse
- Specially Designed for Truck Pulling
- Model 7505.....Suggested Retail \$89.95



DC/DC Constant Amp Charger

- Specially Designed for Big Electric Systems
- Charges One to Twenty Eight Cell Nicads
- Charges 250 mahr to 1700 mahr Nicads
- Charges at Constant 1 to 4.5 Amp Rate
- Charges Astro, Robbe, and Graupner Sys
- Works from 12 Volt Automobile Battery
- Perfect for Giant Scale R/C Airplanes
- Perfect for Unlimited R/C Racing Boats
- Perfect for Dragsters and Monster Trucks
- Model #112 Suggested Retail \$129.95



Sanyo Battery Packs

- 10x600 SCR Sanyo Drag Pack.....#7610
- 12x600 SCR Sanyo Drag Pack.....#7612
- 14x600 SCR Sanyo Drag Pack.....#7614
- 10x900 SCR Sanyo Drag Pack.....#7410
- 12x900 SCR Sanyo Drag Pack.....#7412
- 14x900 SCR Sanyo Drag Pack.....#7414
- Six Turn Drag Armature.....#7501
- Twelve Turn Pulling Armature.....#7501
- Replacement Brushes.....#5044
- Super flex Silicone 14 Ga.Wire.....#4040

HobbyShopper's Guide

1/10 and 1/12 Scale Electric

PARTS AND ACCESSORIES

Modeler's Haven



NEW STAGE III BATTERIES
SCE RATING 630 AND UP
SCR RATING 450-510
CALL FOR PRICES
ALSO COMPUTER MATCHED GONZOS

PROMPT SAME DAY
U.P.S. SHIPPING
(216) 499-8000

4255 Portage St. N. W.
North Canton, OH
44720

VISA AND MASTERCARD ACCEPTED

ROAR OFF-ROAD CHAMPIONS
FLORIDA STATE CHAMPIONS

CENTRAL FLA. HOBBIES, INC.

5600 W. Colonial Dr., Suite 311
Orlando, FL 32808

Glenn Harkey
Sharon Harkey
(407) 295-9256

Discount Prices
UPS Service
Major Credit Cards Accepted

RACEWAY HOBBIES

Complete RC Connection
RC Supplies & Track

(407) 468-4338
Terry • Lou • Bill



"Come Race With Us"

Lexington Shoppes • 6845 So. U.S. 1 • Port St. Lucie, FL 34952

THIS SPACE IS AVAILABLE FOR
YOUR HOBBY SHOP'S
LISTING
CALL FOR INFORMATION
and RATE (714) 846-0403

Action PRO SHOP



The R/C Car Specialist

20% Discount on All Parts
Lowest Prices On:
Car Kits
Electronics, etc.
We Will Ship COD

MOTORS &
BATTERIES
30% Off
Vince Palazzolo, Owner

3224 FOURTH • WYANDOTTE, MI 48192 • (313) 283-8322



(718) 389-4485

THE HOBBY PRO SHOP
Specializing in Radio Control



ALL NAME-BRAND MERCHANDISE
CALL OR STOP IN FOR EVERYDAY LOW PRICES.



476 Humboldt St.
Brooklyn, N.Y. 11211



"WE RACE WHAT WE SELL"

Prescriptions Available - Performance Proven



Quality Lenses Are The Winning Edge
Visa & Mastercard

P. O. Box 25943
Tamarac, FL 33320

Dealers Call
(305) 572-8927



You Break - We Fix
Over 100 Companies Stocked
WE DISCOUNT EVERYTHING
If We Don't Have It - We Can Get It!

R & W Inc.
HOBBIES & CRAFTS

Authorized Ace and Futaba Dealer
Full Service Department - Home of Teddy's R/C Raceway
430 Shoemaker St., Swoyersville, PA 18704,
(717) 283-3066

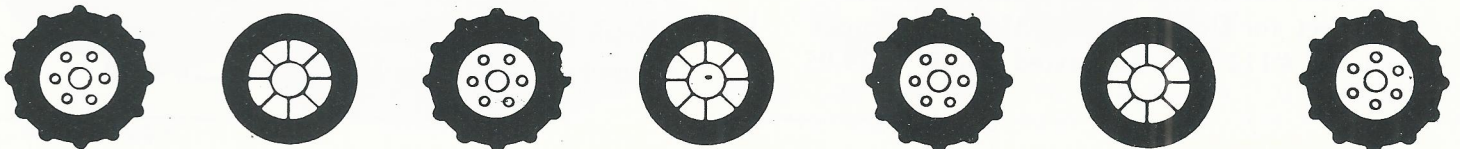

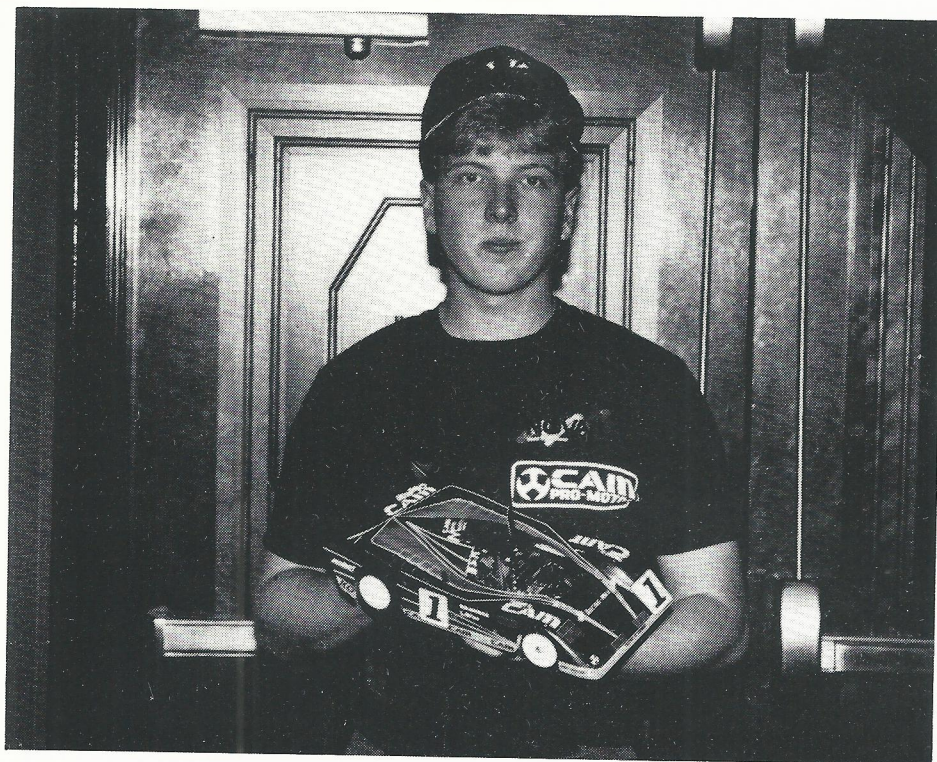

Chris Doseck was the TQ in Modified at the 4-Cell Nationals.

spot with a 39, 8:01.70. Chuck Sommers improved his first round time, but still dropped back to third with a 39, 8:02.95. At this point it took a 39, 8:17.86 to get into the A Main.

Round three was the fastest round for the Stockers. This was the round we saw the 40 lap barrier fall by not only one driver, but two. Of course, one driver was the current TQ, Jon Orr. Jon never let his TQ spot go to anyone else. Jon's 40 lap run was a 40, 8:11.37. Chuck Lonergan had the second 40 lap run with a 40, 8:12.19 less than a second off the TQ time.

There were no more 40 lap runs in the fourth round. Jon Orr was going to be the TQ for this year's 4-Cell Nationals in the Stock Class. Chuck Lonergan secured second, and Scott Nelson moved into the third qualifying spot by turning in a 39, 8:01.22. Jon Orr ran strong and consistent through qualifying all weekend. It seemed that Jon was the one to beat.

Modified Qualifying

Many of the top drivers in the

world were on hand to compete in the 1990 Trinity ROAR 4-Cell Nationals. Winning this race was going to be no cake walk, with drivers like Trinity's Joel "Magic" Johnson, Tony Neisinger and Bob "Bullet" Light. Cam Motor's Chris Doseck and Peak Perform-

mance's own Rick Hohwart. Qualifying was going to be very intense. Joel started things off on a high note as he turned in the fastest time of round one. Joel's Trinity powered Corally turned in a time of 43 laps, 8:09.58. Rick Hohwart was the second fastest in round one, but was not nearly on the same pace as Joel. Rick's time was only 42, 8:06.33. At this point it looked like Joel would be the one to beat.

In round two Chris Doseck turned up the boost in his Cam powered 12L and took the pole away from Johnson. Doseck's time was a 43, 8:07.95. Johnson's first round time kept him second on the grid. Louis LeBlanc turned in the fastest 42 lap run with a 42, 8:00.44 to give him third position. Hohwart improved his first round time to 42, 8:02.87, but dropped from second to fourth on the grid.

Round three had yet another driver turn 43 laps. This time it was Trinity's Bullet Man Bob Light. Bob's time was slower than Joel's and Chris' but a 43 lapper nonetheless. This run put Bob third on the grid with a time of 43, 8:14.18. This was the only significant run of this round.

Leading Edge

R/C Racing Products

Battery Power To Win
 \$\$ PRICED TO SELL \$\$
 Sanyo - Lavco Matched

SCEs		SCRs	
Lavco #	\$/Cell	Lavco #	\$/Cell
680+	10.00	490+	9.00
660-679	8.50	480-489	7.50
650-659	7.00	470-479	7.00
640	6.00	460	6.00

Available At
 Action Pro Shop
 (313) 283-8322

or
 See Your Local
 Hobby Dealer

• Dealer Inquiries Invited •

Leading Edge - 3224 Fourth Street, Wyandotte, MI 48192



5 National Titles

YOU CAN'T BEAT THE SYSTEM

- **VRP LUBRISYSTEM**, a unique lubricating system featuring VRP's 4 superior lubricants at an economical price!
- **LUBRISPRAY**, the only spray synthetic lubricant designed for R/C car transmissions. We couldn't make it any simpler. Just spray it in . . . and win.
- **LUBRIBEARING**, a new ballbearing grease that goes on thin, seeping into all crevices and other moving parts. The carrier then evaporates leaving behind a thin layer of grease that won't fly out.
- **LUBRITooth**, for use on teeth of all gears. Lubritooth is a bonding lubricant that dries quickly forming a permanent lubrication that won't attract dirt.
- **LUBRIDIFF**, a high tech synthetic grease for use on all ball type diffs. Very high traction coefficient allows the diff balls to grip the rings without unnecessary tightening.



Available at your local Hobby Shop.
Or call toll free 1-800-783-4VRP
Mon. thru Fri. 9 to 5 Eastern Standard Time

verona racing products

4555 Groves Rd. #15 • Columbus, Ohio 43232
Telephone: 614-861-4555 • Fax 614-861-4050

SASE for Brochure and Tech Tips
add \$2 for decals, add \$10 for T-shirt (size)

The fourth and final round is normally where you see the blistering runs, as by now the drivers should have their cars dialed in, plus the good stuff in their cars. Unfortunately there were no 43 lap runs in round four. Rick Hohwart and his Peak Performance powered 12L made a gallant effort at the 43 lap barrier, but fell about a half second short. Into the main it was going to be Chris Doseck and his Cam powered 12L on the pole. Next to him would be rival Joel "Magic Johnson and his Trinity powered Corally. Two different power plants, two different chassis, but two very similar times.

Stock A Main

Going into the A Main your favorite had to be Jon Orr. Orr was consistently fast all weekend, and with a great start, was going to be almost invisible. Orr's wish was granted at the tone starting the race. He immediately jumped into the lead followed by Lonergan, your second TQ and Bill Schoenau in third. Bill started back in eighth and was now in third. Orr and Lonergan started to stretch from the field. Orr must have felt the pressure from Lonergan as he spun and let Lonergan go by. Into the third spot was now Jack Kloeber, about 50 feet behind. Orr regained his composure and began to pressure Lonergan, but before he had a chance to repass Orr's car turned sharply into the sweeper wall and was incapacitated. I am unaware of what exactly happened but it appeared that Orr had a little radio glitch or perhaps a bad steering servo that lead him into the wall to end his quest for victory. With Orr out Lonergan was looking at a comfortable lead over your second place car of Jack Kloeber. Kloeber also had a comfortable lead over third place. The battle for third place was the best one on the track between Chuck Sommers and Bill Schoenau. At the 3:30 mark Sommers began to

stretch it out a bit over Schoenau and had his sights set on Kloeber for second. At the four minute mark Lonergan had about a half lap lead and began to put it on cruise mode. Sommers started to close in on Kloeber for second. At the six minute mark Kloeber started to reel Lonergan in a bit, but still had a lot of real estate to cover in two minutes. Meanwhile Sommers closed up to about 10 feet on Kloeber for second place. Sommers was giving it a gallant effort, but could not close up and tighten the gap to make a move for a pass. When the eight minute mark was up it was Chuck Lonergan taking the win followed by Jack Kloeber in second and a hard charging Sommers in third. Chuck Lonergan became ROAR's first 4-Cell National Champion in the 90s.

Modified A Main

Before the start of the A Main, there was some concern as to the health of the TQ, Chris Doseck. It appears Chris was a little under the weather when he woke up on Sunday morning. We will have to wait and see how it affects his performance. The horn sounded and Doseck got the hole shot followed by Bob Light and Rick Hohwart. Doseck's

lead was short lived as in the second turn Doseck turned in about six inches too soon and stuffed it. Rick Hohwart made an aggressive move to the inside and took the lead. Light had to put on the brakes to avoid Doseck and fell back to fourth. Hohwart put his Peak Performance motor in overdrive and motored away. Joel Johnson moved into second and Joe Lawrence into third. By the first four laps Hohwart had established a comfortable lead over Johnson. Joel had to contend with the up and coming Joe Lawrence, who was driving like a man possessed in third. Doseck regained his composure and moved into fourth. Lawrence hung on Joel until about the two minute mark, where his charge would end when Joe crashed. Doseck was now in third and closing on Johnson.

At the four minute mark it looked like Rick would have things his way barring any battery or traffic trouble. Rick was going flat out and flying. Doseck had another mishap and fell victim to Scott Smith. Smith had inherited second when Joel had a date with a backmarker and fell back to third. With Johnson's misfortune Doseck closed back up on him and the two started to stalk Smith for second. Within a

THE CONTROL ROOM

RC is Red Hot!

Full Color

POSTERS, DECALS, SHIRTS, ETC...

For more information ask your Dealer
Or send self addressed stamped envelope
to THE CONTROL ROOM: 1334-D N Benson Dept. C
Upland CA 91786 714-987-3838 714-985-9700

HobbyShopper's Guide

R/C MODEL RACE CARS
1/10, 1/8, 1/12 scale
Electric, Gas



KIT CAR
"WE RACE WHAT WE SELL"

Specializing in complete racing units and parts.

Dave Bressel (503)256-9916 Shop/Mail Order
Byron Bressel 12010 NE Glisan, Portland, OR 97220

Radio Control - Plastic Kits - Crafts - Model Railroading



COMPLETE LINE OF R/C RACE CARS & ACCESSORIES
903 FAIRYLAND ROAD
ACROSS FROM FRANKLIN TOWNSHIP BUILDING
LEHIGHTON, PENNSYLVANIA 18235
(215) 377-2402

Lake Side HOBBY SHOP



Specializing in R/C Cars
large stock of accessories!

BENEFIT FROM THE EXPERIENCED RACERS!!

We ship UPS 13737 N DALE MABRY
LAKE SIDE CENTER
TAMPA, FLA 33618
PHONE (813) 961-9432

major credit cards accepted



WALT'S HOBBY

Full line radio control hobby shop specializing in friendly, helpful service for remote control cars, parts and accessories. Daily UPS Service. Discount Prices. Visa, Master Card, American Express. Home of the indoor clay oval and computerized scoring.

"CALL WALT'S"

Tel. (315) 453-2291

2 Dwight Park Dr.
Syracuse, NY 13209

BUFFALO, NY

When Visiting Niagara Falls - Visit Us Too
I-90 Thruway Exit 52 E (Near Galleria Mall)

Niagara Hobby & Craft Mart

3366 Union Rd. (at Walden), Buffalo, New York 14225
R/C Cars - Parts & Accessories
Our **OVAL BLACKTOP** R/C Track Open Saturdays & Sundays

716-681-1666 OPEN EVENINGS AND SUNDAY

RC PIT STOP

#14-6822 128th St., Surrey, B.C. V3W 4C9



Radio Controlled Models
Cars, Parts and Accessories

WES TURNBULL (604) 597-4670

HobbyTown
*Where your dreams live**

NEBRASKA		Colorado Springs	719-531-0404
Lincoln	402-483-7427	CALIFORNIA	
Lincoln	402-464-2858	Encinitas	619-942-2014
Lincoln	402-476-3829	Escondido	619-739-0672
Omaha	402-391-5669	OHIO	
Bellevue	402-291-0542	Cincinnati	513-793-5112
Grand Island	308-382-3451	VIRGINIA	
Scottsbluff	308-635-7001	Centreville	703-818-3069
COLORADO		Manassas	703-551-2700
Fort Collins	303-224-5445	ARIZONA	
Denver	303-431-0482	Scottsdale	602-948-3946

** CALL FOR LOCAL INDOOR AND OUTDOOR RACE TIMES **
YOU CAN OWN YOUR OWN STORE JUST CALL 402-467-4784





STRONGSVILLE HOBBY SHOP

NORTH COAST R/C MAIL ORDER HEADQUARTERS
CALL FOR MAIL ORDER SPECIALS

13325 PROSPECT ROAD
STRONGSVILLE, OH 44136
216-572-0430

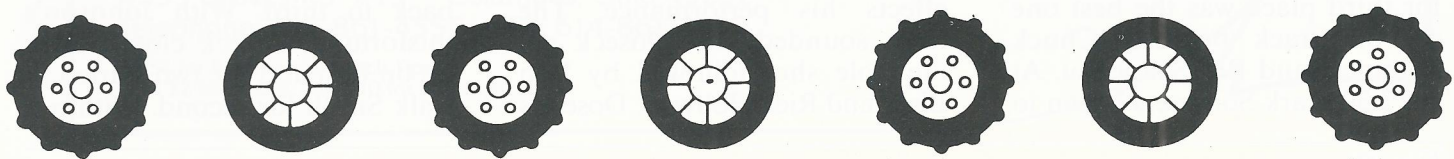
JERRY IVANCIC



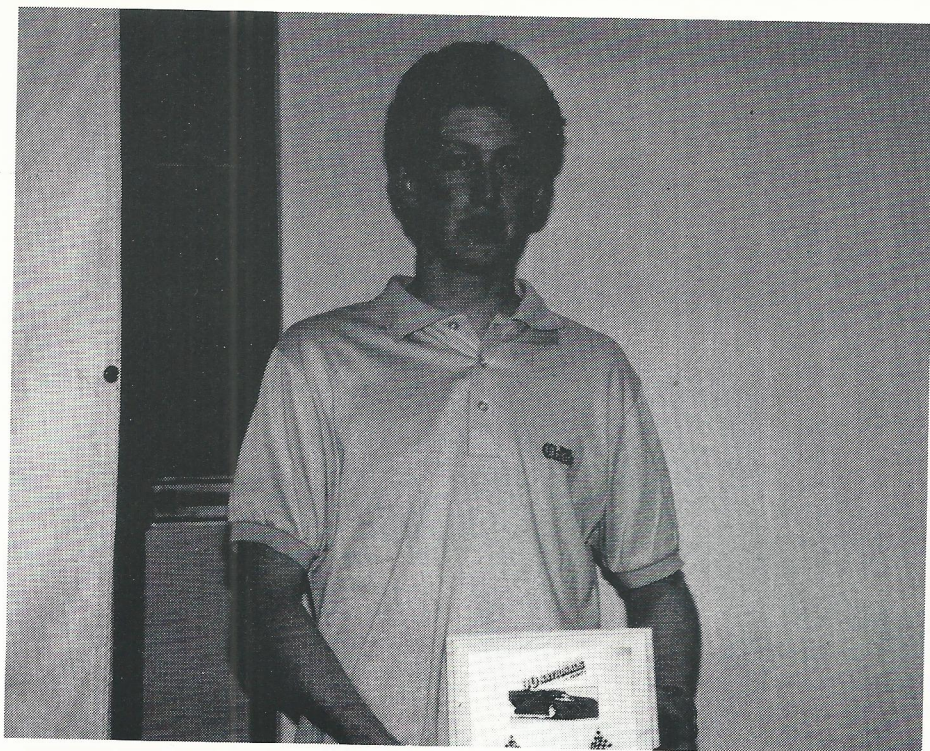

Jon Orr was the TQ in the Stock Class.

lap and a half Joel was up on Smith's bumper. This is when things started going wrong for Joel. Joel tried repeatedly to get by Smith, but with no avail as Smith shut the door each time. With each turn being behind Smith, Hohwart stretched his lead just that much more.

Finally, Joel had to make a move and commit himself. He did just that and got tangled with Smith. This put Doseck in second and Johnson in third. At this point there was a little over two minutes left and Hohwart started to conserve batteries. Doseck was out of striking distance. The man that had wings on was Joel Johnson. After the mishap with Smith, Joel must have traded his driver's license for a pilot's license. Joel was flat out flying. It didn't appear that Joel had time to catch Hohwart, but Doseck might be a different story. Johnson was competing for the Triple Crown and every position was crucial for him. At the seven minute mark Johnson had closed up some on Doseck, but he still had a way to go. Hohwart's batteries with a

minute to go, still seemed to be fairing well, along with Doseck's and Johnson's.

In this last minute Johnson must have realized that all he had to do was beat Louis LeBlanc to take the Triple Crown, as he started to ease up and make sure his batteries would last and didn't hit the throttle as hard after Doseck. Doseck closed in on Hohwart, but time was his worst enemy. At the eight minute mark it was Rick Hohwart and his Peak Performance 12L winning it from the second turn to the finish. Hohwart must not have let up too much as his A Main winning time was a hole seven seconds faster than the TQ time. That's incredible in a main event with ten cars. Chris Doseck took second and Joel Johnson was awarded third.

Joel's third position gave him enough points to win the prestigious Sanyo Triple Crown title. My congratulations go out to the two Nationals Champions, Chuck Lonergan and Rick Hohwart, and the Sanyo Triple Crown Champion Joel "Magic" Johnson.



**"Your Power Source
for
Batteries & Motors"**

**NEW
MOTOR TECHNOLOGY**

Terry Riley's Texas connection has developed a line of R/C motors to give you the competitive edge!

Texas Pride goes into the preparation of each motor. Each motor uses advanced R & D computer and custom-made dyno to insure each motor to highest quality & performance.

**TEXAS
CONNECTION**

P.O. BOX 1449 • 106 E. MAIN
VAN, TX 75790

Phone (214) 963-5729 Fax (214) 677-1503

Send FREE motor tips

Enclosed \$4.00
Send latest catalog.

Enclosed \$25.00
Send new motor
(new offer only)



NAME _____

CITY _____ STATE _____

ZIP _____ PHONE _____

At this point, on behalf of the racers and organizers, I would like to thank Trinity Products for their national sponsorship support. Thanks to John Thawley and the entire SEMROCC Club for another fine event. We are looking forward to the 1991 IFMAR World Off-Road Championships to be hosted by SEMROCC.

See you at the next Nationals!
MODIFIED MAINS
A Main

JG'S BOLT-ON ADVANTAGE

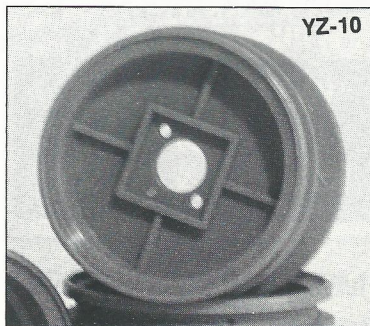

DIRECT BOLT-ON MONSTER TRUCK RIMS

These "new" dyable nylon rims are ultra lightweight for less unsprung weight. Front rims use stock bearings and axle nuts, rear rims use stock axle nuts. Booth front and rear rims are ribbed across back for super strength.

- 1453 RC-10 Front Nylon Direct Bolt on Rims.
- 1454 RC-10 Rear Nylon Direct Bolt on Rims.
- 1455 Kyosho Front Nylon Direct Bolt on Rims.
- 1456 Kyosho Rear Nylon Direct Bolt on Rims.
- 1457 YZ-10 Front Nylon Direct Bolt on Rims.
- 1458 JRX2 Front Nylon Direct Bolt on Rims.
- 1459 JRX2 Rear Nylon Direct Bolt on Rims.

Set of Two: \$6.95

NEW! 4-COLOR PACKAGING FOR JG MONSTER TRUCK CONVERSION KITS.



NEW 1990 CATALOG!

For the latest Monster Truck, On & Off Road conversions, tire parts and accessories send \$3.00 cash or money order.



John gudvangen manufacturing

P.O. Box 6014, Whittier, CA 90609-6014
(213) 947-1206 FAX: (213) 693-2577

- 1st - Rick Hohwart
Assoc. 12L/Peak Performance
- 2nd - Chris Doseck
Assoc. 12L/Cam
- 3rd - Joel Johnson
Corally/Trinity
- 4th - Louis LeBlanc
Agitator/Twister
- 5th - Mike Blackstock
Assoc. 12L/Reedy
- 6th - Bill Jeric
Agitator/Twister
- 7th - Joe Lawrence
Agitator/Peak Performance
- 8th - Bob Light
Corally/Trinity
- 9th - Bob Schoenau
Corally/Twister
- 10th - Scott Smith
Assoc. 12L/RevTech

B MAIN

- 1st - Tyree Phillips
- 2nd - Mike Seubert
- 3rd - Frank Calandra
- 4th - Mike Ebert
- 5th - Tony Neisinger
- 6th - Chad Coppock
- 7th - Barry Baker
- 8th - Carl E. Christy
- 9th - Andy Dobson
- 10th - Ron Ferguson

C MAIN

- 1st - Dan Louis
- 2nd - Tom Lamb, Jr.
- 3rd - Glenn Tonagai
- 4th - Jim Hoffman
- 5th - Steve Verona
- 6th - Wayne Gerber, Jr.
- 7th - Glenn Ornat
- 8th - Dwight Smith
- 9th - Jason Temme
- 10th - Terry Rott

D MAIN

- 1st - Jeff O'Malley
- 2nd - Mike Marshall
- 3rd - Mike McBride, Jr.
- 4th - Ryan Moore
- 5th - Chris White
- 6th - Lance Elbertson
- 7th - Ralph Duncan
- 8th - Paul Brower
- 9th - Paul Cameron
- 10th - Keith Hamilton

E MAIN

- 1st - Peter Fitch
- 2nd - Steven Mancinelli
- 3rd - Boyd Gaebel
- 4th - Tom Lamb
- 5th - John P. Adams
- 6th - Jeff Travelstead
- 7th - Peter Peterson
- 8th - Mike Setwart
- 9th - Bob Novak
- 10th - Steve Radecky

F MAIN

- 1st - Tony Mancinelli
- 2nd - Keith Mason

- 3rd - Jay Tharp
- 4th - Tony Coello
- 5th - Frank Calandra, Sr.
- 6th - Michael Coello
- 7th - James R. Parton
- 8th - Brad Melone
- 9th - Chuck Pfahler

STOCK MAINS

A MAIN

- 1st - Chuck Lonergan
Assoc. 12L
- 2nd - Jack Kloeber
Delta
- 3rd - Chuck Sommers
Assoc. 12L
- 4th - Scott Nelson
Assoc. 12L
- 5th - Bill Schoenau
Corally
- 6th - Aaron Treppa
Corally
- 7th - Bill Worrel
Corally
- 8th - Scott Williams
Assoc. 12L
- 9th - Bob Joysey
Assoc. 12L
- 10th - Jon Orr
Corally

B MAIN

- 1st - Steve Boice
- 2nd - James Arnold
- 3rd - Stan Naymola
- 4th - Darryl Bingner
- 5th - John G. Pens
- 6th - Joseph W. Fitzpatrick
- 7th - Jim Keserich
- 8th - Dean Smith
- 9th - Willy Decker
- 10th - Frank Boling

C MAIN

- 1st - Andrew Power
- 2nd - Jay Regan
- 3rd - Sean Maybell
- 4th - John St. Amant
- 5th - Mark T. Gorney
- 6th - Leo Barana
- 7th - Jason Harder
- 8th - Dave Smaltz
- 9th - Kevin Montalbano
- 10th - Jim Piper

D MAIN

- 1st - Ralph Herndon
- 2nd - Mike Becker
- 3rd - Dave Berry
- 4th - Blayne Arndt
- 5th - Peter Maiolo
- 6th - Rick Rottach
- 7th - Tom Joysey
- 8th - David E. Loreski
- 9th - Ted McCarthy
- 10th - Carrie Gerber

E MAIN

- 1st - Mark Calandra
- 2nd - Chuck Mackin
- 3rd - John K. Hedeon, Jr.
- 4th - Neal Everhart

THRILL

OR BE THRILLED?



THE JR-XT SWEEPS THE 1990 R.O.A.R. NATIONALS!

- FACT:** 19 out of 20 cars in the "A" mains were Team Losi trucks.
- FACT:** 1st, 2nd, 3rd and T.Q. modified were all powered by Revolution Motors.
- FACT:** The JR-XT has won EVERY N.O.R.C.C.A. and R.O.A.R. Monster Truck National Championship.

THE JR-XT... "A THRILLER WITH A RECORD!"

There is a monster on the loose devouring it's competition . . . The JR-XT Racing Monster Truck. Utilizing race proven JR-X2 technology, this reasonably priced kit includes the right parts that make it a relentless winner "out of the box." Winning every U.S. National Championship event in 1989 and 1990 is proof enough!



Team Losi makes it easy . . . check out these features: race tuned 5 link suspension with long-travel oil filled shocks - front and rear, L.R.M. transmission, rigid graphite composite fiber chassis, "H.T." compound "Naturals" Rubber Racing Tires with lightweight reusable wheels designed to not pack with dirt, high impact shock absorbing body mounts/skid plate, preformed interior dirt shields, spoiler, & number panels, pre-cut window masks and the "HOTTEST" looking super tough Lexan body with full color sticker sheet.

OUR RECORD IS CLEAR!

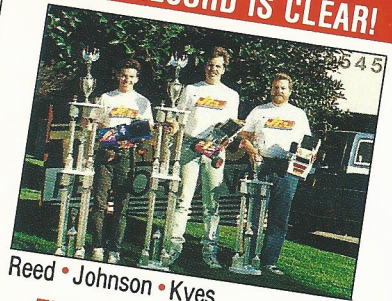

Reed • Johnson • Kyes

THE JR-XT SWEEPS THE 1990 R.O.A.R. NATIONALS!

- STOCK:** 1st — Jack Johnson
2nd — Scott Brown
3rd — Kyle Reed
T.Q. — Jon Anderson
- MODIFIED:** 1st — Kyle Reed
2nd — Jack Johnson
3rd — Gary Kyes
T.Q. — Jack Johnson



TEAM LOSI • 1655 E. MISSION BLVD. • POMONA, CA 91766 • (714) 620-0164

NEW FROM:

SRS

S HOCK CASES

These strong lightweight shock cases eliminate oil contamination. Sold in 3 sizes: 71, 102 & 132 stroke.

S HOCK CARTRIDGES

Precision machined replacement cartridges put an end to leaking on your Losi shocks. Internal pressurization chamber not needed as an air free shock seal is obtainable.

W RENCHES

Featuring a long screwdriver handle and hardened replaceable tip. Guaranteed not to round off. Will reach cap screw from an angle.

Y OKOMO BULKHEADS

This billet machined bulkhead is extremely break resistant and lighter than stock. Retains factory caster setting.

Y OKOMO HUBS

These super strong hub replacements features spaced bearing pockets that increases axle support and a tighter bearing fit.

While adding a High Tec look to your racing vehicle, Uses existing stock parts internally. Requires an SRS shock seal for a leak proof cap.

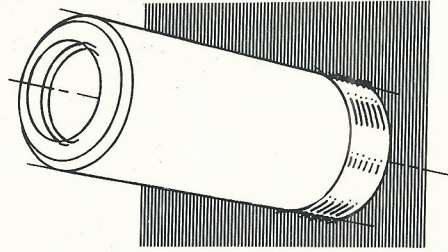

Use as shock rebuild kits. Featuring a double O ring seal.

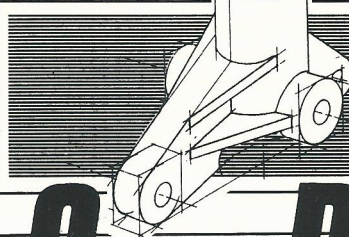
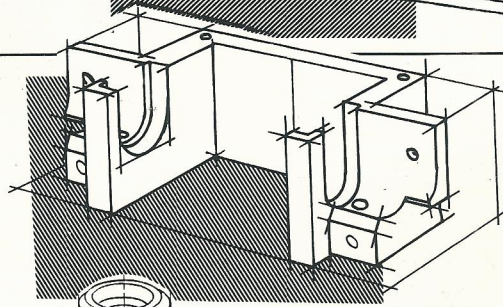
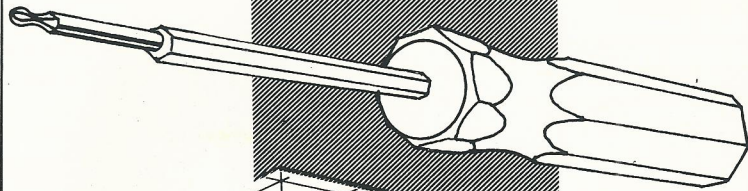
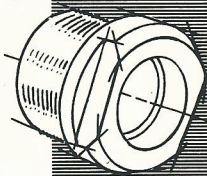

Reducing slop also allowing you to use either a flanged or non-flanged 5x10 bearing.

Scale Racing Sports

1120 N. Hayden Road • Tempe, AZ 85281 • (602) 829-9117

Distributed by: • Horizon Hobby Dist. 1-800-535-5551
• ERI Dist. (914)-268-5090 • RCS Dist. (408)-943-0874
• RPS Dist. (914) 620-0164 • Speed Sport Dist. (714) 995-4460

5th - Scott Moody
 6th - Derek Smith
 7th - Joe Weeman
 8th - Keith A. Tessmer
 9th - Brent Owen
 10th - Bruce Owen

F MAIN

1st - David A. Lee
 2nd - Richard DeZéuw
 3rd - Mathew Stinson
 4th - Mike Carter
 5th - Larry Rice, III
 6th - Larry Wodell
 7th - Robert Shuchman
 8th - Dick Baker
 9th - Brian Bury
 10th - Wilkie Wilkinson

G MAIN

1st - Joshua Cyril
 2nd - Vicky Carrubba
 3rd - Ron Shonk
 4th - Kirt Scammell
 5th - John Schweitzer
 6th - Ronald A. Kwentus
 7th - Greg Reed
 8th - LLoyd Leichentritt.
 9th - Jim Clark
 10th - Gregory Geibel

H MAIN

1st - Jerry Cyril
 2nd - Reed Bolick
 3rd - Rick Goodman
 4th - Ned Smaltz
 5th - Scott McKeighan
 6th - Dave Lawson
 7th - David Zimmerman
 8th - Mike Alexander
 9th - David Wartell
 10th - Brian Berry

**Be a
 winner with
 Hyperdrive**
Racing Systems

Hyperdrive kits and accessories are available through popular hobby shops and distributors.

For parts, catalogs (\$3) with free stickers, or more information, call factory direct.

3210 Howard Nickell Road • Fayetteville, Arkansas 72703
 Phone (501) 444-8200 or (501) 444-8494
 Fax (501) 444-8402

Don't Make

A Move

Without Us!

Subscriber: Please notify us of your new mailing address four weeks prior to moving.

ARISTOTLE THROTTLE

PRESENTS

THE

PHILO

ELECTRONIC SPEED CONTROL

ARISTOTLE THROTTLE has been repairing, upgrading and tuning electronic speed controls for competition in the Pacific Northwest for two years; and has now combined that experience to make what may be the **HOTTEST NEW SPEED CONTROL** on the market today!

SPECIFICATIONS:

- Current Capability: 360 Amps
- Voltage Drop: .002 Volts/Amp
- Weight: 1.6 ounces
- Size: As small as possible
- Throttle Linearity: Nearly Perfect

THREE MODELS AVAILABLE:

1. **PHILO IHS** - Low Torque
2. **PHILO IHN** - High Torque
3. **PHILO FHG** - Marine

All Three Share the Same Specifications

These speed controls are designed specifically for racing applications only and are available now direct from **ARISTOTLE THROTTLE**. Each unit is numbered and registered in the purchaser's name.

TO ORDER YOUR PHILO:

CALL ARISTOTLE THROTTLE AT **206-776-8968**

OR MAIL TO:

ARISTOTLE THROTTLE
 9792 Edmonds Way, Suite 166
 Edmonds, Washington 98020

Include your check or money order for \$99.95 + \$6.00 for shipping and handling for the low and high torque models, or \$149.95 + \$6.00 for the marine model.

For a limited time **ARISTOTLE THROTTLE** will allow a \$10.00 trade-in allowance for your Tekin or Novak Esc, working or not.

P.S. Aristotle Throttle Also repairs, upgrades, and tunes Tekin and Novak ESCs.

Repairs: \$20.00 + Parts, Shipping and Handling
Upgrades: \$45.50 and Up + Shipping and Handling
 (Includes STAGE III wire)

And for you Monster Truckers and Tractor Pullers, we have a mod that will give you tons of power in both forward and reverse with twin modified motors. Call us with your special application.

Find Out How Good You REALLY Are!



Trinity **PUSHED** Cells... The Winning Difference

The days of winning without PUSHED batteries are over. Guys like Joel "Magic" Johnson®, Tony Neisinger, Bob Light and Andy Dobson know that. Batteries are that important edge. That's why Trinity PUSHED cells are cycled through our computerized charging and conditioning sequence.

Trinity's special PUSHED conditioning increases the battery's capacity, voltage output and run-time. Our computer analyses each cell and prints the results right on the label.

You know you are good. The question is, "How good?" Eliminate all doubts. Use Trinity's hottest cells and find out.

0359	1.09	Run-time at discharge rate
5.00	20.0	Average volts during discharge
Trinity PUSHED Cells		Discharge rate (amps)
		Peak charge rate (amps)

Battery Label

SCR			
4-Cell	#5500	\$39.99	
6-Cell	#5501	\$59.99	
7-Cell	#5502	\$69.99	
SCE			
4-Cell	#5503	\$48.00	
6-Cell	#5504	\$67.00	
7-Cell	#5505	\$77.00	

TRINITY Trinity Products, Inc.

1901 E. Linden Ave., #8, Linden, NJ 07036
(201) 862-1705 • FAX: (201) 862-6875

Trinity® Battery Rematching Service
Are your battery packs becoming weak? Send in your used cells and have them rematched. 48 cell minimum. Cells must be free of braids, solder, etc. \$1.50 per cell thru your local hobby shop, which also has further info on the service.



TRASH THE COMPETITION!



The ALL NEW
Speedworks

TRIAD SERIES HAND WOUND, MODIFIED MOTORS

- Hand wound, modified armature
- Adjustable timing
- Composite, hi-temp endbell material
- Brush heat sinks
- Precision ball bearings
- 2-stage wet magnets. 4.0

\$59.99
*ROAR
LEGAL!*

50,000 rpm 9 turns #0666	49,000 rpm 10 turns #0667	46,000 rpm 11 turns #0668	43,000 rpm 12 turns #0669	41,000 rpm 13 turns #0670
--------------------------------	---------------------------------	---------------------------------	---------------------------------	---------------------------------

**"NOW YOU DON'T HAVE TO SPEND
A FORTUNE TO FINISH ON TOP"**



Trinity Products, Inc.

1901 E. Linden Ave., #8, Linden, NJ 07036 • (201) 862-1705 • FAX: (201) 862-6875

NORRCA

NATIONAL ORGANIZATION FOR RACING RADIO CONTROL AUTOS

1990 OFF-ROAD NATIONALS

JULY 6TH - 8TH DALLAS, TX

HOSTED BY NORM'S R/C HOBBIES

PRESENTED BY

TEAM LOSI PERFORMANCE

NORRCA MEMBERSHIP IS REQUIRED * (MEMBERSHIP IS AVAILABLE AT TRACK OR THROUGH NORRCA) * NORRCA RULES APPLY * NORRCA OFFICIALS WILL BE PRESENT * SHIRTS FOR PRE-ENTRANTS ONLY * NORRCA T.Q. PINS & TROPHIES FOR TOP QUALIFIER IN EACH CLASS * TROPHIES 1st-10th IN ALL "A" MAINS * 1-3 ALL MAINS * CONCOURS TROPHIES 1st-3rd * TROPHY DASH FOR EACH CLASS * HOST HOTEL IS THE "DALLAS RADISON" 2330 W. N.W. HWY, DALLAS, TX 75220, 214-351-4477 * YOU MUST ASK FOR THE NORRCA RACE RATE * AIRPORT AND RESTAURANTS NEARBY * 3RD ANNUAL NORRCA TEAM CUP CHALLENGE -THE TEAM WITH THE HIGHEST OVERALL POINTS WILL BE AWARDED A GOLD CUP FOR "THE BEST OFF-ROAD TEAM" OF 1990 * ENTRIES LIMITED TO 400. PRE-ENTRIES CLOSE JULY 1ST * ENTRIES DAY OF RACE IF AVAILABLE \$50.00 * STOCK MOTORS WILL BE SUPPLIED * ADDITIONAL MOTORS WILL BE \$15.00

SCHEDULE: JULY 5TH PRACTICE ALL CLASSES 10AM-6PM * 6TH 6AM -8AM CHECK-IN, 8:30 1ST HEAT, 2:00PM BEGINS 2ND ROUND, JULY 7TH 7:30AM CONCOURS, 8:00 AM 3RD ROUND, 2:00PM 4TH ROUND, JULY 8TH 8-9 AM TROPHY DASH, 9:30 START OF LOWER MAINS. ALL SCHEDULED TIMES ARE APPROXIMATE. SCHEDULE MAY VARY AND CAN BE ADJUSTED AT ANYTIME *

TRAXXAS

***** ASSOCIATE SPONSORS *****



LC Sidewinder

Bullet Racing Products



CHU F.G. HOUSTON, TEXAS

CRM RACING INC.



MANUFACTURING



B&B SOFTWARE AUTOSCORE

SHIRTS DESIGNED & PRINTED BY D.J. RENWICK

NATIONAL CHAMPION RACE CASES WILL PROVIDED BY ADVANCED RACE CASE

NORRCA OFFICIAL 1990 OFF-ROAD NATIONALS ENTRY FORM

NAME _____ EXPERT _____ SPORTSMAN _____ PHONE _____

ADDRESS _____

CLASS(ES): 2W STOCK _____ 2W OPEN _____ 4W STOCK _____ 4W OPEN _____ OPEN TRUCK _____

SUPER STOCK TRUCK _____

2W FREQUENCIES 1. _____ 2. _____ 3. _____ SPONSOR(S) _____

4W FREQUENCIES 1. _____ 2. _____ 3. _____ CAR _____ MOTOR _____ RADIO _____

ENTRY FEE: \$35.00 1ST CLASS., \$25 EA ADD'L CLASS. EACH STOCK ENTRY \$40.00 (INCLUDES 1 MOTOR) NO ENTRY REFUNDS. SEND ENTRY & CHECK PAYABLE TO: NORRCA, 1530 W. 8TH ST #117, UPLAND, CA 91786 FOR ADD'L INFO. CALL NORM'S AT 214-357-3453 OR NORRCA AT 714-981-9641

NORRCA # _____

1990 Festival of Racing Winter Championship

By John Thawley

Once again 1/12 scale Four Cell enthusiasts descended on Grand Rapids, Michigan for this spectacular Winter Championship. This race without a doubt has to be one of the finest races anywhere. The Rivertown Racers continually manage to outdo their previous efforts and deliver a first class quality event. I repeat, this is the finest event anywhere.

The track design was extremely challenging. Maybe a bit too much so for Novice. But as they say it was the same track for everyone and some very respectable names were brought to their knees. (I'll never race in shorts again).

Scoring was done once again with the aid of Don Holub's Pro Score Race Management Program. Head wizard Don Holub was at the helm with the assistance of the ever astute Linda Carruba. Needless to say the pair performed the task with remarkable results. ie. Accurate!

The Stock field was huge. About 140 drivers had come to display their skills in this ever popular class. With one round of qualifying down the cream immediately began to rise to the top. Chuck Lonergan let his presence be known with the only 39 lap run of round one.

The big question throughout the Modified camps was that of how much horsepower could this twisting circuit handle? The



Keith Hamilton (left) and Joel Johnson (right) the Stock and Modified winners of the Winter Championship.

answer was instantly delivered to the crowd favorite and two time Winter Championship winner, Chris Doseck put down the only 42 lap run of round one.

In round two of Stock, Lonergan improved his time by a couple of seconds but things were tightening up behind him. Pens, Schoenau, and Orr had also entered the realm of 39 laps.

Modified drivers in round two must have still been dazed by Doseck's early run has no one in the top three, including Joe Lawrence and Louis LeBlanc improved their times. However, Bill Jeric picked up the fourth slot followed by a whole gang of 41 lap runs. Things were definitely picking up throughout the field.

Round three of Stock saw

Pro Auto Peak - \$34.95

A Revolutionary Concept in Charging Technology

Δ Peak Detection Converter

- Instantly Converts ANY DC. Fast Charger (even charge cords) to a Peak Detection Charger
- Provides Increased Power & Run Time
- 100% Safe and Automatic
- Compact Size 3x2x1 1/4"

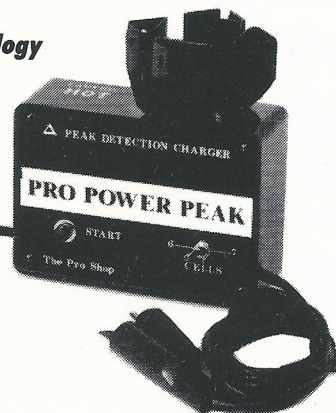
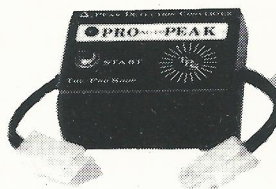

Both Units Feature:

- Use with Cars, Boats, Planes
- Tamiya Connectors
- One Button Operation
- LED Indicator
- Electronic Detection Circuitry
- Built In Self Test Routine • Automatic Switch to Trickle Charge

Pro Power Peak - \$49.95

- Self Contained DC. Peak Detection Charger for 6 or 7 Cells
- Transistor Current Regulator
- Pulsating LED Charge Indicator

Available thru local dealers or from The Pro Shop, P.O. Box 5382, Parsippany, N.J. 07054
Include \$2.00 P&H-N.J. residents add 6% sales tax-check or money order only-no C.O.D.

Distributor Inquiries Invited

NEW • EXCLUSIVE • NEW • EXCLUSIVE

ULTRA-Seals frictionless sealed bearings

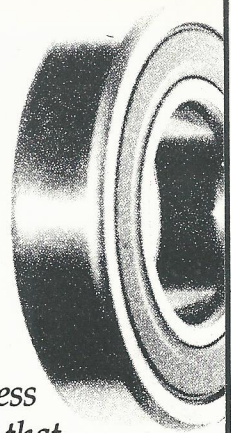

Goodbye DIRT & DUST

Boca Bearing are Frictionless Sealed, Maintenance Free Race Bearings that virtually eliminate Dirt & Dust. They've been racertested with tremendous results!!!

NOW AVAILABLE FOR RC10, TQ10, RC10/12L, JR-X2 ELIMINATOR 10/12, INVADER, PRO10 & OTHERS

BOCA BEARING ULTRA-Seals

Send \$3.00 for Bearing Guide and Further Information to:

7040 W. PALMETTO PARK ROAD, SUITE 2304, BOCA RATON, FLORIDA 33433

PHONE: (407)488-9606
FAX: (407)488-9609

NORTH AMERICA TOLL FREE
USA: 1-800-332-3256 / CANADA: 1-800-553-3256

Lonergan picking up insurance with another quick 39 lap run. Aaron Treppa jumped to the number two slot four seconds behind Chuck. One thing was for sure, if you had any notion of making the A main you had better have at least 39 laps or it would definitely be GAME OVER!

Just when Doseck thought it was safe to go out Mike Blackstock gunned him down with an outrageous 42, 8:03.42. A whopping 6 seconds faster than Chris's solitary 42 lap TQ run. Other than a little shuffling throughout the top twelve drivers in Modified things were rather quiet in the third round of Modified. However, Blackstocks's phenomenal TQ run created a lot of sleeplessness for most of the Modified camps.

Sunday morning brought the last round of qualifying. When the dust had settled from the fourth round of Stock it was obvious Lonergan was through

REEDY Modifieds

Reedy Modifieds Are Bursting Through With New Technology

Reedy Modifieds uses advanced R & D computer systems to develop and improve motor performance. Race developed and tested, Reedy motors are 4 TIMES IFMAR WORLD CHAMPIONS, leaping ahead of all competitors.

Reedy Modifieds. The Outburst of New Technology.

(Graph shown represents actual computer readout of Reedy Modifieds motor.)

CURRENT

TORQUE

POWER OUTPUT

OVERALL EFFICIENCY

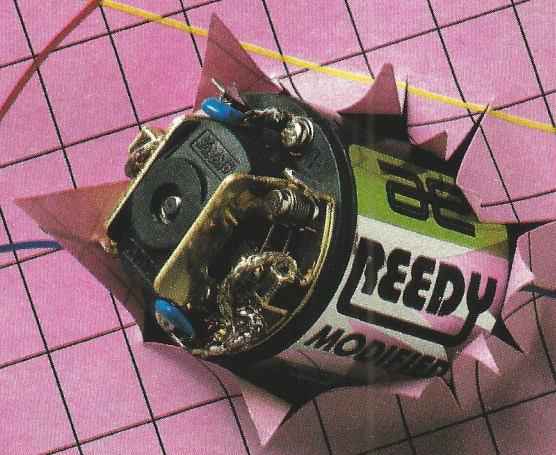

3585 Cadillac Ave.
Costa Mesa, CA 92626 USA

Phone (714) 850-9342 Telex 756887

FAX 714-850-1744



The Stock A Main Lineup.

fooling around. Chuck hammered (bad choice of words) out a genuine "Yeah Baby" 40, 8:12.83 TQ run. WOW!! The rest of the A set up with John Orr, Joe Fitzpatrick, Aaron Treppa, John Pens, Bill Schoenau, Jack Kloeber, Keith Hamilton, Dean Smith and Chuck "Endless" Sommers.

Modified drivers after a long restless night had to be content watching Blackstock's 42, 8:3.64 hold up to Chris Doseck's second best 42, 8:5.29, LeBlanc's 42, 8:7.15 and Magic Johnson's 42, 8:11.56. Joe Lawrence, Mike Suebert, Bill Jeric, Chad Coppock, Tony Neisinger, and Carl Christy all had 41 laps with less than six seconds separating them.

While the mains were being created the crowd was entertained by the "Bud's Kwazy Wabbit Wace". This event was a celebrity race of sorts using Volkswagen Rabbit bodies, CAM motors, and hand-out Power Push batteries. Since the race was surrounded by controversy, alleged bribing of race officials, and the disqualification of your humble reporter I will leave the reporting of this sordid matter to lesser distinguished publications.

Farfugnuten! Enough said! (thanks Joel).

The results of all the mains can be found at the end of this article. Here is what happened in the As.

The easy prediction for the Stock A Main was Lonergan wire to wire. For the first seven minutes one might have believed that. The field was reduced to 8 cars by the end of lap three. Treppa and Smith had dropped due to mechanical failure. Sommers who ultimately finished eighth was not a factor due to flat batteries. Schoenau who finished seventh was never really able to pull it all together. The shocker was Lonergan. Until the seven minute mark Lonergan was running a 41 lap pace. I would not have believed it had I not been at the timing table to see it myself. Unfortunately at the seven minute mark Lonergan fell off to a five lap pace and finished sixth. Pens was all alone in fifth. Kloeber finished fourth just one second behind Fitzpatrick in third. The top three cars, Hamilton, Orr and Fitzpatrick all finished within 1.5 seconds separating them. Congratulations to Keith Hamilton.

F&T
Racing Products

**GET IT
STRAIGHT
THE FIRST
TIME!**

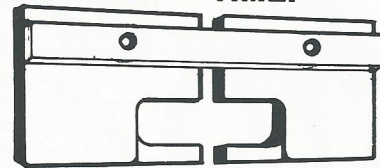

**NOW!!! GET THE SAME
BRUSH ALIGNMENT ON
YOUR STOCK MOTORS
THAT MODIFIED RACERS
HAVE ENJOYED FOR
YEARS. THE **F&T** Racing Products**

**"BRUSH HOOD ALIGNMENT
TOOL" LETS YOU
"BLUE PRINT" THE
ALIGNMENT OF YOUR
STOCK MOTORS BRUSH
HOODS TO EXACTLY 180°
APART.**

**FOR THE FIRST TIME YOU
CAN ADJUST
YOUR STOCK MOTORS
AND BRING THEM INTO
THE SAME SPECS THAT
THE ENGINEERS DESIGNED
THEM TO RUN.**

**DON'T BE LEFT
AT THE LINE.
ORDER YOUR'S
TODAY. \$**

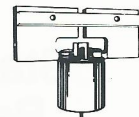

39⁹⁵

**SERIOUS PRODUCTS
FOR
SERIOUS RACERS**

**Winner's Circle is
F&T Racing Products
R&D Track.**

4320 Puddeldock Rd. (804)
Prince George, VA 23875 732-1210

Great race!

The fact that IFMAR type starts had been used for qualifying all weekend long made the starts of the mains that much more intense. After all this was the first time the drivers were seeing turn one together as a pack. Hole shot strategy vs crucial. The Trinity camp had instructed Magic to wait out the first corner. I anticipated Doseck to be conservative. I KNEW Blackstock would go for it. At the word go Blackstock held true to form,



CAL-ORE OFF ROAD CHAMPS

June 30 & July 1, 1990

Start the 90's racing in our Mountain Air and enjoy the Best Small Town 4th of July Celebration in California!

LOCATION: Mt. Shasta R/C Raceway, Lassen Lane & I-5, Mt. Shasta, California. Only 4 hours north of Sacramento or S.F. Bay Area, 5½ hours south of Portland. Call 916/926-4717 for more info or write.

ENTRY FEE: \$25.00 First Class (includes fluorescent Team Hat), \$10.00 Second Class

DEADLINE: June 25th, 1990

ROAR SANCTIONED

LODGING: Camping, RVs, Motels and Food Nearby.

THE TRACK: Mt. Shasta R/C Raceway 80'x130'. Computer Scoring with backup computer.

TROPHIES: All A-Main Drivers; Places 1 to 3 other Mains, Concours.

FORMAT: Sat. 12-5 Practice & Hot Laps Qualifying; Sun. 9-5 Heats & Mains.

CLASSES: STOCK (6 cells & ROAR STOCK MOTOR), MODIFIED (6 or 7 cells and Modified Motor); 2WD, 4WD, STOCK MONSTER TRUCK, MODIFIED MONSTER TRUCK.

Sponsored by:



ENTRY FORM

Due June 25, 1990

Checks Payable to: Dan's R/C Racing
Mail to: Mt. Shasta R/C Racers
826 Pine Street
Mt. Shasta, CA 96067

NAME _____
LAST FIRST

ADDRESS _____ PHONE _____

CITY _____ STATE _____ ZIP _____ ROAR # _____

CLASS 1) _____ Frequency 1st _____ 2nd _____ 3rd _____
 2) _____ (Red, Blue, 72, 64, etc.) _____

ROAR Membership Required Available at Track



The Modified A Main

Magic disobeyed team orders, and Doseck's conservatism left him caught up in the pack. Within the first few laps Professor Johnson had given Blackstock instructions on how to "Bust the Move" and he was literally gone! All that was left was to see if the Trinity camp had learned anything from their Turkey day dump at the Annual Cleveland class. The Magic Man with his Trinity/Corally combo continued his lead under the timing bridge at 7:59 and finished with a 43, 8:12.48. The most astonishing performance of the track had to be Chris Doseck's "return from the back of the pack" to take second with 42, 8:8.88. His Cam/Corally combination was spectacular considering he was over eight seconds ahead of third place Twister/Agitator driver Louis LeBlanc at 41, 8:1.00. Joe Lawrence who had been in it all the way with his Peak Performance/Agitator finished fourth with 41, 8:3.54.

Once again, congratulations to all the winners, and to Ted McCarthy's Rivertown Racers.

Modified
A Main

- 1st - Joel Johnson
- 2nd - Chris Doseck
- 3rd - Louis LeBlanc
- 4th - Joe Lawrence
- 5th - Bill Jeric
- 6th - Carl Christy
- 7th - Mike Seubert
- 8th - Tony Neisinger

- 9th - Chad Coppock
- 10th - Mike Blackstock

B Main

- 1st - Andy Dobson
- 2nd - Bob Light
- 3rd - Wayne Gerber
- 4th - Tyree Phillips
- 5th - Steve Verona
- 6th - Bob Schoenau
- 7th - Dwight Smith
- 8th - Terry Rott
- 9th - Lee Morrison
- 10th - Ron Ferguson

C Main

- 1st - Glenn Tonagi
- 2nd - Glenn Ornat
- 3rd - Paul Martin
- 4th - Frank Calandra
- 5th - Jim Hoffman
- 6th - Mike Ebert
- 7th - Bud Bartos
- 8th - Phil Zimmerman
- 9th - Paul Brower
- 10th - Jeff O'Malley

D Main

- 1st - Mike Marshall
- 2nd - Scott Smith
- 3rd - Randy Meyer
- 4th - Don Jones
- 5th - David Pulfer
- 6th - Mike McBride
- 7th - Mike Pulfer
- 8th - Ken Pepe
- 9th - Dan Louis
- 10th - David Lane

E Main

- 1st - Jason Temme
- 2nd - Tom Lamb
- 3rd - Peter Fitch
- 4th - Eric Whitrock
- 5th - Bernie Piatt

NEW PRODUCTS

TURBO-GLIDE

JRX-2 & JRX-T

BELT DRIVE TRANSMISSIONS

A PROVEN WINNER! IN ITS TESTING STAGES THE TURBO-GLIDE HAS ^{TQ}ed AND WON AT LOCAL, REGIONAL AND EVEN NATIONAL EVENTS. THIS 1/5 PITCH BELT DRIVE TRANSMISSION FEATURES A FULLY ADJUSTABLE BALL DIFFERENTIAL. NOW AVAILABLE FOR THE JRX-2 AND JRX-T, IN ALUMINUM OR GRAPHITE. THESE TRANSMISSIONS ALLOW A LARGER RANGE OF GEAR RATIOS THAN THE STOCK TRANS. THE BELT DRIVE TRANSMISSIONS FOR THE JRX-2 AND JRX-T ALLOW GEAR RATIOS FROM 4.7 TO 1 THROUGH 15.1 TO 1 AND USE STANDARD SPUR GEARS.

**TRACK
MASTER**

TRM4300 ALUMINUM BEARING TRANSMISSION
FOR JRX-2 AND JRX-T.....\$128.95

TRM4301 GRAPHITE BEARING TRANSMISSION
FOR JRX-2 AND JRX-T.....\$148.95

TRACK MASTER, 1466 PIONEER WAY, # 10, EL CAJON, CA 92020 (619) 442-0766

NEW!

Computerized Lap Counting

NOW: Version RCC5.V4 will run your races from sign-up to trophy awards! Using compatible PCs or TRS-80s.

From simple sign-up sheets and quick data entry, the CDS program will make up the entire qualifiers and mains racing schedules, resolve frequency and car number conflicts, print racing schedules and save all data to disc.

Race director has options to select number of cars per race for all classes, and sequence of racing class events.

The actual racing program can run automatically by sequence or be selected by event number from the event schedule. The mains will be automatically made up from quickest qualifying times and laps. All the extensive features of existing RCC5.V3 program have been retained and enhanced to run quicker and easier. Watch for the greatest Total Automatic System Announcement. We at CDS have done it! The fully automatic system, RCC5.V5, will be provided as an integrated system including software, lap counting devices, computing, displaying and printing equipment. A complete across-the-counter line of components will be available for retail sales.

We are tooling up to have RCC5.V5 on the market very soon.

Suggest you purchase the RCC5.V4 system now so that you will be computer-wise when the remaining hardware will be available.

Coordinated Data Service Co.

(619) 788-6851

6th - Kevin Montalbano
7th - Steven Mancinelli
8th - Darryl Binger
9th - Tom Parrot
10th - Dale Smith

F Main

1st - Chris Zimmerman
2nd - Bob Hall
3rd - Douglas Orton
4th - Tony Carruba
5th - Ralph Duncan
6th - Mike Mitzel
7th - Jeff Abler
8th - Andy Holub
9th - Conan Honeck
10th - Mike Ryan

G Main

1st - Bob Novak
2nd - Tom Lamb
3rd - Wei Lin
4th - Mike Stewart
5th - David Arnold
6th - Sandy Stoddard
7th - Shane Patzer
8th - Brian Fogt
9th - Ted Rogers

10th - John Oppenhuizen
H Main
1st - Larry Oppenhuizen
2nd - Bryan Haught
3rd - Anthony Mancinelli
4th - Paul Wagner
5th - John Rogers
6th - Brad Reynolds
7th - Jerry Ryan
8th - Steve Radecky

Stock
A Main

1st - Keith Hamilton
2nd - John Orr
3rd - Joseph Fitzpatrick
4th - Jack Kloeber
5th - John Pens
6th - Chuck Lonergan
7th - Bill Schoenau
8th - Chuck Sommers
9th - Dean Smith
10th - Aaron Treppa

B Main

1st - Steve Boice
2nd - Scott Nelson
3rd - Jim Kerseich
4th - Carrie Gerber
5th - Chuck Mackin
6th - James Arnold
7th - Dave Merano
8th - Willy Decker
9th - Mike Walpole
10th - Stan Naymola

C Main

1st - Brian Wynn
2nd - Rick Rottach
3rd - Ralph Herndon
4th - Bill Worrel
5th - Mike Reniger
6th - Michael Ellis
7th - Bob Morrison
8th - Dave Webb
9th - Craig James Smith
10th - Keith Tessmer

D Main

1st - Scott Williams
2nd - Stephen Charles
3rd - Neal Everhart
4th - Mark Gorney
5th - Mark Calandra
6th - Frank Boling
7th - Randy Midkiff
8th - Dan Dipirro
9th - Bob Joysey
10th - Tom Joysey

E Main

1st - Bill Henn
2nd - Dave Smaltz
3rd - Brian Webb
4th - Richard Panches
5th - John Sohacki
6th - Brett Polivka
7th - Jim Pierson
8th - Tom Alff
9th - Chuck Pfahler
10th - Z.S. Liszkai

F Main

1st - Jeremy Otis
2nd - Scott Linder
3rd - Richar DeZeeuw
4th - Tom Walters
5th - Joe Weeman
6th - Mike Becker
7th - Mark Melone
8th - Ron Shonk
9th - Brent Owen
10th - Jeff Thompson

G Main

1st - Wilkie Wilkinson

2nd - Jason Jacques
3rd - Tom Smith
4th - Derek Smith
5th - Melford Donaldson
6th - Frank Calandra Sr.
7th - Darrell Fuller
8th - Ronald Kwentus
9th - John Thawley
10th - Bill Goupil

H Main

1st - David Lee
2nd - Vince Palazzolo
3rd - Steve Pitcher
4th - John Whyte
5th - Mike Gillette
6th - Chris Pratt
7th - Vicky Carrubba
8th - Nick Cacciola
9th - John Schweitzer
10th - Larry Wodell

I Main

1st - Larry Rice III
2nd - Jim Piper
3rd - Nick Terwilliger
4th - Jeff Brown
5th - Lloyd Leichenratt
6th - Mackie Roberts
7th - Bill Sullivan
8th - Michael Parker
9th - Derek Hurst
10th - Tracy Rumschlag

J Main

1st - Mike Vis
2nd - Tracey Hoffmann
3rd - Darrin Tosh
4th - Jim Tisdale
5th - Bob Kolenda
6th - Bruce Owens
7th - Jeff Faber
8th - Tony Godfrey
9th - Bruce Tremayne III

K Main

1st - Kathaleen Parker
2nd - Kevin Sheren
3rd - Ken Alkema
4th - Greg Kraios
5th - Jake Meyers
6th - Jim McGinness
7th - Russel Raden II
8th - Kevin Gray
9th - Michael Wenzel

L Main

1st - Richard Zbin
2nd - Joey Palazzolo
3rd - Ned Smaltz
4th - Terrie Reniger
5th - Greg McMillen
6th - Ken Hamilton
7th - Tom Vis
8th - Dick Baker
9th - Chris Mockerman

M Main

1st - Henry Miller
2nd - Doug Decker
3rd - Brand Wilkinson
4th - Richard Green
5th - Randy Stanham
6th - Brian Ward
7th - Gene Parker
8th - Justin Harnden
9th - Ken Wheeler

N Main

1st - Steven Ward
2nd - Tara Pitcher
3rd - Jeff Shupe
4th - Larry Dubois
5th - Lorraine Kolenda
6th - George Mockerman
7th - Jim Detrick
8th - Doug Voss
9th - Kelly Vincent



Jim Halsey

Jay Halsey

Cliff Lett

Mike Reedy

Butch Kloeber

The Hot Tip from Hot Racers

When a solder joint can make the difference between TQ and DNF, you find America's top racers using only the best soldering equipment: Ungar's Super Race Station. Its incredible power not only makes soldering easier and faster, but makes joints flow better for greater reliability and lower resistance. And the quick transfer of heat will protect your sensitive race-ready batteries.

Secrets revealed

The key to the *Super Race Station's* incredible performance lies in its sophisticated electronics. Unlike conventional irons that have a fixed output rated in watts, the Ungar unit has an automatic variable output that keeps the iron tip at any temperature you select, all the way from a mild 400 degrees for precision work to a blistering 800 degrees.



The handy stand keeps the iron safely out of the way of car components in your pit area. Sponge helps keep a clean tip for the extra strong solder joints.

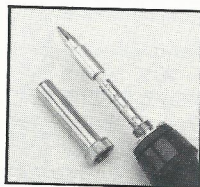

Unlike any other solder station, the *Race Station* comes equipped with a high mass thermal thrust tip that's perfect for R/C use.

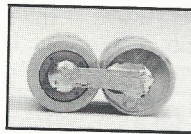

Incredible output allows solder to flow all the way across this battery braid in seconds.

In fact, the *Race Station* has so much power that most racers adjust their temperature controls to about the 750 degree point.

You can buy the same unit

The pros you see use a stock *Race Station*, just like the one you can buy at your local hobby store or race track. Retailing at just \$119.95 for the *Super Race Station*, or \$109.95 for the smaller handled *Race Station*, they're an investment that will pay off handsomely... in better solder joints, and more TQ runs.

UNGAR®

The Hottest Tip in Racing

Exclusively distributed to your local shop through Horizon Hobby Distributors, Inc.

NORRCA

NATIONAL ORGANIZATION FOR RACING RADIO CONTROL AUTOS

1990 DIRT OVAL NATIONALS

AUGUST 17TH - 19TH CHATHAM, VIRGINIA

HOSTED BY COOPER'S R/C CENTER

NORRCA MEMBERSHIP IS REQUIRED * (MEMBERSHIP IS AVAILABLE AT TRACK OR THROUGH NORRCA) * NORRCA RULES APPLY
NORRCA OFFICIALS WILL BE PRESENT * SHIRTS FOR PRE-ENTRANTS ONLY * NORRCA T.Q. PINS & TROPHIES FOR TOP QUALIFIER IN EACH
CLASS * TROPHIES 1st -10th IN ALL "A" MAINS 1-3 ALL MAINS * CONCOURS TROPHIES 1st - 3rd * TROPHY DASH FOR EACH CLASS * HOST
HOTEL IS THE "INN KEEPERS MOTOR LODGE (DANVILLE NORTH) 804-797-4954 & 804-799-1202 (DANVILLE WEST) *YOU MUST ASK FOR THE
NORRCA RACE RATE SPECIAL* * GREENSBORO AIRPORT * OVER-NITE PARKING O.K. * **BRING YOUR FOAM TIRES**, SPIKES WON'T WORK
ON THIS TRACK * 3RD ANNUAL NORRCA TEAM CUP CHALLENGE - THE TEAM WITH THE HIGHEST OVERALL POINTS WILL BE AWARDED
A GOLD CUP FOR "THE BEST DIRT OVAL TEAM" OF 1990 * ENTRIES LIMITED TO 400 * PRE-ENTRIES CLOSE AUG. 11TH * ENTRIES DAY OF
RACE IF AVAILABLE \$50.00 * STOCK MOTORS WILL BE SUPPLIED.

SCHEDULE: AUG. 16TH PRACTICE & CHECK-IN ALL CLASSES 9AM-9PM * 17TH 6:00 AM - 8:00 AM CHECK-IN, 8:30AM 1ST HEAT, 2:00PM
2ND QUALIFIER * 18TH 7:30AM CONCOURS, 8AM 3RD QUALIFIER, 2:00PM 4TH QUALIFIER * 19TH 8:00AM -9:00AM TROPHY DASH, 9:30AM
START OF LOWER MAINS. * SCHEDULE MAY VARY AND CAN BE ADJUSTED AT ANYTIME.

***** SPONSORED BY *****



SHIRTS DESIGNED & PRINTED BY D.J. RENWICK

NATIONAL CHAMPION RACE CASES WILL PROVIDED BY ADVANCED RACE CASE

NORRCA OFFICIAL 1990 DIRT OVAL NATIONALS ENTRY FORM

NAME _____ PHONE _____

ADDRESS _____

CLASS(ES): 2W STOCK ___ 2W OPEN ___ 4W STOCK ___ 4W OPEN ___ OUTLAW SPRINT ___

2W FREQUENCIES 1. ___ 2. ___ 3. ___ SPONSOR(S) _____

4W FREQUENCIES 1. ___ 2. ___ 3. ___ CAR _____ MOTOR _____ RADIO _____

ENTRY FEE: \$35.00 1ST CLASS., \$25 EA ADD'L CLASS. STOCK CLASS \$40.00 (INCLUDES 1.
MOTOR) NO ENTRY REFUNDS. SEND ENTRY & CHECK PAYABLE TO:
NORRCA, 1530 W. 8TH ST #117, UPLAND, CA 91786. FOR ADD'L INFO. CALL COOPER'S AT
804-724-4182 OR NORRCA AT 714-981-9641

NORRCA # _____

(Continued from Page 25)

4 Wheel Stock

A Main

- 1st - George Johnson
- 2nd - Tony Maganuco
- 3rd - Jim Walker
- 4th - John Keck
- 5th - Justin Albright

4 Wheel Open Truck

A Main

- 1st - Robert Wedner
- 2nd - Paul Montgomery
- 3rd - Tom Cox
- 4th - Tom Cat
- 5th - J.G. Sr.
- 6th - Richard Ambrosia
- 7th - Ed Askew
- 8th - J.B. Hunt
- 9th - John Hammer Smith
- 10th - Clifford Stroemer

B Main

- 1st - Richard Ambrosia
- 2nd - Justin Albright

Super Stock Truck

A Main

- 1st - Robert Melton
- 2nd - J.B. Hunt
- 3rd - Bill Ogden
- 4th - Mike Kendall
- 5th - Dan Vels
- 6th - Tom Owens
- 7th - John Keck
- 8th - David Wilson
- 9th - Robert Malone
- 10th - Steve Moore

B Main

- 1st - R. Adams
- 2nd - Racin Bob Kaufman
- 3rd - Phred Gebauer
- 4th - Ryan Clark
- 5th - Ed Correa
- 6th - John Reichling
- 7th - Ron Vanert
- 8th - Ken Shintani
- 9th - Mike Fox
- 10th - Jeremy Kortz

C Main

- 1st - Dave Knox
- 2nd - Darrel Hubert
- 3rd - Brandon Baker
- 4th - Tim Moto
- 5th - Randy Burns
- 6th - Anthony Munoz
- 7th - Tom Pendergast
- 8th - Tom Cox
- 9th - Mike Dunlap
- 10th - Phil Ramsey

D Main

- 1st - Will Balisky
- 2nd - Keith Heaton
- 3rd - Tom Cat
- 4th - Hai Vo
- 5th - Randy Shewey
- 6th - Brian Stine
- 7th - Tommy Weed
- 8th - Cindy Schultz
- 9th - Ryan S.
- 10th - Cliff Montgomery

E Main

- 1st - David Bush
- 2nd - Gene Ogle
- 3rd - Frank Bruer
- 4th - John Hansen
- 5th - Arnold Thomas
- 6th - Bob Hale
- 7th - Debbie Burrie
- 8th - Wally Jimenez
- 9th - Lane Sporrang
- 10th - Darin Santiago

DAHM'S

DAHM'S RACING BODIES

P.O. BOX 360, COTATI, CA 94931 (707) 792-1316
21 NEW PRODUCTS! SEND \$2.00 FOR NEW CATALOG AND DECALS

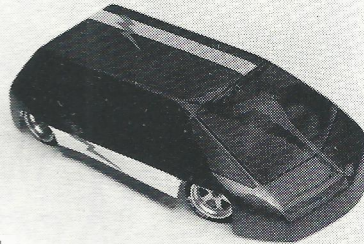

1.

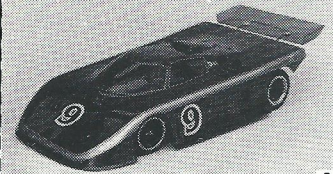

2.

- 1. AVENGER 2000™
- 2. FIREBIRD GTP
- 3. WARRIOR II™
- 4. STARFIGHTER™ (AEROSTAR)
- 5. THRILLER™ (NISSAN)
- 6. TUFF-E NUFF™ (FORD RANGER)

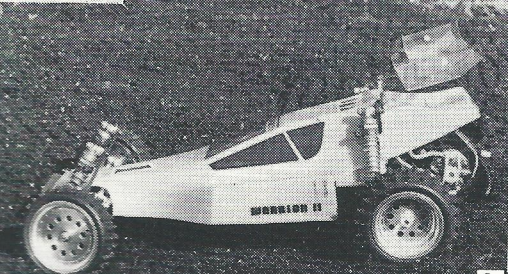

3.



4.



5.



6.

DAHM'S FOUR NEW RACING TRUCK BODIES FIT MOST 10TH SCALE CARS FROM THE RC10L TO THE CLODBUSTER! TAKE YOUR CHOICE: MONSTER TRUCKS, MUD BOGGERS, PULLERS, VANS, DRAG TRUCKS, PANEL TRUCKS, LOW RIDING STREET TRUCKS PLUS A VAN FROM THE FUTURE!

DAHM'S LONG, LOW, LEAN AND MEAN WARRIOR II™ IS THE NEWEST RACING BODY FOR THE RC10 AND FITS MOST OTHER 2WD CARS. WARRIOR II POWER PAN™ IMPROVES AERODYNAMICS AND KEEPS THE DIRT OUT! DAHM'S MONSTER POWER PAN™ (LEXAN UNDERBODY) FITS MOST MONSTER CONVERSIONS, AND INCLUDES A SUPERCHARGER! DAHM'S NEW FIREBIRD GTP INCLUDES A FREE WING, AND WILL MAKE YOUR 12TH SCALE CARS LOOK AND HANDLE GREAT. DAHM'S NEW ADJUSTIBLE, BI-LEVEL, LEXAN FX™ WINGS ARE A MUST FOR ALL 8TH, 10TH, AND 12TH SCALE R/C RACING CARS. GET YOURS TODAY!

ASK FOR DAHM'S NEW PRODUCTS AT YOUR LOCAL HOBBY SHOP OR RACE TRACK. OR CALL 707-792-1316. EXPERIENCE THE EXCITEMENT!™

From the **TWISTER** laboratory of the mad...

DR. MIKENSTEIN and...

his faithful assistant...

ERIK VON-QUICK

We've done it Erik!...
The most awesome motors
ever to be created!!!



"Professor von Quick" and "Dr. Mikenstein"
can give you the "POWER" too!!! Put a "TWISTER
MOTOR" in your car and start winning today!

TWISTER MOTORS 657 E. ARROW HWY. #H GLENDORA, CA, 91740
call the "Hotline 818-914-6177" for a free tuning guide

F Main

- 1st - Dennis Lytton
- 2nd - Mike Grijalva Sr.
- 3rd - Larry Rizer
- 4th - Mark Almonrode
- 5th - Steven Chambers
- 6th - Jim Stevenson
- 7th - John Wong
- 8th - Jim Varner
- 9th - Clifford Stromer
- 10th - Duane Warnke

G Main

- 1st - David Potter
- 2nd - Tom Hodgkin
- 3rd - Michael Grijalva
- 4th - David Garvin
- 5th - John Hammer Smith
- 6th - Mark Newberry
- 7th - Richard Dunlap

4 Wheel Open**A Main**

- 1st - James Ward
- 2nd - Joe Horvath
- 3rd - Dave Highfill
- 4th - George Johnson
- 5th - Chad Christians
- 6th - Jerry Gumaer
- 7th - Craig Lair
- 8th - David Messimer
- 9th - Richard Ambrosia
- 10th - Justin Albright

Novice**A Main**

- 1st - Steve Taffert
- 2nd - Shale Witting Ham
- 3rd - Mike Ryer
- 4th - Dennis Rizer
- 5th - Gary Westbury
- 6th - Michael Ries
- 7th - Scott Petrus
- 8th - Aldo Ruiz
- 9th - Kevin Bowman
- 10th - Jason Robinson

B Main

- 1st - Todd Siler
- 2nd - Eric Hase
- 3rd - Earl Siler
- 4th - James Wyatt Atkins
- 5th - William Walker
- 6th - Andy Amento
- 7th - John Rodriguez

2 Wheel Stock**A Main**

- 1st - John Schultz
- 2nd - Eric Beier
- 3rd - Steve Gilmore
- 4th - Rick Wood
- 5th - Gene Mason
- 6th - David Gestoso
- 7th - James Ward
- 8th - Curtis Stock
- 9th - Roger Tibbets
- 10th - Jessie Watson

B Main

- 1st - David Potter
- 2nd - Marcus Osborne
- 3rd - Andy Bartucca
- 4th - David Messimer
- 5th - Billy Spence
- 6th - Mike Lockman
- 7th - David Goss
- 8th - Bill Gerring
- 9th - Tony Maganuco
- 10th - Edwin Barr

C Main

- 1st - Jamie Meyers
- 2nd - Larry Lockman
- 3rd - Joe Fiocca
- 4th - Roland Chavarry

"HOT LAP"**DISTRIBUTOR**

3080 West 96th Avenue • Westminster, CO 80030

303/428-6132

**1/8 SCALE
GAS CARS**

- Cobra III Parts
- Hot Laps Racing Fuel
- New Sonic Filters
- New High Temp Exhaust Tubing
- Delta Parts
- Tires
- Pinzini Motors

**ELECTRIC 1/10-1/12
SCALE CARS**

- Delta Parts
- Hot Laps Tire Traction "Grip"
- Super Slick Oil
- Peak Performance Motors
- Tires

SEND \$4.00 FOR CATALOG

- 5th - Arnold Thomas
- 6th - Shawn Rogers
- 7th - Jimmie Williams
- 8th - Dwight Rader
- 9th - Mike Veiez
- 10th - Larry Rizer

D Main

- 1st - Jim Walker
- 2nd - Gil Aguilar
- 3rd - Marcus Smith
- 4th - Tom Cat
- 5th - Phil Ramsey
- 6th - Lane Sporrang
- 7th - Clifford Stroemer
- 8th - Mike Dickeson
- 9th - David Cleveland
- 10th - Mark Newberry

E Main

- 1st - Jeremy Hase
- 2nd - Tony Gammel
- 3rd - Wayne Milho
- 4th - Ed Okada
- 5th - Sandy Hunt
- 6th - Tom Hodgkin
- 7th - Craig Kubota
- 8th - Tien Vo
- 9th - David Mount
- 10th - Chris Verano

F Main

- 1st - Demonic LeConte

THE BIG ONE*By Paul Weber*

The place: Thornton Memorial Park, Bedford, Indiana (midway between Indianapolis, IN and Louisville, KY). The event: The First Annual Southern Indiana Model Racing Association (SIMRA) 1/10 scale 24 Hour On-Road Challenge.

In the pit areas, teams worked furiously to prepare their cars for what would be the longest race ever attempted by our young club. Previous weekly racing has been held on smaller courses, both on-road and off-road, ovals and patterned layouts, and these lasted only three or four minutes. This race would be on a 600' flat

asphalt road course which was set up the day before, thus, driving this layout would be a new experience for all involved. The race was against the clock, with the winning team completing the most laps in the allotted time. Since the race was a 24 hour, 1/10th scale endurance event, the actual time would be 2.4 hours (2 hours, 24 minutes)!!! The first thing everyone wondered about was battery performance and motor/speed control endurance. None of the club racers had ever tried racing a car for this length of time before. This would surely be a learning experience for all involved.

Teams were formed, each of which consisted of two main drivers, a back-up driver and two pit crew members. The rules required that each of the main drivers had to control the car for at least 15 minutes of each one hour period, so that both drivers would be given a chance to race. At any given point during the race, at least one crew member would be required to perform as a turn marshal, with other crew members handling pit responsibilities.

Technical restrictions for the cars were set at a monthly SIMRA Club meeting, a few months before the race. The cars would have to be on-road chassis, with GTP bodies and limited to a maximum of seven cell batteries with standard connections (no enduro packs allowed). The motor choice was left open, as was the gearing and

Power Clutch

A&L's new Power Clutch takes you beyond the ordinary "slipper".

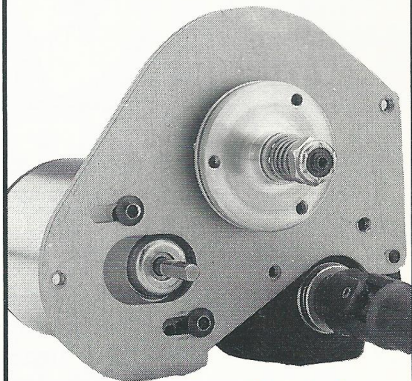

The new Power Clutch from A&L will improve handling and lap times by eliminating fish-tailing and spin-outs off the line and in the corners!

- Eliminates destructive torque, saving tranny idlers and gears, dog bones and spur gears
- Change spur gears without disassembling Power Clutch, preserving Clutch adjustment
- Design incorporates large (1" OD) high temperature disk providing extremely consistent performance, race after race
- Prevents excessive tire wear due to poor traction
- Fits JRX-2/T, MIP and A&L transmissions

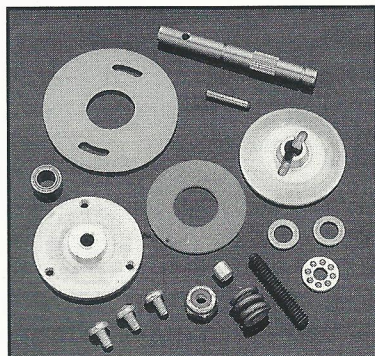

See Your Local Hobby Dealer Or Contact:



A&L MANUFACTURING • P.O. Box 2115
Corona, CA 91718 • (714) 735-5249
FAX (714) 735-5642 • Catalog \$2.00

©1990 A&L MANUFACTURING

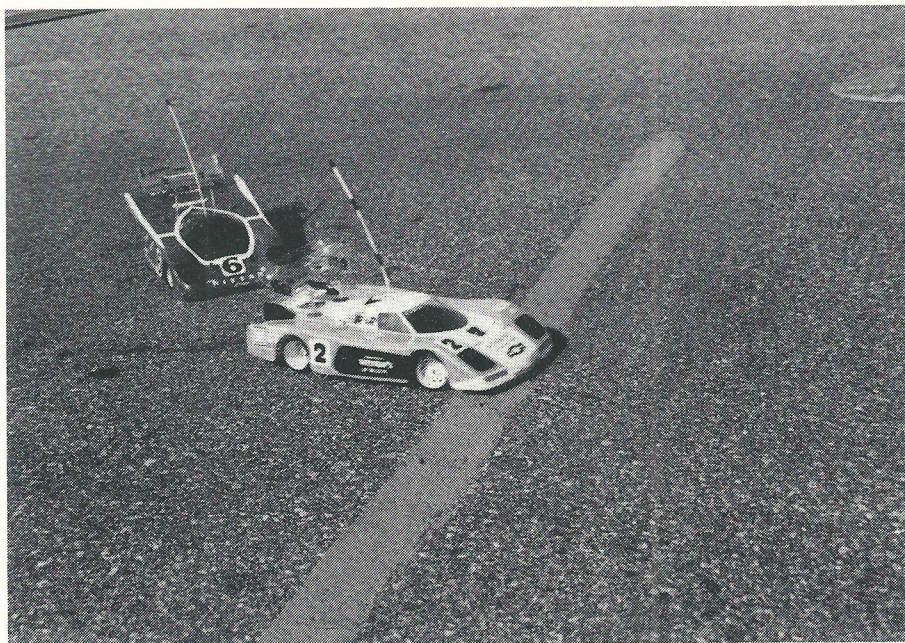

Nip & Tuck - All The Way!

transmission selection (most teams used 24-25 wind motors with bearings). Major concerns with the majority of the teams was how many batteries would be required to run the race, how long would the motor/speed controls would last, and how many tire changes would be necessary. The teams scrambled to find sponsors, and equipment (tires, batteries, spare parts, etc.) before the big event!

Since this was the first race of this magnitude we had ever attempted, we were all somewhat apprehensive about the attendance, performance of the club & volunteers and (of course) our cars. As it turned out, six teams were entered, most from our club membership, with some teams recruiting outside help. We had a computer scoring system (not an auto count system) which required calling out and entering each car number via keyboard as they crossed the start-finish line. (Since this race we have upgraded our computer system to a counting system utilizing "pickles" (push button switches) for counting laps, with our goal being the auto count system we've all seen advertised. We just couldn't afford that system yet!). We were prepared to have as many as ten cars entered, however, it was just as well that there were only six

due to the complexity of scoring the race with our current scoring system and this duration.

Qualifying for starting position was held the morning of the race. One of the requirements was that however the car was set up for qualifications (tires, motor and gearing) it must start the race the same way. Changes in motors, tires and gearing would be allowed during any of the pit stops which would be performed during the race. Since enduro battery packs were not allowed, it was also ruled that a team would be required to completely remove the body and install the battery, in order to put the teams on equal ground, with the same time requirement for basic stops, and more true to realistic pit stops.

With qualifying completed, the cars were lined up (LeMans style) and we were ready to begin. The announcer counted down to the start of the race, six drivers were standing, ready to take the track . . . and . . . we're off!!! The cars were speeding into the turns, sliding around the curves and blasting down through the straight-aways. Good braking techniques were essential to maneuvering the course layout with the speed required to keep pace with the lead car. Average lap speeds were running in the
(Continued on Page 79)

POWER TRAIN: RC10 TRANSMISSIONS

By Jeff Palmer

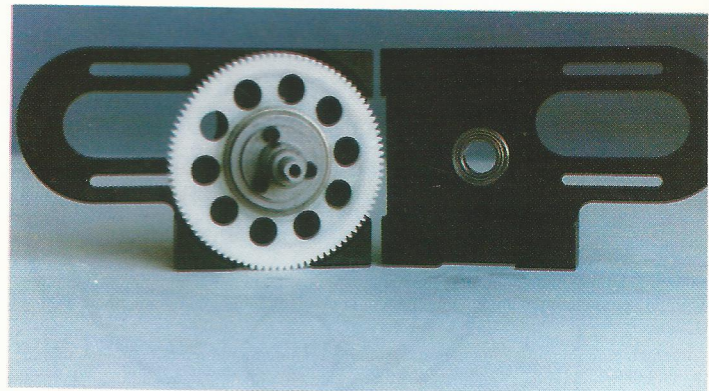
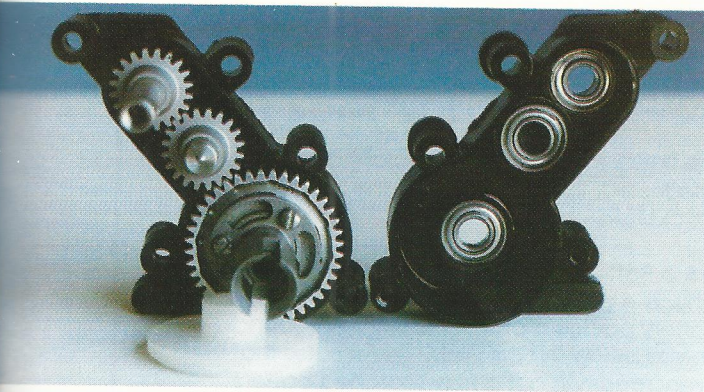
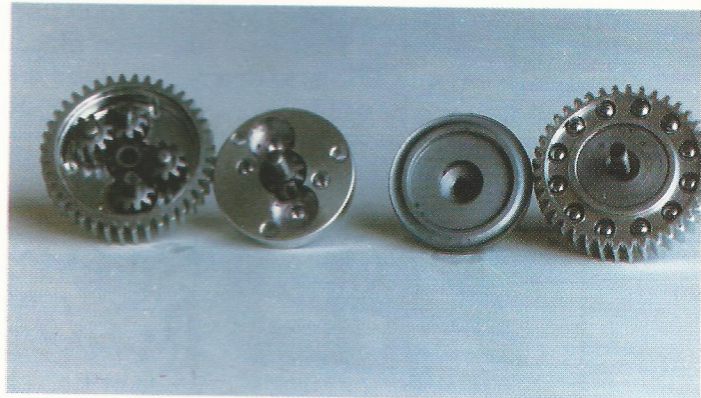
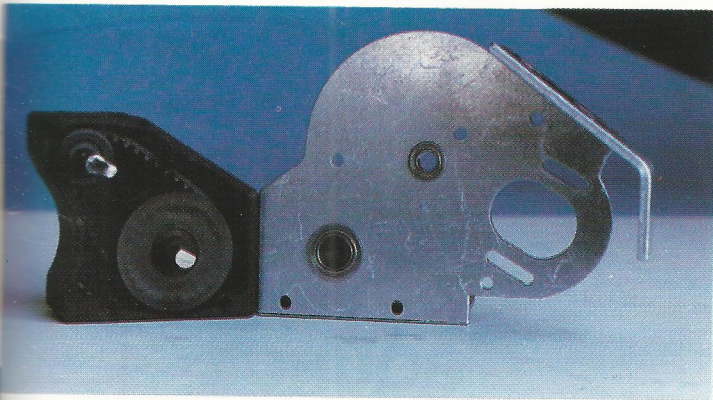
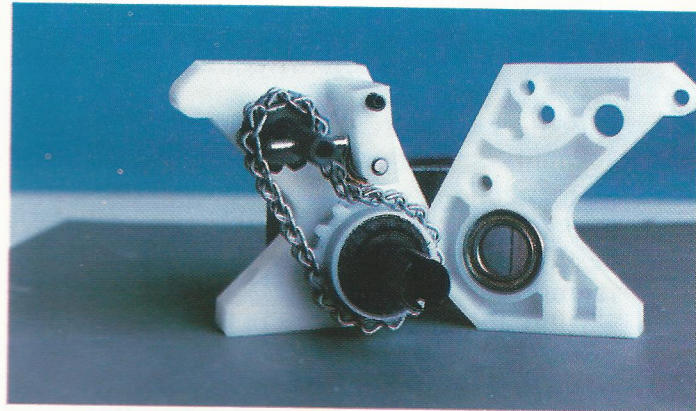
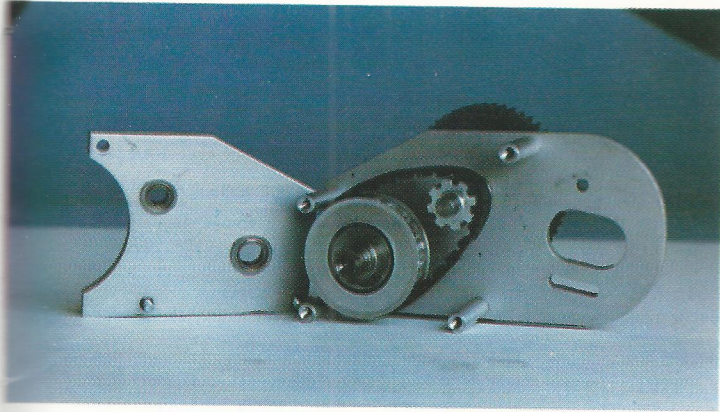

Above: Left: Track Master's Belt Drive. Shown with aluminum motor mounts. Also comes with graphite motor mounts. Right: Team Pit Stop Chain Tranny. A solid performer and all around good transmissions. Middle: Left: Bullet Racing's Gear Diff/Belt Tranny. Needs a lot of work to make it perform well - but when it does . . . Right: Compare MIP's gear diff with MIP's ball diff. Both are great. Below: Left: MIP's Gear Diff Tranny - SPI-Plus - a new standard in the making. Use it on any track. Right: JCAR - DDS Diff. Great on Oval.

The Associated RC10 is a staple in today's 2WD class. It has more options, performance parts, and conversion kits than all other kits combined. The transmission has been, and still is, one of the focal points for changes. MIP, Team Pit Stop, Track Master, Bullet Racing, and JCAR all make replacement trannies for the RC10 and yet each takes a different approach. One uses a gear drive, another uses a chain drive, a third uses belt drive and yet another can use either gears or belts. With all these options available, which one is better on high traction or low traction tracks? Which transmission works best for oval, off-road or on-road racing?

All of the transmissions in this article are good choices but each has a special area where it works best. A gear transmission works better for an off-road race than does a belt transmission. A direct drive transmission/diff works best for on-road. The key to transmission selection is to determine how it's to be used.

MIP SP-1/SP-1HD Trannies

The MIP SP-1 transmission has been around for about 4-5 years in various forms and has proven itself to be a great performer. It has a very simple drive train consisting of three gears and a completely sealed case to keep dirt out. It is the smoothest of the transmissions tested and it has the reputation for being **THE TRANSMISSION** for low traction tracks! The gears are machined brass or steel (heavy duty) and require no deburring. In fact, these transmissions are so well engineered, that assembly will be a pleasure. Each of the gear's shafts are mounted in precision ball bearings. The only difficult part about the assembly is keeping track of the 3/32" balls. The secret to handling these balls is to use the purple grease provided with the kit. Place a little grease on the innermost race where the balls are to be placed and then place a little of the grease on the tip of a screw driver. Touch the tip of the screw

driver to one or two of the balls and transfer them to the race. Simple and effective.

The MIP SP-1 and SP-1HD transmission will not lock down like the Associated RC10 transmission. Under hard acceleration, these transmissions will slip for about 6-10 feet, allowing for a very even take-off. This type of action is a must on low traction tracks, however, this smooth action will not get you the "hole shot" many racers like to get coming off the line. MIP trannies tend to make a little noise. To help reduce the noise, MIP makes a delrin idler gear for the SP-1 tranny. The delrin gear should only be used with stock motors, it has a tendency to melt under the high RPM of modified motors or strip under the high torque demands of monster trucks. The SP-1HD tranny is specifically designed to handle the heavy duty demands of monster trucks and super modifieds.

Both the SP-1 and SP-1HD are staples in my pit box. I use them for all low traction or tight cor-

A & D Racing Products

SANYO
BATTERIES

THE
POWER
SOURCE

NATIONAL CHAMPIONS
BREAKING TRACK RECORDS

1989 Roar 1/10 Dirt Oval
NATIONALS 1ST PLACE
Sammy Blackwell
used **A & D** Batteries
and won **BIG**.

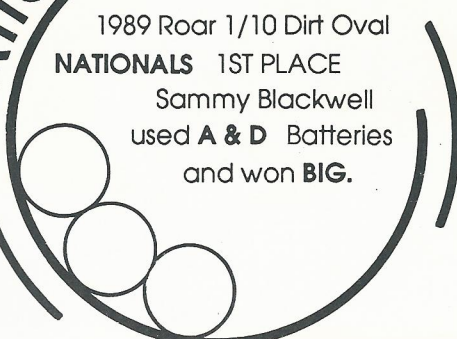

A & D Racing Products has won **NATIONAL**, regional, and state championships throughout the U.S. and has qualified several racers to compete in upcoming IFMAR WORLD CHAMPIONSHIPS.

A & D Racing cells are especially conditioned and tested, then matched to the 3rd cycle on a specialized computer system.

A & D Batteries are not only matched on run time, but other characteristics as well, and every battery pack is matched to within 3 seconds before being shipped out. This ensures that every racer will get a truly matched battery pack.

A & D Pricing is very competitive and in most cases considerable lower than our competitors prices.

For more information: **A & D Racing Products**
#12 Plaza 94 Suite 218
Ph: 314-441-0773 St. Charles, Mo. 63303

Speedworks®

1990 Sportsman Triad™ Cup Series

Race 1, 1/10th on-road banked oval

MEGATRAK SUPER SPEEDWAY

262 sportsman entries!

Sportsman winner: Jonathan Moore

1/12th winner: Scott Frazier

Invitational winner: Joel "Magic" Johnson® 30 laps.

Joel broke the modified 7 cell track record running 6 cells and a stock motor!



Race 2, 1/10th off-road

SEMROCC

(Nationals Track)

July 6, 7 & 8

Sterling Heights, Mi

(313) 644-0669

Race 3, 1/10th on-road road race

RANCH PIT SHOP

October 5, 6 & 7

See 10 of the Worlds best drivers compete in a special invitational race!

Joel Johnson

Tony Neisinger

Bob Light

(Trinity)

Gil Losi Jr.

(Team Losi)

Bud Bartos

(Bud's Products)

Rick Hohwarth

(Peak Performance)

Andy Dobson

(Compositcraft)

Etc., etc., etc!

Non sponsored drivers only, Speedworks hand out stock motors, seminars by 10 of the top drivers in the World. Come to learn, race and be the "Speedworks Sportsman Triad Cup National Champion!" The overall champion will be crowned at the Ranch!

For more information please use the numbers listed for each event. All entries will be handled by the individual race. Trinity Products Inc. reserves the right to refuse any entry.



2 TIME IFMAR WORLD CHAMPIONS

1901 E. Linden Ave#8 • Linden, NJ 07036 • Ph (201) 862-1705 • Fx (201) 862-6875

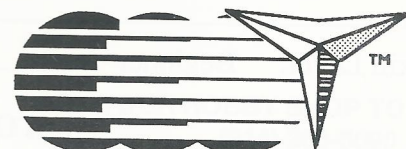

Rivertown Racers

present



Region III



Monster Truck Off Road Championships

(No buggies allowed !!!)

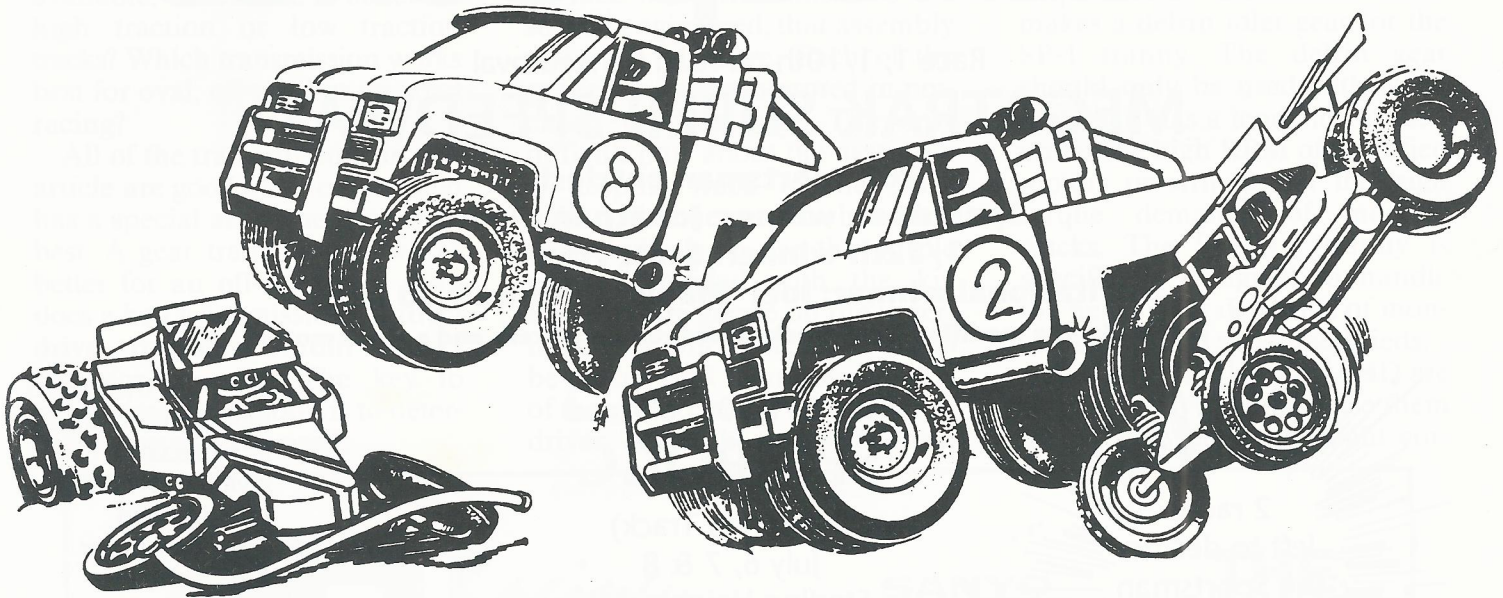

August 3, 4 & 5

Rivertown Race Park • Grand Rapids, Michigan
2 Door Race Pick-up Bodies Only

Race Packet & Current Rules will be returned upon receipt of entry

For Additional Information: Call Ted McCarthy (616) 458-2281 or (616) 363-8256

Send a Large Self-Addressed Stamped Envelope with Your Check to:

Rivertown Racers

1690 Waterburg Drive – Grand Rapids, MI 49508

4 W Stock \$30.00 _____ 2 W Stock \$30.00 _____ 4 W Modified \$25.00 _____ 2 W Modified \$25.00 _____

Frequency 1. _____ 2. _____ 3. _____

Name _____ ROAR No. _____

Address _____ Phone # _____

City _____ State _____ Zip _____

Skill Level: Beginner _____ Intermediate _____ Expert _____

TOTAL AMOUNT ENCLOSED _____

Registration Closes July 31, 1990 – Limit 150 Entries Per Class – Trophies – All A Mains, -3 All Others

nering tracks where an even take-off is a must. These transmissions are simple to assemble and require minimal maintenance, but they do require lubricating: follow the recommended lubrication instructions closely. The MIP instructions are simple and easy to follow.

HOLD THE PRESSES!! Eustace Moore of MIP has just introduced its SP-1 PLUS transmission. This tranny has a gear diff instead of a normal ball diff, but it is **SMOOTH!!** Adjusting this transmission is simpler than SP-1. It has a torque adjustment nut on the back side of the spur gear shaft and with a quick twist of the nut driver an adjustment can be made. The early tests indicate that this transmission is well on its way to becoming the transmission of choice for low traction or tight tracks. With the new "Tork Control Unit", the SP-1 PLUS can be locked down to provide you with the "hole shot" of the Associated transmission on high traction tracks. Imagine, a transmission with a smoother action that the SP-1 and the ability to be "locked down"!

Team Pit Stop Tranny

About two years ago, Team Pit

Stop(TPS) introduced its chain drive transmission. I immediately compared it to the chain drive on 4WD cars, that is, in the early stages of break in, the chain stretches and will require a link to be removed. The TPS tranny did not let me down, once the tranny was broken in (about 6 runs), it needed to have a link removed. To do this you'll need to open up two consecutive links, remove the first and carefully reconnect the chain. A minor word of caution: Don't get carried away opening and closing the link - Open the link just enough to slip the other link out and close the link without crimping the wire. Over tightening (crimping) the link or binding the link will bind the chain and cause a loss of power. The TPS instructions outline this procedure very closely, **FOLLOW THEM TO THE LETTER.** In the second step, during the upper shaft assembly, take the time to assemble the upper shaft and line up the upper shaft sprocket with the diff sprocket. Loosen the two set screws on the upper shaft sprocket and twist it slightly, allowing the set screws to score (mark) the upper shaft. Disassemble the upper shaft assembly and use a file or a moto tool to flatten

parallel sides of the shaft on the score marks and re-assemble the upper shaft. This time line up the set screws with the flattened spots and tighten the set screws. This procedure will help eliminate slipping of the upper sprocket. The TPS tranny is an open unit, that is, it's not a sealed transmission like the MIP or Associated trannies. It comes with one of the most thorough set of instructions of any of the transmission kits. The kit contains two upper and two lower gears, allowing the transmission to be setup with 4 different ratios. It can be geared from as high as 1.87:1 or as low as 2.28:1, making it one of the most versatile transmissions available.

The TPS tranny has a very smooth action like the MIP SP-1. It requires a little more maintenance, since it's an open diff, but there's very little to go wrong. The TPS tranny is easy to take apart and clean and easy to change the upper and/or lower gears. I use this transmission when I want more low end than I can get from my MIP. I also have begun using it in place of my Associated tranny. This unit is a winner!! It works well with monster trucks.

ERI
assoc., inc.

THE Electric R/C Car Specialist

(914) 268-5090

FAX

(914) 268-0462

OVER 130 Companies Stocked

DEALERS ONLY!!

Advanced X2 A&L
Airtronics Aerotrend
Andy's Aristo-Craft
Ascot Associated
Astro Flight Autographics
Big Boy Toys Blk Magic
Bold Creations Bolink
B&R BRP
Bondhus
Bruline Bud's
Cheetah Cam Checkpt.
C&M CMW Cobra CRP
Composite Craft Cobra
Competition Electronics
CSC Dan's Dahm's Delta
Dubro Dialed Racing
Fine Design
Five Star
EdgeGonzo
Great Grease Houge
Hot Trick Hyperdrive
Jammin' (JH) Products
Imex JG Kimbrough
J-Car KO Propo KRP
KSC Lazerlite Lightspeed

Litespeed Losi MCS MIP
Max Industries MPE
Monolithic Pow'r Supply
McAllister Minitech MRC
Miracle Speedway MRP
Norcal Novak Pactra
Paragon Parma Pitstop
Peak Performance
Power Pak Pro Line
Pro Cut Protech Ram
Progressive Technology
Protrack RaceMaster
RaceCo
Race Prep
Racer's Choice
Racing Silks
RC Perf. Spec.
RacingScaleSport
Revtech RPM
Rochester Raceway
Rockbusters Scat
Robinson Racing
Sassy Chassis SRS
Sermos Speedworks
Shinwa Stage III T&A

Stormer S.T. (Skis)
T.A. Emerald Industries
Team Hammer Tekin
TeamSmoothTecnacraft
Thorp TM TMS Traxxas
Track Master TrinityTRC
Twinn-K Twister Ungar
You-G Universal Energy
Victor VRP WSS, Inc.
Zeta

NEW COMPANIES

Branson
(Ultrasonic Cleaners)
Bullet Racing ESP
Fast Racing Marui
Premier Designs
Redline Royal
Smokin'

If you do not see it here...just ask!

WHAT'S NEW?

1. Thorp BF telescoping axle kit,
2. Ultrasonic cleaners,
3. Twister-- Pocket Rockets,
4. Fluorescent Race Cases,
5. Batmobile Body,
6. Thorp 48 pitch RC10 gear box,
7. JG Stadium Race Truck,
8. FRP brush alignment tool,
9. Marui Big Bears,
10. MCS brush cutting tool,
11. MIP Slippers.

ASK YOUR HOBBY SHOP TO CALL.... (914) 268-5090

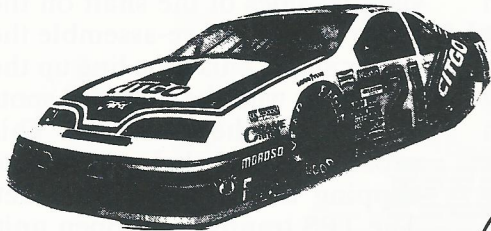

R/C SUPERDROME®

San Diego, CA.

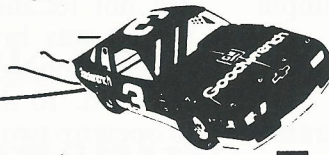

COMPETITION

PLUS THE R/C CAR MAGAZINE

PRESENTS THE

1st Annual

WESTERN

HIGH BANKED

Oval Speedway

Cajon R/C Speedway

July 2,3,4 Fourth of July!

30° Banks, 1075 Feet Long, Biggest in the west

Speeds over 70 MPH!!!

- 1/10 Scale Stock Car Bodies
- Sportsmen and Invitational Classes*
- Expert Class Super Speedway Enduro and Insane Speed Run!
- Tune Up For **THE THUNDERDROME!**



SPONSORED BY

- Hobby Town • Novak • E&L • Tekin • Hobby Shack •
- Sir Speedy Printers-Kearny Mesa- The Racer's Printer • OBR • Andy's •

ENTRY FORM

SPORTSMEN

- Direct Drive Stock (Nascar/Asa Bodies) 6 Cell, Handout Motors, 4 minutes
- Direct Drive Modified (Winston Cup Bodies) 7 Cell, Modified Motor, 4 Minutes
- Gearcase Modified (Nascar/Asa Bodies) 7 Cell, Modified Motor, 4 Minutes
- 1/12 Scale Modified (Nascar Bodies) Modified Motors, 5 Minutes

EXPERT

- Direct Drive Modified 7 Cell, Modified Motor, 4 Minutes
- Superspeedway Enduro 7 Cell, Modified Motors
- Insane Run (Electric) Anything You Can Fit Under A 1/10th Nascar Body.

Name: _____

Address: _____

Phone No.: _____

Sportsmen Class Expert Class

Frequency 1. _____ 2. _____ 3. _____

GENERAL INFORMATION

Dates: July 2, 3, 4
Sportsmen Class: Entry Fee \$ 40.00 Modified Classes
 \$40 Stock Class With Handout Motor

Sportsmen Entries Limited To 200

Expert Class: Any R/C Industry MFG. Interested In Participating In The Expert Class With Racers Or Sponsorship, Please Contact San Diego R/C Superdrome
(619) 278-1491

Entry Fee \$40.00 All Expert Classes
 \$20.00 any 2nd Class

Make Check Payable To: San Diego R/C Superdrome

Mail Check & Entry To: San Diego R/C Superdrome
 2551 Comstock St.
 San Diego, CA 92111

Note: All Entrants Must Be A ROAR Member.

Track Master Tranny

The Track Master tranny was the first belt drive transmission on the market. It's really quiet! It can be bought with 2.01:1 or 2.25:1 ratios. One of the first things you'll notice about the tranny is how it's mounted. The MIP and TPS trannies are mounted using the same mounting holes as the Associated transmission. The Track Master transmission uses the same mounting holes used by the rear "A" arm mounts. The "A" arm mounts can be assembled on top of the tranny's mounting bracket or you'll need to convert your car to rear trailing arms. If you mount the "A" arm mounts on top of the transmission brackets, the rear will be lowered about 1/16". This may effect the handling of the car.

This transmission is very solid and has worked well on dirt oval and on road tracks but it has not done well in the rigors of off-road racing. It has many of the low traction characteristics of the MIP tranny.

Bullet Racing Tranny

This is the newest belt tranny on the market. It has all of the advantages of a sealed transmission with a unique twist - IT HAS A GEAR DIFF!! Like the MIP SP-1 Plus, this gear DIFF is very smooth but requires some work. Each of the gears in this diff are cast metal and need to be deburred. Use a small needle file and go over each gear carefully. Overall the transmission is smooth and works well for dirt oval and on-road racing. The early tests for off-road indicate it will do well here but I'm still testing it because in the past belts have not fared well in the dirt.

The Bullet tranny uses an external slipper clutch to distribute power. The slipper clutch will allow this transmission to be set for various amounts of slip to the point where it's "locked down", a good power range. One of the interesting features of this

transmission is the pinning of the upper shaft sprocket, eliminating the flattening procedure described in the TPS section. To mount the transmission to the chassis requires drilling the RC10 chassis. Bullet provides an excellent fiberglass template for this task. Screw the template to the chassis and drill as instructed. The transmission is well designed but the pot metal diff gears and plastic sprockets concern me - let's see how it stands up to the brutality of serious competition. Oh yes, the instructions need to be reworked to improve their clarity but they will guide you through the assembly process.

JCAR Tranny/Diff

The JCAR diff is the only direct drive unit available at the time of this evaluation. It can be used with the HyperDrive system or with traditional spur gears. It is by far the simplest of all the units evaluated. Basically it is an MIP diff mounted between two aluminum brackets. The diff has a very smooth action and the even take-off of a MIP tranny. I like this tranny best for 2WD direct drive oval racing. It allows the RC10 to compete against RC10Ls, Eliminators and TRC 10s.

Associated Update

Associated hasn't been waiting idly. As we all know, they have developed new idler gears for their transmission and a host of modification parts are available to improve the performance of this transmission but the most important change of all is about to be made available - look for a new transmission from Associated in the late Spring/Summer time frame.

Conclusion

For off-road, the MIP trannies are tough to beat on slippery tracks and the new gear diff ver-

PRO-LINE RED HOT

NEW

Now **PRO-LINE®** offers the ultimate Monster Truck Racing tires . . . **RED.**

PRO-40

APPLICATION: *Serious competition. All track conditions.*

DESIGN: Mini Pin with Centered Crossbars, Lightweight Natural Rubber Blend.

STOCK NUMBER:

#7040

SPECS: Fits 2.2" Wheel
2WD—Front or Rear
4WD—Front or Rear

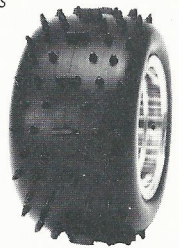

PRO-45

APPLICATION: *Serious competition. All track conditions.*

DESIGN: Multi Rib with Staggered Bars, Lightweight Natural Rubber Blend.

STOCK NUMBER:

#7045

SPECS: Fits 2.2" Wheel
2WD/4WD—Front only



PRO-50

APPLICATION: *Serious competition. Medium to hard pack conditions.*

DESIGN: Mini Pin with Staggered Crossbars, Lightweight Natural Rubber Blend.

STOCK NUMBER:

#7050

SPECS: Fits 2.2" Wheel
2WD—Front or Rear
4WD—Front or Rear



Racing To Bring The Best.

PRO-LINE RED

Race Engineered Design

P.O. BOX 465, BEAUMONT, CA 92223
(714) 849-9781

SEND \$2.00 FOR OUR FULL LINE CATALOG

sion is so smooth it can't help but be a winner. I've been using the TPS tranny on those occasions when I wanted a "locked down" diff for those high traction tracks, it's a tough unit. For gear box 2WD oval I've been using Bullet's diff in the dirt and Track Masters for asphalt/concrete. This sounds like a lot of trannies but keep in mind most racers don't race in all of these conditions. Select the tranny that best suits your racing environment.

Many of the kits do not include diff grease or bearing lube. For diff grease I like VRP's Lubridiff No. 928 diff grease and for bearing lube I use SCAT No. 3503 Bearing Oil. For cleanup I use SCAT No. 3400 Motor & Bearing Cleaner.

'Til next time, GOOD RACING!!

Associated Electrics
3585 Cadillac Ave.

Costa Mesa, CA 92626
(714) 850-9342

Bullet Racing Products
14435 Tomball Parkway
Houston, TX 77086
(713) 444-2267

JCAR
52 Perkins Ave.
Norwick, CT 06360
(203) 887-6476

MIP
838 Edna Place
Covina, CA 91723
(818) 339-9007

Race Master
P.O. Box 5010, Drawer 256
Spring, TX 77383
(713) 668-1253

SCAT Racing Products
20029 Labrador St.
Chatsworth, CA 91311
(818) 885-7228

Team Losi
1655 E. Mission Blvd.
Pomona, CA 91766
(714) 590-0088

Team Pit Stop
12233 S.W. 132nd Ct.
Miami, FL 37186
(305) 255-2887

Track Master
10450 Friars Rd.
San Diego, CA 92120
(619) 562-6331

VRP
4555 Groves Rd., No.15
Columbus, Ohio 43232
(614)861-4555

Transmission Specifications

KIT:

Manufacturer MIP
Model SP-1,SP-1HD
Type Gear drive/ball diff
Instructions Very Good

GENERAL:

Weight (with spur) 3.0/2.8 oz.
Bearings/Bushings Bearings
Ratio 2:1

COMMENTS:

Excellent transmission. Use on low traction tracks.

TO FINISH FIRST, FIRST YOU HAVE TO FINISH!

- We do our own injection molding and control the quality. Every gear we sell is round and concentric, so the gears mesh is easy to adjust.

- They are molded from high temperature Teflon lubricated virgin nylon, to last longer and run friction free.

- The 12 ball bearing hole circle and Teflon lubrication make it easy to get a free running differential adjustment, so your car gets more tire bite when powering out of the corners. Our gears can be purchased with or without 12 ball bearings pre-installed.

available through dealers & distributors

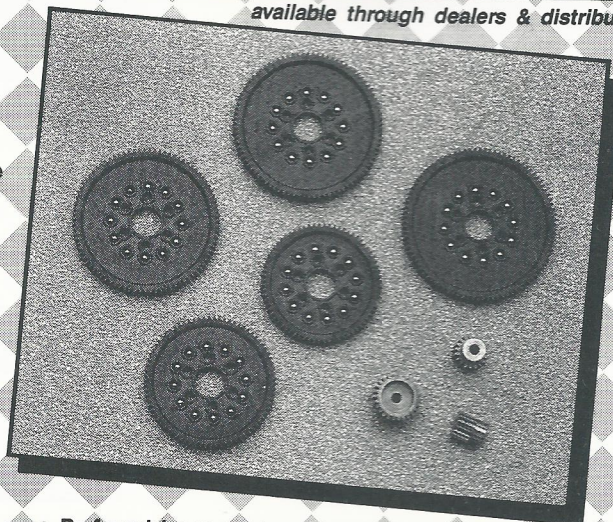
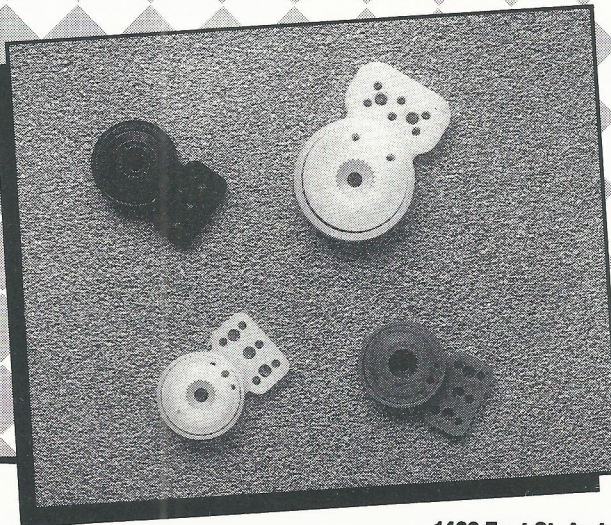

- Preferred by many top drivers & teams.
- 48 pitch pinion gears for 1/12 & 1/10 scale RC cars. Precision machined.
- KP to Mid optima gear adaptors.
- KP to JRX2 gear adaptors.

Kimbrough Servo Saver's Choice
of World Champion's to Club Racers



KIMBROUGH PRODUCTS

1420 East St. Andrew Pl., Unit F • Santa Ana, CA 92705 • FAX (714) 557-4609

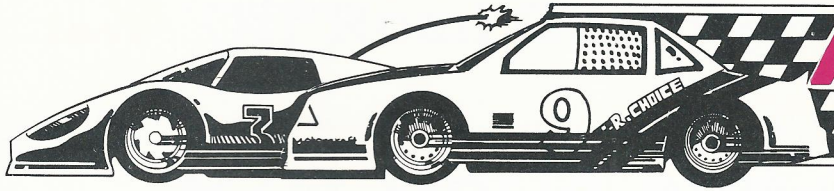

RACER'S CHOICE



**NEW!
LONG
LASTING
FORMULA**

TQ Tire Traction Compound #7011

- Provides ultimate acceleration
- Great control thru every curve & corner
- Reduces tire wear - re-conditions old tires
- All-natural ingredients
- Pleasant, non-harmful lemon-orange fragrance
- Use on carpet, asphalt or concrete
- Perfect for flat chassis, oval and on-road courses



RaceSolv-#7013

- Cleans and degreases without condensation
- Excellent on Bearings and Bushings
- Superb quality Motor Spray
- Leaves no residue
- Full 20 ounce net weight

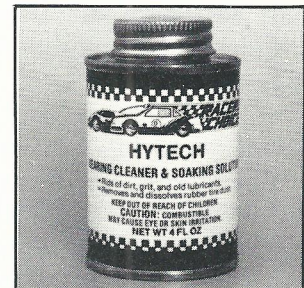

Hytech Bearing Cleaner & Soaking Solution-#7012

- Eliminates speed robbing dirt & grit
- Dissolves old worn-out lubricants
- Removes rubber tire dust
- All-natural ingredients
- Returns bearings to like-new condition
- Saves high cost bearing replacement



**NOT FOR
EVERYONE
ONLY THE
BEST!**

HySpin+ Gearbox, Differential & Disc Lube-#7016

- Outstanding lubrication performance
- Stands up to more hostile conditions
- Superb for all gearboxes
- Forms no gummy or solid contaminants
- Won't attract dirt and grit



HyRev Speed Drops-#7014

- Highest quality motor performance additive
- Use on stock & modified DC motors
- Increases RPM - lowers AMP draw
- Breaks in brushes - polishes comms
- Removes brush glaze
- Improves running time and speed



**NOT FOR
EVERYONE
ONLY THE
BEST!**

HySpin Bearing & Bushing Lubricant-#7015

- Extremely high quality synthetic oil
- Won't form gummy or solid contaminants
- Outlasts & out-performs other lubricants
- Reduces bearing replacement costs
- Attracts less dirt & grit

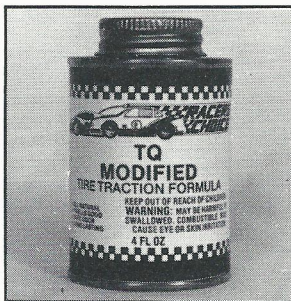

TQ Modified-#7019

- Superb, long-lasting traction
- All-natural ingredients
- Reduces tire wear-re-conditions old tires
- Use on carpet, asphalt or concrete
- Pleasant, non-harmful fragrance
- Maximum bite for heavier transmission cars

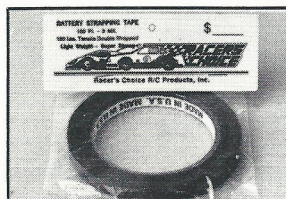

Battery Strapping Tape-#7017

- Race-proven, super strong
- Very light weight, excellent adhesion
- Tensile strength 600 lbs. triple wrapped
- Great for strapping in car batteries
- Ideal for making battery packs
- 180 feet per roll

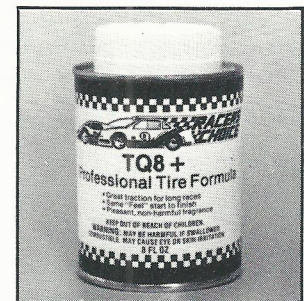

TQ8+ Professional Tire Formula-#7018

- Great traction for long races
- Same "feel" start-to-finish
- Pleasant, non-harmful fragrance
- NO petroleum distillates
- Ideal for 1/6 and 1/12 on-road courses

Racer's Choice R/C Products, Inc. • P.O. Box 405 • Medinah, IL 60157
For more information call: (708) 980-4863 or FAX# (708) 980-5420

Transmission Specifications

KIT:

Manufacturer MIP
 Model SP-1 PLUS
 Type Gear drive/ball diff
 Instructions Very Good

GENERAL:

Weight (with spur) 2.7 oz.
 Bearings/Bushings Bearings
 Ratio 2:1

COMMENTS:

About to set a new standard.
 Excellent all around tranny.

Transmission Specifications

KIT:

Manufacturer Track Master
 Model TRM-4100
 Type Belt drive/ball diff
 Instructions Good

GENERAL:

Weight 3.5 oz.
 Bearings/Bushings Bearings
 Ratio 2.25:1

COMMENTS:

Good transmission for oval.

Transmission Specifications

KIT:

Manufacturer JCAR
 Model DDS
 Type Direct drive/ball diff
 Instructions Good

GENERAL:

Weight 2.7 oz.
 Bearings/Bushings Bearings
 Ratio 1:1

COMMENTS:

Great oval transmission.

Transmission Specifications

KIT:

Manufacturer Team Pit Stop
 Model 9030
 Type Chain drive/ball diff
 Instructions Very Good

GENERAL:

Weight 2.8 oz.
 Bearings/Bushings Bearings
 Ratio 1.87, 2.0, 2.14, 2.28:1

COMMENTS:

Excellent transmission.

Transmission Specifications

KIT:

Manufacturer Bullet
 Model Belt Drive
 Type Belt drive/gear diff
 Instructions Fair

GENERAL:

Weight 4.0 oz.
 Bearings/Bushings Bearings
 Ratio 2.15:1

COMMENTS:

Good oval transmission. Needs work to make smooth.

Transmission Specifications

KIT:

Manufacturer Associated
 Model RC10
 Type Gear drive/ball diff
 Instructions Excellent

GENERAL:

Weight 3.5 oz.
 Bearings/Bushings Bearings
 Ratio 1.87:1

COMMENTS:

Good all around tranny.
 Needs work to make smooth.

THE FUTURE, NOW!

WITHIN ONE YEAR: Every manufacturer of competitive 10" scale off road cars will introduce transmissions with slipper clutches. They will try to copy different designs and components incorporated in our race proven T.P.S. Chain Drive Transmission with Slipper Clutch. However, these transmissions still won't compete because they will be gear or belt driven with higher rotating mass and more friction (both static and under load).

GET SERIOUS: With a race record to back it up; T.P.S. Transmissions have now won national, regional and state titles in dirt oval and off road championships throughout the U.S.; The competition has to catch up. We are there, and getting further ahead each day.

Winners run T.P.S. Chain Drives, losers run something else.

RC-10 Transmission with Slipper Clutch

#9030S \$129.99

Ultima Transmission with Slipper Clutch

#9031S \$134.99

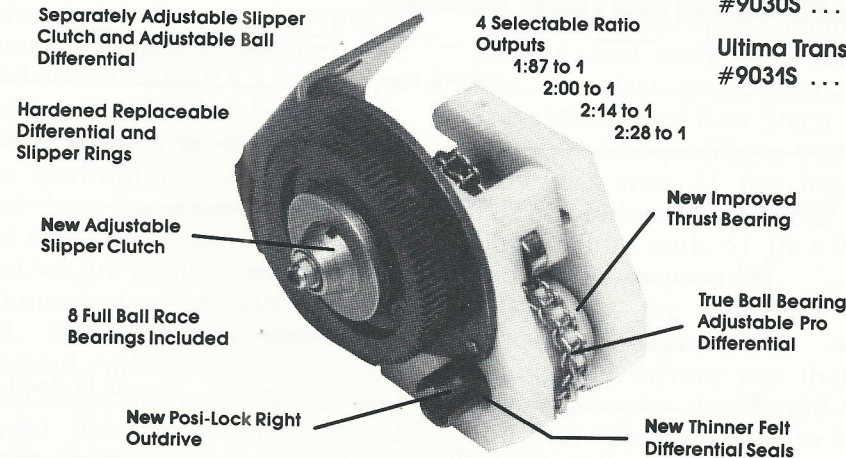

12353 S.W. 132nd Court Miami, Florida 33186
 305/255-2887 FAX: 305/255-2970

WARNING: The Surgeon General has determined that this transmission can be hazardous to your competition's health.

ARCAR proudly presents:

The 1990 Region II 1/10 Dirt Oval Championships

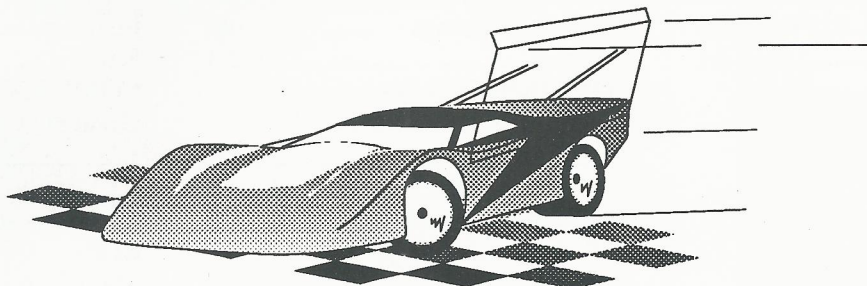

August 3rd, 4th and 5th

Classes:

2WD Stock (handout motors) & 2WD Modified
4WD Modified & Outlaw Sprint Cars
(Limit 2 entries per person - race limited to 250 entries)

Schedule:

Friday: practice, 1st round qualifying
Saturday: 2nd and 3rd round qualifying
Sunday: best appearing car and all mains

Entry Fee:

\$35 for each modified class
\$45 for stock class
(includes 1 motor - additional motors \$15 - limit-3 per entry)

Rules:

ROAR approved closed wheel wedge bodies
(except for sprint cars)
ROAR rules apply
ROAR membership required
(you may join at the race)
ROAR sanction #029009

For more information call (404) 366-4922

Print Name _____ ROAR Number _____

Address _____ Phone () _____

City & State _____ Zip code _____ Sponsorship (if any) _____

2WD Stock - Frequencies 1st _____ 2nd _____ 3rd _____

2WD Modified - Frequencies 1st _____ 2nd _____ 3rd _____

4WD Modified - Frequencies 1st _____ 2nd _____ 3rd _____ Amount Enclosed:

Outlaw Sprint - Frequencies 1st _____ 2nd _____ 3rd _____

Send all entries to: ARCAR South 5281 Germain Ind. Ct. Ellenwood, GA 30049

(Continued from Page 66)

140 to 160 scale miles per hour, with the fastest qualifying lap having been around 188 scale miles per hour. Most drivers were running a conservative race, with battery time and motor/speed control endurance being the biggest worry. As pit stops started (around five minutes into the race), actual pit times ranged from 15 to 30 seconds for battery change only. Some teams required other changes, which took longer and put them behind in the overall lap count. During the course of the race, there weren't too many crashes. However, after the race, the wear and tear on the cars was evident on each and every one from top to bottom! At the start, all of the bodies had new paint jobs and were con-course quality, wheels and tires were trued and un-scuffed! A race of this magnitude certainly puts the cars, drivers and crew members through the wringer. During the course of the race, the following items were retired (either lost, worn out, burned out or just plain disintegrated!): three motors, one speed controller (brakes were zapped!); pinion gears, battery holders, body clips and countless miscellaneous nuts and bolts.

In the final tally, the winning team had 306 laps within the two hour, twenty four minute time period, which calculates out to 183,600 feet, or 34.772 actual miles!! The other cars varied in final lap counts which ranged from 305 to 225 laps (due to pit times required to repair/replace/mend damaged equipment). We had done it! SIMRA's first major racing event was a big success. Everyone was so excited about the performance of this event that there was already talk about the next race, (bigger and better) that we are going to put on. Preliminary plans are already started, with at least one more on-road endurance race, an off-road race, and possibly dirt and paved oval races with several classes of racing each. We now

know how to make it happen: with lots of volunteer time and effort. If your club has been considering a large race event like this one, don't think about it . . . Just do it!!! (sorry Nike!) Good luck, and we hope to hear from other clubs when they are ready for their BIG ONE!!!

(For more information regarding how we did it, and future race events you can call (812) 275-7568 (Copy Hobby Center evenings only) or the author at (812) 279-1525 (evenings) and we'll try and help you any way we can!).

SARCAR DOES THE PULLYALLUP

By Bob Miller

There was no regional, national, or world title at stake. There were no big name drivers, no factory support, no sponsors or endorsements. It was just the locals, doin' the Pullyallup. This is their story.

The Northwest Model Exposition is held at the Western Washington Fairgrounds, in Pullyallup. The last few years, SARCAR members put on a exposition of 1/12 scale indoor racing. The track was designed by club member Sherman Joseph. It was a combination of speed and torque, with a nice straight-away, followed by a couple of 180s, and a series of cutbacks which were just a hair too tight to be called esse curves.

During the first hour of open practice, most drivers adapted nicely to the challenging track. There was good speed, plenty of passing, and early on it looked like the fast guys were Jeff Travelstead, and Ron Steen. The first round of qualifying had Jeff turn in a nice 51 lap heat in 8:02.01, followed by Ron, and Chris White with 51 in 8:02.44 and 8:04.95, respectively.

Back to the pits and the thrashing began. The word among the drivers was that 51 wasn't going to do. Round two, and Ron upped the ante to 52 in 8:03.80, followed by Jeff with 52

AUTOSCORE

The ultimate race scoring and race management program

- Menu driver - user friendly
- Quickly resolves frequency and number conflicts
- Sets up heats and mains in minutes
- Scores all qualifiers and mains by racer's name
- Will score up to 10 qualifiers and 1 main for each racer
- Can handle up to 1000 racers in 30 classes
- Prints complete standings by name or position
- Positions, lap times and speeds continuously displayed
- Runs on IBM pc or Compatible
- Only \$250, PRO version \$450
- Can be used with the AMB scoring system
- 1/4 scale version also available

Used by
R/C SPEED WEEK
NORRCA
R/C THUNDERDROME
AND MANY MORE

Send for FREE demonstration disk
(Include \$1.00 for shipping & handling)
B & B Software - 2146 Palomar Ave
Ventura, Ca 93001 (805) 643-2042

in 8:07.18. The racing was clean, but there was still more potential, and the pits were sizzling with action.

Chris put it together in round three with the TQ run, turning heads with a stunning 54 (that's right, fifty-four laps) in 8:02.55. Chris' impressive run really got the spectators going. The final qualifiers for Saturday saw Ron, and Steve Curry turn in 53s at 8:04.62 and 8:08.33 to finish second and third in qualifying for the day.

Sunday's crowd was just as large, swelling to nearly 200 spectators. The day also saw more displays of solid speed. Steve backed up his previous 53 with a 54 in Sunday's first round of qualifying. After two rounds, the field was set, and Chris' TQ from Saturday held up, followed by Steve with his 54, and Ron and Jeff with their 53s. Roger Moore and Brian Bodine qualified for the A main, with Gary April bumping up from the B.

The field was set and the real racing began. The first four minutes of the amateur class was a hotly contested race between Eric Rikansrud and Tom Oberst. The Erik settled down and drove away to win by one lap. Milt Lathan won the expert D main with 47 laps. Henry Cannon won a very close C main, with Terry Varner and Sherman Joseph only two and six seconds behind, all in 48 laps. Henry took the bump and finished third in the B main. Also in the B main, Scott Stevens, Eric Bourlet, and Henry Cannon kept the crowd on their feet for the first three minutes. While they swapped paint and the lead several times, Gary April patiently passed each one of them for a very clean 51 and the bump, followed by Eric and Scott.

Now the A main was set. Up to now there had been two awesome 54 runs, several 53s and 52s. This was an exceptionally fast field,

the odds on favorite was Steve Curry with Chris White not far behind. The field lined up LeMans style, and Chris led them through the first three turns, before clipping the board. The field scattered and all seven drivers adjusted instantly. There was no major pileup and out of it came Chris and Jeff racing hard for the lead with Steve and Ron in the hunt.

The tone for the race was set, it was super clean with mature and considerate driving. Each driver was patient and passed with care. Ron pushed forward, pressured by Steve. Ron went wide and Steve was by him. Chris and Jeff raced hard into a turn and Jeff came out in the lead. Steve continued his march to the front using speed on the straight with clean and tight lines in the turns. His tight line gave him the lead at the start/finish line when Jeff went wide out of turn ten.

At the halfway point of the race only two questions remained. Who would make a mistake? How much battery was left? The answers came over the next four minutes. No one made a mistake. There was "just enough" juice in the batteries. Steve Curry yelled, "How much time is left?" And with two minutes to go, everyone focused on the gap between first and second. Was it changing? Was the leader slowing? Nah . . . just checking, that was all there was to it. This race was so close and clean, that it produced the fastest times of the weekend. Steve turned in a stunning 55 in 8:05.77, followed by Jeff, also with a 55, and in 8:07.40. Chris was third with 54 in 8:10.56.

It was cold outside, but the inside racing was hot. A group of local guys tweaked and tuned, drove their best, and showed a crowd of modeling fans what it was all about. The Pullyallup

Keep it cool!

When the competition is hot... you have to keep your cool! So do your brushes and motor. For this reason, CLASS Recreational Products designed the new *Venturi* brushes. When installed correctly, the spinning commutator actually creates a vacuum (venturi effect) over the hole in the center of the brush. This venturi effect pulls cool air in from the outside of the motor keeping the commutator and brush tip cooler. Result... less glazing and better commutator life. Look for the CLASS venturi, cut, and full brushes in both stock and modified compounds at your dealer today.

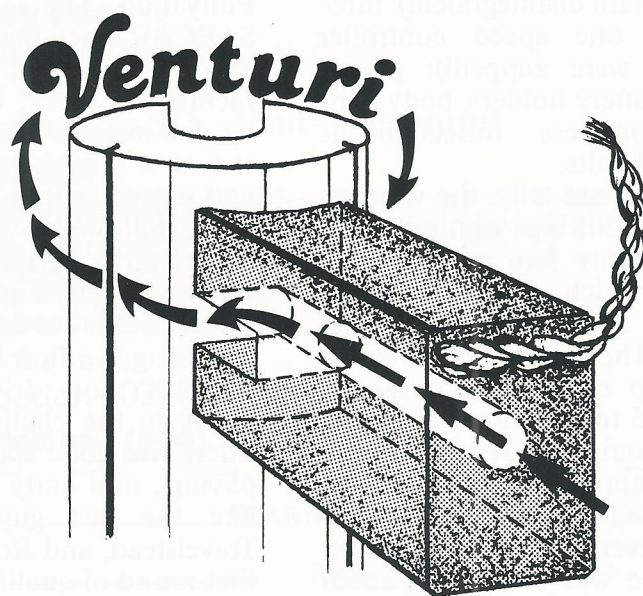

Class Recreational Products
RD #1 Box 187A
Utica, NY 13502
TEL. (315) 724-8052



TRY THIS
WITH ANY
OTHER CHARGER!



You *WONDER* why Class can offer a one year warranty?

At Class Recreational Products, we believe an important feature of a charging system is durability. We test our chargers by shorting the leads and starting the charging cycle. Our chargers can handle this abuse and we offer a one year warranty to prove it.

The MODEL 188 soft pulse charger charges 1 to 8 cells at up to 8 amps and breaks in motors while providing peak detection, peak sensitivity control, and trickle enable/disable.

All of these features come in one small 120 VAC powered package without the need of those costly fans, power supplies or specialized chargers.

The Class MODEL 188 charger is the premier item in a broad line of recreational products built with the same dedication, ingenuity, and product knowledge that go into the design of mini and micro computers.

Here are some comments we've received:

Don Brown of STAGE III, THE ULTIMATE CELL TEST — "We have evaluated and we endorse the Class MODEL 188 charger. The charger is the best AC charger we have seen and tested, it is excellent for indoor racing. No other unit offers all the convenient features of the Class charger."

Bob Light (World Class Driver and National Champ) — "... convenience and performance, it's great!"

Frank Calandra (1989 Speedworks Sportsmans Cup and Region I Champion) — "... No fans, no power supplies, no false peaks, less junk to carry. All this in such a small package! Charge with Class, it works!"

Available from Horizon Hobby Distributors or your local dealer.



Class Recreational Products, Inc.
RD 1, Box 187A
Utica, NY 13502

Telephone (315) 724-8052
FAX (315) 732-2034

"THE BEST OF THE BUNCH"

Second Annual Rocky Mountain Championship Races

Hosted by R/C World and Track

2788 S. Federal Blvd. • Denver, CO • (303) 789-0838

Home of Region V Offroad Championship Races - August 10, 11, 12

Sponsors include: PARMA, VRP, Twister

OFFROAD — July 14 and 15

(Sat starts 1:00 p.m. • Sun Starts 1:00 p.m.) Saturday - 3 Heats • Sunday - 1 Heat & Main

OVAL — July 20 and 22

(Fri starts 7 p.m. • Sun Starts 12:00 p.m.) Friday - 3 Heats • Sunday - 1 Heat & Main

ENTRY FEE: \$35.⁰⁰ Stock (includes stock motor)
\$25.⁰⁰ Modified

★ FREE Merchandise from Manufacturers ★ B&B Software ★ AMB Lap Counting

ENTRY FORM

Name _____

Address _____

City _____ State _____ Zip _____

Phone (_____) _____

OFFROAD ENTRIES
must be received by July 8

OVAL ENTRIES
must be received by July 13

\$5.⁰⁰ Late Fee

OFFROAD • July 14 and 15

- Stock Plastic Chassis Monster
- Outlaw Monster
- 2WD Stock
- 4WD Stock
- 2WD Modified
- 4 WD Modified
- Car type _____
- Frequency 1) _____ 2) _____ Must have 2 frequencies
- T-Shirt Size Small Med. Large X-Large
 XX Large XXX Large

OVAL • July 20 and 22

- Stock Plastic Chassis Monster
- Outlaw Monster
- 2WD Stock 4WD Stock
- 2WD Modified
- 4 WD Modified
- 2WD Sprint Open
- Car type _____
- Frequency 1) _____ 2) _____ Must have 2 frequencies
- T-Shirt Size Small Med. Large X-Large
 XX Large XXX Large

isn't part of the Big Guy Circuit, but it's a blast! I'll be back next year, and I hope to see you there.

Main

- 1st - Steve Curry
- 2nd - Jeff Travelstead
- 3rd - Chris White
- 4th - Roger Moore
- 5th - Brian Bodine
- 6th - Gary April
- 7th - Ron Steen

B Main

- 1st - Eric Bourlet
- 2nd - Scott Stevens
- 3rd - Henry Cannon
- 4th - Rich Blake
- 5th - Dave Clark
- 6th - Les Handy

C Main

- 1st - Terry Varner
- 2nd - Sherman Joseph
- 3rd - Stan Pang
- 4th - Mark Anderson
- 5th - Lee Robertson

D Main

- 1st - Milt Lathan
- 2nd - Ed Hagan
- 3rd - Dave Mapston
- 4th - Bob Miller
- 5th - John Aquino

Amateur
A Main

- 1st - Erik Rikansrud
- 2nd - Tom Oberst
- 3rd - Mike Liem
- 4th - Paul Moss
- 5th - Matt Clark
- 6th - Jess Robertson
- 7th - Randy Aquino

B Main

- 1st - Shane Gentry
- 2nd - Gary Gentry
- 3rd - John Raup
- 4th - Robert Cannon

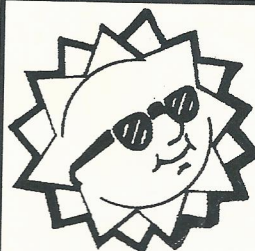

HEY DUDES...
CHECK OUT DIALED'S
Excellent R/C
STUFF!!!

\$29.95

NEW LOW PRICES - MOST EVERY ITEM

Team
DIALED
Racing Products

Machined Aluminum, Lifetime Guaranteed Suspension Parts to aid the motion of your JRX-2's, YZ-10's, Lazars, RC-10's & JRX-T's...



No more of those Bogus Speed Controls!

The whole *DIALED* line is Reverse Voltage Protected! From the 90 amp stocker to the track stomping 360 amp model Featuring High Frequency Pulse Efficiency and Smoothness that makes for Driver Control

NEED SERIOUS POWER???

There's the new 720 amp MONSTER MASH for you monster truck fans!



That *Need For Speed* starts with *DIALED's* Super Punchy, Voltage Matched, G-Max Batteries
Check out These Winner's Circle Secret Weapons!

DIALED RACING PRODUCTS

122A EFFEY ST. • SANTA CRUZ, CA 95062 • (408) 723-7868 • FAX: (408) 423-2948
Catalogs (\$1) • Tips • New Items... Call or Write!!

All Orders
Shipped
Same Day

WAGONHILL HOBBIES



(412) 458-4711

225 S. Broad St., Grove City, PA 16127

>Over \$50 Shipped
Free in U.S.
>Mastercard / Visa
Discover
>C.O.D. Available

*Just Getting
Started?*

Let us help sort out
your questions about
this exciting sport.
Call Us!

Sale Prices On:

- >RC10 Kits - World Champ!
- >MRC Tamiya Kits - Easy Assembly
- >Truck Kits - Most Popular for new RC'ers

OR

ASSOCIATED
ADVANCED
ANDYS, BUDS
COMPOSITE
CRP, DANS
DIALED R.P.
HOUGE, IMEX
LIGHTSPEED
MRC TAMIYA
PROG. TEC.
RACE PREP
SHINWA, TEKIN
VICTOR, NOVAK
ZETA & MORE

Heavy Into
Competition?

We've got the parts to let you go
faster. Batteries, Chargers, Motors,
Electronics, More.

New:

- >Tekin 210 - Reflex Charger
- >Prog. Tec-Supergold Batteries
- >Power Supplies - Pyramid

FAST FRIENDLY SERVICE WHEN YOU WANT IT (412) 458-4711

VICTOR OR VICTIM

IN EVERY RACE THERE ARE VICTORS AND VICTIMS - WHICH WILL YOU BE? FOR YEARS PARMA HAS BEEN PRODUCING WINNING, MATCHED AND SUPER MATCHED SANYO BATTERY PACKS FOR RACERS LIKE YOURSELF, WHO ARE SERIOUS ABOUT WINNING. VICTOR OR VICTIM? THE CHOICE IS YOURS. JUST REMEMBER, WHEN THE DUST CLEARS, PARMA SANYO SCE'S ARE THE WINNER'S CHOICE.

SHOWN ARE PARMA SANYO SCE'S AVAILABLE IN A VARIETY OF PACKS AND CONFIGURATIONS.

SANYO



PARMA SANYO SCE HIGH RATE DISCHARGE CHARACTERISTICS

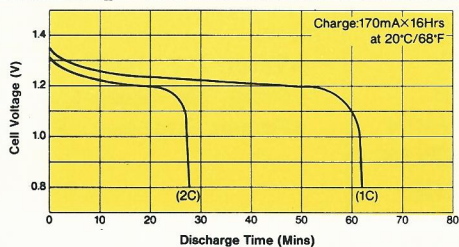

Parma regrets we cannot supply individual orders on a retail basis. For parts and information, contact your local Parma dealer. SEND \$3.00 FOR A FULL COLOR CATALOG.



parma
INTERNATIONAL INC.

13927ECP Progress Parkway, North Royalton, Ohio 44133
LOOK FOR US AT THE RCHTA SHOW!

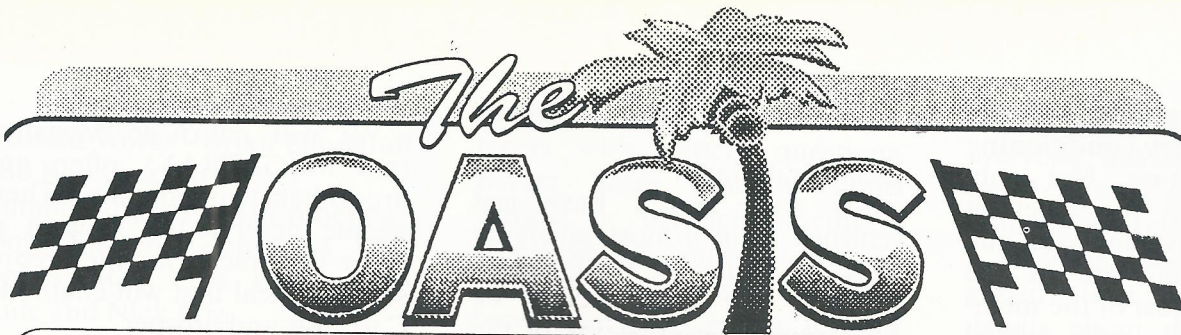

HOBBY PARK ★ HOUSTON ★ REMOTE CONTROL RACING & MORE!

PRESENTS the

1990 ROAR REGION FOUR 1/10 DIRT OVAL CHAMPIONSHIP AUGUST 3, 4, & 5, 1990

SPONSORED BY

**T.O.S.C.A. - CHU MANUFACTURING - PROCELL MOTORS & BATTERIES
BULLET RACING PRODUCTS**

Accommodations are provided by LEXINGTON HOTEL SUITES (713) 821-1000

*** ROAR Membership Required (Available at The Oasis)

*** Entry Fee: Mod \$30.00

Stock \$40.00 includes 1 Stock Motor
(1st additional motor \$15.00
2nd additional motor \$20.00)

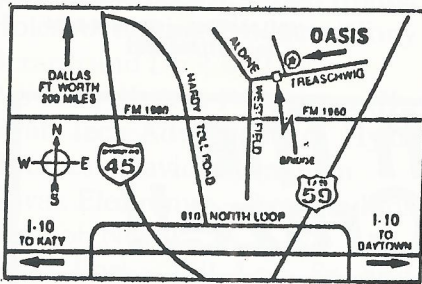

3 Qualifiers. Weather Permitting

Schedule: Friday - Open Practice
Saturday - Concourse and Stock
Sunday - Concourse and Mod
Monday - Rain date

*** ROAR OVAL RULES APPLY

***Note for Novice: This is an entry level class. You cannot enter any other classes if you sign up for Novice.

*** FOR MORE INFORMATION CALL (713) 443-6003

*** Send entry fee to THE OASIS HOBBY PARK-HOUSTON
4307 Treaschwig Road
Spring, Texas 77373

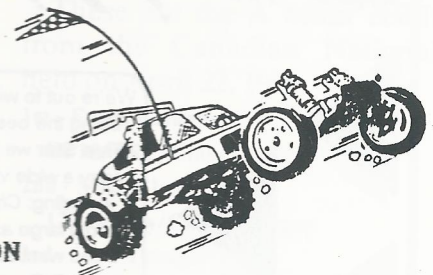

ROAR SANCTION #4-90-18

Limited to first 250 entries

NAME _____ ROAR # _____

ADDRESS _____ PHONE # _____

CITY _____ STATE _____ ZIP _____

Saturday	2 WH STOCK _____	FREQ: 1st _____ 2nd _____	Sunday	2WH MOD _____	FREQ: 1st _____ 2nd _____
	4 WH STOCK _____	_____		4WH MOD _____	_____
	STOCK TRUCK- 2 WH ONLY _____	_____		SPRINT MOD _____	_____
	2WH HOT ROD _____	_____		OPEN TRUCK- 2 OR 4 WH _____	_____
	(SPECIAL CLASS - CALL FOR RULES)				
	2 WH Novice _____				

with basic information such as motor care, battery conditioning and chassis set-up. Not only would this help the racer, it would give the average local guy a reason to join one of the organizations. Most of the members I've spoken with joined because they had to enter the race we were at. Other than that entry and maybe a Xerox copy of some "rules" there was no reason to join.

As far as motor information goes. (let me say this and I promise to shut up). Mike Walker of Twister Motors has an excellent motor tuning guide available free for the asking. It dispels many of the myths associated with these little marvels, and is quite informative. Look for his ad and call the number listed - it is definitely worth it.

Thank You,
Matt Wall
 Slidell, LA

PRAISE!

Dear Mr. Barana:

My sons and I have just returned from a most satisfying weekend of racing at Megatrak, probably the finest facility we have raced. The real joy of the track is not just it's magnificence, but the attitude and dedication of Ed and Tony Angiuoli, and their family.

You probably would count me in the minority; I am thankful for ROAR, I like John Thawley, (what he says and represents), and I am not interested in using R/C car racing to get rich. There are few, I feel, that share that attitude, saying win the "A" Main, then sell your battery packs for \$80. But, I feel perhaps the most selfless individuals are running Megatrak, more concerned for racers than profit. People who, with a captive audience, sell Megadogs for a dollar, should both be acknowledged and applauded, for

they are rare indeed.

We will return to Megatrak (not MEGATRAX), often and urge others to do the same. These people deserve the support of every R/C racer, for they represent the ideal that will enable R/C to grow and prosper.

Again, a tip of the hat to Ed and Tony, and thanks!

Sincerely,
Francis J. Cupka
 President
 C.A.R.S.



**Be a
 winner with
 Hyperdrive**
Racing Systems

Hyperdrive kits and accessories are available through popular hobby shops and distributors.

For parts, catalogs (\$3) with free stickers, or more information, call factory direct.

3210 Howard Nickell Road • Fayetteville, Arkansas 72703
 Phone (501) 444-8200 or (501) 444-8494
 Fax (501) 444-8402

Five Star
Manufactured by Sunbeam

**Catch The
 Latest Craze!!**

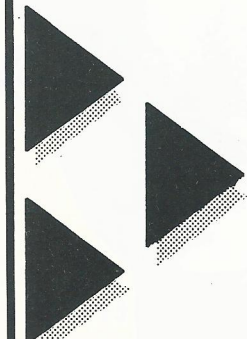

We're out to win you over to **Five Star**. Being the best isn't easy but here at **Five Star** we are doing our best! We carry a wide variety of R/C equipment including: *Chargers, Battery Packs, and a large assortment of lubes.* So if you want to keep up with the best in the R/C world you have to use the *best you can get for your money!!!*

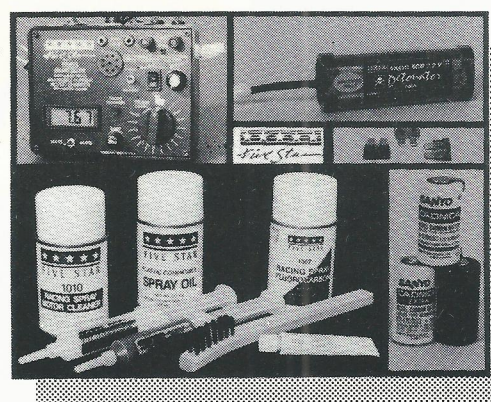

Send \$2.00 for a complete catalog and receive a \$2.00 value DECAL SHEET, FREE!!to:

3640 Milwaukee • Port Huron, MI. 48060 • 313-385-4550 / Fax 313-385-4302

(Continued from Page 22)

Custom Works - Brian Landgraff and Rob Cuttman
Futaba Corporation of America - Donn Rice and Glen Toma
BoLink R/C Cars, Inc. - Steve Rule and Nick Piro
Parma - Paul Marzinni and Larry Bishou
Tech-Toys - Joe Scarbrough and Chad Jeffrey
VRP, Inc. - Steve Verona
Hyperdrive - Bill Morton
Fine Design Mfg. Co. Inc. - Rich Roth and Chris Fine
M.R.P. - Bob Welch and Ross Rainville
Racing Silks - Janet Parodi and Sue Dalessio
Bob Smith Industries - Bob Smith
Stroker Products - Charles Notabartolo and Ron Boorman
Peak Performance - Rick Hohwart and Derek Furutani
Braun Hobby Dist. - Todd Braun
Holeshot Racing Products - Tony Berardi and Dick Ballantyne
Pro-Line - Wylder P. Barrows III
Hyatt Tech Advanced R/C Hyatt Hobbies - David Eltringham
Novak Electronics - Tyree Phillips and Bob Novak
Team Losi - Gil Losi Sr. and Gary Kyes
J.G. Mfg. - J.G. Sr.
Inter-Fab - Anthony Severino and Chris Bertotti.

Between 1:30 and 2:30 p.m. on Sunday, Great Planes sponsored an amateur I.R.O.C. - local DJ Bobby Sharp of WOGL raced listeners and show attendees for T-Shirts.



NEW ACQUISITION

Team Smooth Inc. is pleased to announce the acquisition of Louis LeBlanc to its operating staff. Louis will handle the west coast sales and promotion of Team Smooth's matched batteries. He will also be attending all major races to promote the

products and to help fellow racers with battery questions. Before Team Smooth, Louis worked for Advanced Racing in El Cajon, CA where he was the production supervisor. Louis has been racing R/C cars for ten years and has worked in the RC industry for two years.



NORRCA ANNOUNCEMENT

Since NORRCA started in 1987 one of our main goals has been to promote family oriented racing. In keeping with that concept, NORRCA is lowering the annual membership fee for racers 12 and under. The annual fee for racers 12 and under will be \$10.00. NORRCA is hoping that this will encourage families to participate more actively in their local track activities.



PARMA CYCLONE II INVADES THE EAST COAST: THE PARMA CYCLONE II REGION 1 OVAL CHAMPIONSHIPS

This July 7th and 8th, Parma International, in cooperation with Megatrak of Browns Mills, New Jersey will host the ROAR Region I Oval Championships.

According to Ed Angiuoli (who owns Megatrak Raceway with his brother Tony), "This promises to be the biggest race of the year". Each week Megatrak pulls in 150-160 racers all wanting to take advantage of the state-of-the-art facilities, and this Parma sponsored race promises to double that figure.

Adding to the excitement of this race, is the fact that all racers will be using the highly acclaimed Parma Cyclone II ROAR Stock Motor. This motor is definitely the most consistent motor available, ensuring a lot of close, competitive racing.

The Parma ROAR Region 1

Oval Championships is open to everyone, but includes only 1/10 and 1/12 scale pan cars in stock and modified classes.

Additional classes may be added later. For additional details about this race or to receive Megatrak's newsletter watch for advertisements in your favorite R/C race magazines, or contact Megatrak at:

Megatrak
521 Lakehurst Rd.
Browns Mills, NJ 08015
(609) 893-7716

We'll see you at the track!!!



TEAM CLASS COVERS CANADA

Team Class driver Frank Calandra won the 1990 Canadian 1/12 scale Nationals in Toronto, Canada using the new Venturi brush and the Model 188 charger. A total of 4 A Main drivers used the Class charger including the second place car of Mike Ebert. A Special thanks to Sam Burke and crew for a well run event.



CANADIAN NATIONALS

These are the A Main results from the Canadian Nationals held on April 22, 1990.

- 1st - Frank Calandra
SP12/LRP/Class Charger
2nd - Mike Ebert
12L/Reedy/Class Charger
3rd - Glen Tonagai
Agitator/Twister/Novak Charger
4th - Mike Baker
Agitator/Twister/NA
5th - Willie Decker
SP12/LRP/Class Charger
6th - Mike Blackstock
12L/Reedy/Novak Charger
7th - Tom Lamb
12L/Reedy Novak Charger
8th - Jon Orr
SP12/LRP/Class Charger



RACING TIPS

By Kevin Gray

We all had to start racing at some time. My background ranges from competitive motorcycle racing in enduro and super bike street forays, to racing as a J gas drag car on a semi-pro schedule for several years. In each instance some ideas overlapped, then others definitely did not. No matter what you race there are a few hints that make racing less hectic and more enjoyable. R/C racing is no different, in fact any racer can learn if they keep their eyes and ears open. I watch, listen, and watch some more, to see if what I learned has any credence or not, and if I can apply it to my use. The purpose of these article is to help spread around a tip or two that may help everyone. Some of this may seem old hat to the more seasoned racer, and new to the greener racers, but I feel that we all can learn and improve our sport through sharing. I don't hoard tips, because I want to race, and if a tip I give away improves my competition then my work is cut out for me to get better. That is racing, not some hot dog that runs away with every race and never has competition. Watching Joel, Tony,

Andy or Rick run by himself is not as impressive as if another car is pressing him the whole race. That is excitement and true racing. This is not to tell you that this is the only way to work, in fact, if you have a better way to skin the proverbial cat, or another tip altogether, then send them to me in care of Competition Plus, and we will see it gets used to everyone's benefit. Ask any one, I'm no A main racer, in fact, I'm always a ways down the line, but I learn and improve with each season, and a lot is attributed to the things I learned from others, and PRACTICE.

Remember: The only stupid question is the question never asked! Ask for advice from an assortment of sources, and listen to the idle chatter of fellow racers when they are discussing set-ups. Not every tip will work for every racer, as your driving style is your own, and your car must fit you, not the local hot shot. Be true to yourself, and the R/C experience should be rewarding.

Good Luck! And go FAST!

Kevin Gray

RACING TIPS:

Carry a hand size towel (an old

one will keep you out of the dog house) and spread it out on the working surface. With this spread out prior to setting up your pit area, tool boxes and power supplies will help to hold it in place. The towel will help to cushion dropped parts, absorb dripped motor spray and oils, and capture dropped diff balls and bearings before they have a chance to roll off to that place that they hide, never to be found again. □

Lubrication of moving parts is needed, but sparingly! The shaft bearings of your motor need one drop of 10 weight oil for bearing motors, and one drop of 20 weight oil for bushing motors per end. The bearing motors require more frequent oiling, but do not over do it! Too much oil can work it's way into the motor, and foul the comm. If this happens and is not cleaned out with motor spray soon the comm can burn, rendering your pride and joy trash. There are several lubricants on the market, and using them is worth protecting your investment. □

Competition Plus is always striving to bring you as much information as possible. With this new column we will be bringing you each month, we hope to supply you with little helpful hints all racers can use. If you wish to send in your own racing tips, send them to Competition Plus: RACING TIPS, 16582 Gothard, Unit Q, Huntington Beach, CA 92647. We will send you a Competition Plus T-Shirt for every tip we print.

Modeler's Haven

"Experienced Racers You Can Trust"

Call Us First For Those Hard To Find

R/C Car Parts & Accessories

PHONE (216) 499-6000 FAX (216) 499-6087

PROMPT SAME DAY UPS SHIPPING

VISA - MASTER CARD - DISCOVER CARD

"Leave Others Behind - At The Start Line"

WITH TURBO MADNESS - COMPUTER MATCHED BATTERIES

4255 Portage N. W., North Canton, OH 44720

Racing Schedule

— 1/8 & 1/4 Scale —

OUTLAW MOTOR SPEEDWAY

Every first & third Saturday - 1/4 Scale
Dirt Oval. 7920 Webster, Highland, CA.
Call (714) 864-1770

THE RANCH PIT SHOP

1655 E. Mission Blvd., Pomona, CA
91766, (714) 623-1506. Every second
Sunday.

MACHESNEY PARK RACEWAY

1/4 Scale - Large asphalt Oval racing
every Saturday and alternating Sundays
April thru October. 1220 Shappert Dr.,
Machesney Park, IL 61111, (815) 282-
1311.

CAJON R/C SPEEDWAY

1875 Joe Crosson, El Cajon, CA 92020.
(San Diego County) - Asphalt Oval/
Road - Dirt Off-Road. Race Schedule
Hot Line (619) 449-0788; Track Info (619)
449-9948; 1/12, 1/10, 1/8, 1/4 Scale Rac-
ing. Monthly schedule available at track.
Race Every Sunday, Tues. nite, Friday
nite.

HOBBY CORNER RACEWAY

Large indoor dirt oval track - racing year
'round - 1/8 scale racing Wednesday
evenings - 1/8 and 1/4 scale racing Satur-
days. 2195 E. Garfield, Decatur. IL
62526. (217) 429-4477.

TARCAR-TOLEDO AREA

New black clay tri-oval. 1/18 gas stock
cars. Sundays late April thru mid-
October. For more info call Dave
Scanes, (419) 893-1916.

SMR/CRC

First Sunday of Each Month at G.I.A.
1660 Stewart Street, Santa Monica, CA.
Sign-up 8:30 a.m., Practice 9:15 a.m.,
Qualifying 10 a.m. For more information
call Glenn Williams (213) 734-7888,
Chris Chan (213) 393-3735, Tom Wong
(213) 821-5472.

— 1/10 Scale —

G & S OFF-ROAD RACEWAY

Every Sunday - San Carlos & Meridian
Avenue, San Jose, CA.

KANSAS R/C RACING CLUB

Every 2nd Sun. - Junction City - 1 p.m.
Every 4th Sun. - Enterprise - 1 p.m.

CENTRAL NEW YORK

Lawrence Race Park

2509 Macedon Center Road, Palmyra,
NY 14522. (315) 597-6429. 1/10 and 1/12
electric auto racing. Nov.-Mar. Carpet
racing 1/12 scale. Oval and road racing.
April-Oct.

REECE'S R/C RACERS

1st & 3rd Sundays at Spinner's Airport
Raceway, 2nd & 4th Saturdays at Reece's
R/C Racers. (209) 784-0922.

PANTHORN RACEWAY

Panthorn Park, Burritt St., Southington,
CT. Every Saturday May 1st to Nov. 1st.
Off-Road, Oval, Baja, Truck Pulling.

Call (203) 628-9345 Ben Carr, 272-9326
Pete Church, 237-6976 Bob Lavoie, 879-
2316 Steve Magnani.

R/C HOBBIES RACEWAY

Route 163 Bozrah, CT

Racing Every Sunday - May 1 to Oct. 30.
For more information call: R/C Hob-
bies, (203) 886-9441, ask for Mike or Bob.

R & R HOBBY

We have 1/10 scale dirt tracks both
inside and outside, also 1/12 tracks both
inside, also 1/12 tracks both inside and
outside. R & R Hobby - 1414 N. 24th St.,
Quincy, IL 62301, (217) 228-1133.

HAL'S HOBBY SHOP

Every Saturday from 9:30 a.m. to 4 p.m.
Practice: Track open all week. Hal's
Hobby Shop, 4886-A Hercules, El Paso,
TX 79904, (915) 755-1914.

RIVER CITY R/C OFF-ROAD

Racing is every Saturday, sign-ups 3
p.m., racing starts at 3:30 p.m. (512) 656-
5724 evenings.

MASON DIXON R/C CAR CLUB

Every Sunday at 1:00 p.m. Track location
at Hagerstown Fairgrounds, Hagers-
town, Maryland. Call King's R/C Cars,
219 E. Washington St., Hagerstown, MD
21740, (303) 739-0080.

SNORR

Racing every 1st and 3rd Sundays. P.O.
Box 438, East Haven, CT, (203) 469-2594
or (203) 481-5813, Dave Seales.

TEAM RACE R/C CAR CLUB

Fridays: 6:30 p.m. 1/10 scale 505 Spring
Ridge, Clinton, MS 39056. Call (601)
924-0722.

F/X CITY RACEWAY

Every Saturday 1 p.m. The Frame
Gallery, 13340 F. Franklyn Farm Road,
Herndon, VA 22071. For info call Eric
Zelman, (703) 471-4499.

RIVER CITY RACEWAY

On Quincy Road, Wichita Falls, Texas.
Every 2nd & 4th Sundays at noon. Call
(817) 691-1478.

WALT'S HOBBY & CRAFT

2 Dwight Park Dr., Syracuse, NY 13209,
(315) 453-2291. New 12,000 sq. ft. bldg.
Two indoor tracks. 1/10 Clay Oval, Mon.
6:30 p.m. & Sat. 12 Noon; 1/10 Gearbox
Carpet, Mon. 6:30 p.m.; 1/12 & 1/10 Car-
pet Cars, Tues. 6:30 p.m. Oval and Road
Course; Wed. Evenings Weight Pulling.
Daily Practice. Computerized scoring.

HITT'S HOBBY AND RACEWAY

Tuesdays: Oval Asa, Full Bodies
Thursdays: Off-Road - Stock
Saturdays: Off-Road - Novice
Sundays: Off-Road - Modified
Oval and Off-Road; 853 Wren Rd.,
Goodlettsville, TN 37072. For info call
Ben or Kent (615) 859-3465.

CARCLUB - COCHRANTON AREA

The Carclub races Fridays starting at 6
p.m., Saturdays starting 9 a.m. Sundays
starting at noon. Large indoor carpet -
dirt outdoor. Call for info Harry Turner,
120 W. Adams St., Cochranton, PA
16314. (814) 425-7788.

QUEEN CITY R/C RACEWAY

1/12, 1/8 and 1/10 scale cars. Every
Friday - 7 p.m. -Open Class Every at. -2
p.m. Stock & Open. Every Sun. - 2 p.m.
Drag Racing 5050 S. Federal Blvd.,
Englewood, CO 80110, (303) 730-1391.

PDQ RACEWAYS & HOBBIES

1/8, 1/10, 1/12 Scales

Call times and details. 429 Bankhead
Highway, Mableton, GA 30059, (404)
941-2626.

SROKA'S INDOOR R/C

Racing every Sunday - Oval racing every
4th Sunday. 5216B Arboga Rd., Marys-
ville, CA 95901. Call Michael or Vickie
Sroka (916) 742-6148 or (916) 741-3051.

FLINT R/C CAR CLUB

Flint, MI. Summer: Every other Sun.
from May to Sept., Fall & Winter 1/12 4
cell on carpet. For info: Ralph Herndon
(313) 658-5390 or Tom Hoos (313) 658-
1043.

MILE-HI R/C SPEEDWAYS

Thurs. & Sat. Off-Road, Fri. Carpet,
Sunday 2 p.m. 178 S. Kalamath, Denver,
CO 80221, (303) 722-6766.

AMERICAN HOBBIES

Thursday Night Oval Racing
Sunday Off-Road & Oval
For info call (201) 446-2010.

C.A.R. CLUB

Racing at Tamarack Raceways. Contact
Harry Turner, 120 W. Admans St.,
Cochranton, PA 16314, (814) 524-7788.
Racing every Sunday.

ARROW HOBBIES

Wed. Nights - 1/10; Every other Fri.
night 1/8 Sprint Cars only; Sat. nights 1/
10 dirt oval. 2710 So. I-35 West,
Burleson, TX (817) 295-2821.

BLASTERS OFF-ROAD CLUB

Dirt Oval and Circuit Off-Road Course.
47 Riel Dr., St. Albert, Alberta. Contacts
Dean M. Simpson, (403) 481-8634, 17319
69th Ave., Edmondton, Alberta, Canada
T5T 3S7.

BUCKLEY SPEEDWAY

37 Douglas Street, Hartford, CT. Every
Sunday April 1st to Nov. 31st Black Top
Oval. For more information call "Ziggy"
or Debbie Kwasnicki (203) 246-4778.

HOBBY HAVEN RACEWAY

1756 First Street, Livermore, CA 94550
AC power, paved parking, computer
scoring, trophy races, trophy dashes, gift
certificates. Coming soon night racing &
oval races. For info (415) 443-5828 M-F

The World Famous
MEGATRAK
 SUPER SPEEDWAY

Presents The



Bud's
 RACING PRODUCTS

August 11th & 12th

*East Coast
 Oval Challenge*

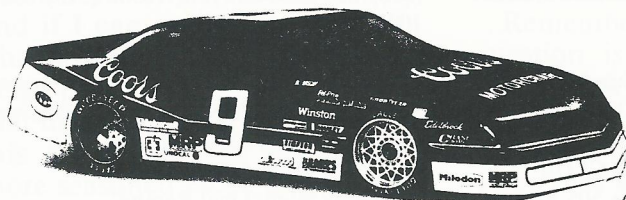

August brings to MEGATRAK the East Coast Oval Challenge sponsored by Cam and Bud's. Bud Bartos and Tate McDaniel are gonna lay it out for you with an event which is like no other. The high powered, world class Bud Bartos will be on hand along with the very flamboyant Tate McDaniel to tip you off on all their speed secrets. This East Coast title is sure to give you the Fame and notoriety you deserve. An information package will be sent to you upon receipt of your entry form and payment. This will include hotel, motel, and other accommodations along with race schedule and format.

Butch, the Atomic Dragster says "Tate, this Bud's for you"

\$ 25.00 MODIFIED PER ENTRY
\$ 30.00 STOCK PER ENTRY *
 * This includes one hand out stock motor
 Entries will be limited - Sorry No Refunds

Make money orders payable to Ed Angiuoli
 Mail entries to:
 MEGATRAK
 c/o Precious Cargo
 P.O. Box 815
 Browns Mills, NJ 08015

Track Information (609) 893-MEGA
 Travelling Directions (609)893-7743
 MEGAFAX: (609) 893-0303

Call anytime for info, directions. If you have any questions MEGATRAK is located on Rt. 70, Mile Marker 31-32, Browns Mills, NJ (Between Rts. 72 & 539)

Name _____ Phone # () _____

Address _____

CLASS	STOCK	MOD	FREQUENCIES		
1/10th Pan	<input type="checkbox"/>	<input type="checkbox"/>	1. _____	2. _____	3. _____
Gearbox Suspension	<input type="checkbox"/>	<input type="checkbox"/>	1. _____	2. _____	3. _____
Monster Trucks	<input type="checkbox"/>	<input type="checkbox"/>	1. _____	2. _____	3. _____

10-6 p.m.

RADIO OPERATED AUTO RACING OF ROCHESTER

110 Anderson Ave., Behind Village Gate
(274 N. Goodman St.)

7:00 p.m. - Monday Pro Night

7:00 p.m. - Tuesday Boy Scout Nite

7:00 p.m. - Wednesday Teen Night

7:00 p.m. - Thursday Indoor Clay

7:00 p.m. - Friday Roar Meetings

7:00 p.m. - Sat. & Sun. Family Days

HOBBY HUT

2665 Park Marina Dr., Redding, CA
96001, (916) 241-3737. 1/10 Off-Road
Racing. Norcal Mini Off-Roaders. Ask
for Kevin Paschke.

USA RACEWAYS

6083 Dixie Highway, Bridgeport, Mich-
igan, (517) 777-7USA.

Every Thursday Oval & Off Road

Every Fri. Indoor Carpet Oval

R.C. BUGGYWORLD & RACEWAY

7511 Hamilton Ave. - RT. 127, MT.
Healthy, OH 45231, 522-0809. Wed-
nesday night off-road and oval on alter-
nating weeks. Also carpet races on
Monday nights 40 x 80 banked oval.

OUTLAW MOTOR SPEEDWAY

7920 Webster, Highland, CA, (714) 864-
1770. Tues. Tamiya Off-Road; Thur. Off-
Road & Dirt Oval; Fri. 1/10 & 1/12
on-road; 1st Sun. Dirt Oval; 2nd Sun. 1/
10 & 1/12 On-Road; 3rd & 4th Sun. Off-
Road.

LITTLES HOBBIES

Monday Nite - 1/10 Trucks

Tuesday Nite - 1/10 Sprint Cars

Wed.-Fri. - Open Practice Available

Sat. - 11 a.m. 2WD 6 yrs. to 16 yrs.

Sun. - 11 a.m. - All Classes Indoor Clay
Oval and Road Track Fast -Stock &
Modified Classes. Bolink AMB Lap
Counter. 111 Main St., Rt. 66, Hebron,
CT 06248, (203) 228-4942.

R/C WORLD & TRACK

New indoor facility for 1/10 off-road and
oval dirt racing. Wed. and Fri. -oval. Sat.
Daytime and Evening off-road. Practice
anytime. Call Glen or Debbie at (303)
789-0838, 2788 S. Federal, Denver, CO
80202.

FAST LANE R/C

On Road Asphalt Track. 21616 Golden
Triangle, Saugus, CA. Call (805) 255-
2404.

RPM R/C RACEWAY

1112 S. 16th, Elwood, IN 46254. Indoor
off-road racing every Sunday at 12:00
noon. For info call (317) 552-7758.

REC. R/C RACEWAY

1/10 scale clay oval track. Racing Sat. -
Oval 10-2:30 - Racing at 3:00 p.m. - Sun-
day - Off-Road 10-2:30 Racing at 3 p.m.
Call Erin Clancy (914) 868-7715. Route
82 to Standfordville, NY 12581.

MADISON AREA RADIO CONTROL CAR ASSOCIATION, INC.

Factory Outlet Mall, Madison, Wiscon-
sin. 1/10 and 1/12 scale carpet racing.
Practice Sat. Afternoon Racing 6 p.m.
Sat. & 7 p.m. Tues. George Jerdee (608)

873-7286.

THE RANCH PIT SHOP

1655 E. Mission Blvd., Pomona, CA
91766 (714) 623-1506. Every Wednesday
night at 6 p.m. Alternating Oval and Off-
Road.

COMPETITION HOBBY

Off-Road racing indoors on dirt. Every
Wednesday night 6:30 - Sunday 12 noon,
Juniors (12 and under) & Novice Satur-
day 12 noon. 8169 S. State St., Midvale,
UT 84047, (801) 562-9452.

CONNECTICUT AUTO RACING TEAM
1/10 Off-Road and Sprint Car Oval. 37
Douglas Street, Hartford, CT 06114, Zig
(203) 246-4778.

HOBBYTOWN

1/4 Mile High Banked Indoor Carpet
Tracks at two of our stores. The Lincoln
track is at our Sutter Place Mall store
located at 5221 S. 48th St., Lincoln, NE
68516 (402) 483-7427. The Omaha track
is located at Rockbrook Village at 11011
Elm Street, Omaha, NE 68144, (402) 391-
5669.

Tues. - 7 p.m. - Lincoln

Wed. - 7 p.m. - Omaha

Sat. - 1 p.m. - Lincoln & Omaha

Sun. - 1 p.m. - Lincoln & Omaha

ROMAC

1/10 and 1/12 on large carpet oval
(Northern Lights Mall) N. Syracuse, NY.
Thursday evenings and Sunday after-
noons. Information call (315) 468-1463
or (315) 468-6544.

COOPER'S RC RACE CENTER

Racing every Sunday 2 p.m.

Open Wed. and Fri. 6 p.m.

Open Sat. & Sun. 12 noon

Oval and Off-Road

Contact Norris, Rt. 4 Box 122B,
Chatham, VA 24531, (804) 724-4182.

VICTORIA HOBBY SHOP

Every Saturday - 2 p.m. - Off-Road;
Every Sunday - 2 p.m. - Ovals.

5211 John Stockbauer, Victoria, TX
77904, (512) 575-3270.

M.H.O.R. R/C RACEWAY

155540 E. Batavia Dr., Aurora, CO
80011, (East on 17th Ave. at Chambers
Rd.). Indoor 1/10 Off-Road Racing on
Wed. & Sat. Practice/Track Time Tues.,
Thur., Fri., Sun. Complete Hobby Shop,
pit area has AC & DC power, a nice
clean handicap accessible racing facili-
ty. For info call Jess Brockman, (303)
343-0151 after 3 p.m. MST. Closed
Monday.

HOBBYTOWN RACEWAY

4915 W. Elm, McHenry, IL 60050, (815)
344-1777. Hobbytown Raceway, 219 W.
Cedar Lake Rd., Round Lake, IL 60073.
Indoor - Dirt 80' straightaways, (312)
546-0707. Oval Racing every Friday 7
p.m.; Off-Road Sunday 10 a.m.

BNS COMPETITION HOBBIES

Route 7, Box 380, Anderson, SC 29624,
(803) 224-8591, Contact Bob Sanford.
Racing and Open Practice Wed. 6:30
p.m., Every Saturday 1:00 p.m. 1/10 Dirt
Oval.

DESERT HOBBIES & RACEWAY

Off-Road racing 1st & 3rd Sundays. Sign
in 10-11:15 a.m. Every Friday nite 7:30
p.m. 25 minutes from San Bernardino.
17210 Main St., Hesperia, CA 92345,
(619) 94858.

TAIT'S HOBBY SHOP

Sat. Off-Road 12 noon, 2WD/4WD
Monster Trucks. Sun. Dirt Oval 12 noon
2WD/4WD Any body style. Mon. Indoor
Oval Carpet 7 p.m. 1/10 & 1/12. Tues.
Truck/Car Pulls 7 p.m. Wed. Outlaw
Dirt Oval 7 p.m. 2WD/4WD Stock cars/
2WD Sprints. Friday. Off-Road 7 p.m.
2WD/4WD Off-Road cars. 3270 Bay Rd.,
Saginaw, MI 48603, (517) 799-3900.

J.G.S.

Wisconsin's finest off-road race track.
Perfectly groomed 100 ft. straightaway,
computer scoring, drivers stand, starting
lights. Racing every other Sunday 1 p.m.
Menomonee Falls, WI (414) 255-2040.

TRACKSIDE RACEWAY

Dirt Oval Racing every Thursday night 6
p.m. Fully stocked hobby shop, com-
puter scoring, lights, bleachers, con-
cessions. Menomonee Falls, WI (414)
255-2040.

WAGONHILL HOBBIES

Indoor 1/10 & 1/12 on-road racing every
Friday night. Outdoor Off-Road every
Saturday Night. 225 S. Board St, Grove
City, PA, (412) 458-4711.

DIXIE R/C HOBBY SHOP

Every weekend Sat. & Sun. The races
will alternate between oval and motoc-
ross starting May 14 with oval and May
15 with motocross. Dixie R/C Hobby
Shop, P. O. Box 135, Ramseur, NC
27316, after 6 p.m. (919) 824-2770.

BREMEN RACEWAY

Clay Oval Track 60 x 100 ft. Under roof,
lighted Friday nights 7 p.m. May thru
Sept. Call for information (219) 546-
3807. Bremen Hobbies, 308 N. Bowen,
Bremen, IN 46506.

WEST TEXAS R/C RACEWAY

3477 Lee Blvd. - Racing every Sunday. 1/
10 scale off-road and oval dirt. Mailing
address: 301 Edith Dr., El Paso, TX
79915. For more information call Hector
(915) 772-1382.

JIM'S R/C SPECIALTIES

3107 S.W. Van Buren. Topeka, KS 66611
(913) 273-4070. Racing off-road every
Sunday 12 noon to 5 p.m. Oval racing
every Saturday night 6 p.m.

EAGLE HOBBY CENTER & RACEWAY

Every Saturday night at 7:30 p.m. 1/12 4
cell stock and modified. 1/10 6 cell stock
on-road, call for body style. Eagle
Hobby Center & Raceway, 3601 Shep-
herd, Balch Springs, TX 75180, (214) 557-
5290.

ACTION SPEEDWAY

Indian River's Facility

1/10 scale half mile clay oval & off-road.
Two story covered drivers' stand, large
pit area close to track, ample parking,
classes for young and old, beginner's to
expert's, and truck pulls. Coming soon -

1/10 scale super speedway and road course, night racing, full electric, and concessions. For further information call Trace or Chip Button (407) 231-9410 or Doug Upton (407) 569-8793.

THE INSIDE TRACK

Every Wednesday - 7 p.m. and Saturday 6 p.m. Classes: 2WD Stock and Modified, 4WD Stock and Modified and Monster Trucks. For more information call (312) 898-5649. 725 Hill Avenue, Aurora, IL 60505.

ABC R/C

Clay track racing every Saturday 1 p.m. Truck pulls every Tuesday 6:30 p.m. Complete R/C headquarters, 1441B E. Main Street, Waukesha, WI 53186, (414) 542-1245.

TC'S R/C'S

Inside and outside race track and RC shop, 1537 Freeport Road, Natrona Heights, PA 15065, call 226-8802.

BROCKTON INTERNATIONAL SPEEDWAY

Monday night 1/10 & 1/12 oval racing 5:30 to 7:30 Practice. Races start 7:30 p.m. 1217 Main st, Brockton, MA. For more information call Ruben (508) 588-9355.

SONOMA COUNTY RACEWAY

806 Brookwood Avenue, P. O. Box 9565, Santa Rosa, CA 95405 -1/10 Dirt Oval, 1/10 Off-Road, 1/10 & 1/12 Asphalt. Mark White (707) 571-7565, Schedule info (707) 571-8044, Competition Products (707) 571-8048.

ALL IN 1 RACEWAY

5612 S. 108th St. Hales Corners, WI. 1/10 scale indoor dirt track. High speed semi-oval and true off-road courses. Practice Tues, Thrus., and Fri. 6 - 9 p.m. Racing Wednesday nights at 6 p.m., Sat. & Sun. at 1 p.m. For more information call (414) 425-4060.

THE SQUARE ROUNDHOUSE SPEEDWAY

Saturdays - 3 Events per month -Off-Road, Monster Truck Pulls and Oval Race, Oval dirt track and Off-road track. 1468 Lander Avenue, Turlock, CA 95380, (209) 668-4454, Ask for Harold Lindquist.

COASTAL BEND SANDBLASTERS R/C CAR CLUB

Races first thru 3rd Sundays, 2 p.m. start. Bill Witt Park, Yorktown Road, Corpus Christi, TX, Call Pete Broadway (512) 992-4448.

CAJON R/C SPEEDWAY

1875 Joe Crosson, El Cajon, CA 92020. Fastest paved oval & road course in CA. 1/10 & 1/12 scale. Please call for off-road dates. Hot Line (619) 449-0788/Track info 449-9948.

RADIO CONTROLLED HOBBIES & RACEWAY

Indoor Off-Road racing every Tuesday & Thursday evening beginning at 7 p.m. and Saturdays at 5 p.m. Open 7 days a week. 2011 Placentia Ave., Costa Mesa, CA 92627. For more info call (714) 631-

1555.

R/C RACEWAYS

1/10 indoor dirt oval. 100' straightaways. Wed. 6 p.m. oval. Friday 6:30 p.m. oval. Sunday 12 noon oval or off-road. For more information call (219) 747-6414. 2710 Nuttman, Ft. Wayne, IN 46804.

R/C PERFORMANCE CENTER

Indoor high banked carpet oval. 170' x 90' off-road dirt indoor track. Racing 4 Days a week; Tues., Thurs., Sat. & Sun. Open 10 a.m. - 10 p.m. 7 days a week. 4 Manley Street, West Bridgewater, MA 02379. Ask for John (508) 588-9666.

PARLOR HOBBIES

Short Track Stock Car Racing on Road Courses. 1/10 on Asphalt - Full bodies - Grand National or ASA bodies preferred. Truck class with 1/12 on-1/12 off-road & hill climb. June 10 - June 24 - July 1 - July 8 - July 15 - July 29 - Aug. 5 - Aug. 12 - Aug. 19 - Aug. 26 - Sept. 16 - Sept. 23 - Sept. 30 - Oct. 7 - Oct. 14 - Oct. 28 - Nov. 4 - Nov. 11 - Nov. 18. Rabbit Lane & 34 Broad St., Matawan, NJ 566-3158.

R/C SPEED CENTER

R/C ADDICTION

2810 N. Pacific Hwy., Medford, OR 97501, Call Gene or Betty Skelton, (503) 779-8298. 1/10 and 1/12 scale, banked dirt oval racing, dirt off-road racing, sled pulls, mudbog. Racing every week, year around.

BROTHER-IN-LAWS R/C RACING

1/10 scale dirt oval. Racing every Sunday. Signups 10 a.m. Open Practice 12-6 Tues. - Sat. pit tables, 110 volt power. Call Bob (619) 949-5252. 16175 Main Street, Hesperia, CA.

CORCAR - COLUMBUS, OHIO

1/10 off-road racing May thru Sept. every Sunday. Signups start at 10:30 a.m. Excellent dirt track, computer scoring and picnic area. For information call Ray Williams (614) 890-2983.

MACHESNEY PARK RACEWAY

1220 Shappert Dr., Machesney Park, IL, (815) 282-1311. Large asphalt oval, racing every Saturday and alternating Sundays, April thru October.

CENTRAL MARYLAND ELECTRIC RACING CLUB

(CMERC) Community R/C Speedway Middletown Park, Middletown, Maryland. 100' x 50' dirt oval, 14' wide lanes, 2' banked turns, No electricity available. Every Saturday. Contact John Mauchamer, (301) 698-9545.

SCHENECTADY R/C SPEEDWAY

Indoor Oval Carpet Racing. 1/10 & 1/12 and Monster Trucks. 955 State St., Schenectady, NY, (518) 370-3747.

THE COCKEYSVILLE ASTRODOME

C.A.R. Cockeysville Astrodome Racers, Inc., 10854 York Rd. (Rear) Cockeysville, MD, (301) 666-1098. High Bank Oval racing on concrete (indoors). Benches, Power, Grandstands. 7 p.m. Mon. - Open Practice; 7 p.m. Tues. - Rookie & Stock Practice; 7 p.m. Wed. - Computer

Organized Racing; 7 p.m. Thurs. - Modified & Ultra-lite Practice; 7 p.m. Fri. - Trucks & Buggies Practice; 5 p.m. Sat. - Computer Organized Racing; 1 p.m. Sun. - Computer Organized Racing. Art LaPole (301) 889-2070.

BOB'S R/C SUPPLY & RACEWAY

Indoor Carpet Racing! Tues. 1/10 Oval; Fri. 1/12 Road Course; Sat. Monster Trucks. Stock & Modified. Snack bar. Call Bob, Nancy or Kevin (319) 232-2235, 935 Sheerer Ave., Waterloo, IA 50701.

EBERSOLE HOBBY & R/C RACEWAY

Off-Road and Oval. Races Wed., Thrus., Sat., and alternate Sun. 11417 W. Highway 54, Wichita, KS 67209. Len Ebersole, (316) 722-8888.

METRO-FAST RACEWAY & HOBBIES

125' x 48' indoor carpet track, pitting for 140+, power, hobby shop, video entertainment, food bar. Oval - Fri., Kid's racing every Sat. morn and alternate Sun. on on-road & off-road. 950 W. Irving Park Rd., Hanover Park, IL 60103, (312) 213-3977.

MID-CAROLINA R/C SUPER SPEEDWAY

The speedway is located on Flint Hill Rd, Off 1-77/Carowinds exit, So. of Charlotte, NC. 1/10 & 1/12 High-Speed Banked Quad-Oval and Road Course. 385 ft. plus 26 degrees banking in turns concrete track. Fred Penland (704) 373-2535 7:30 a.m. to 4:30 p.m.

BROWNIE'S HOBBIES

Off-Road Dirt Track, hobby shop. Wed. eves and Sat. afternoons for practice. Racing - Fri. eves. 4WD & 2WD. Track open April -November. 124 Bennett St., Staten Island, NY 10302, (718) 727-2194.

ROADRUNNER R/C CENTRAL

5620 Bellaire, Houston, TX 77081, (713) 661-7574. 1/12 Carpet Oval or Road Course Thurs. Nite. 1/10 Carpet Oval Tues. & Fri. nite & Sun. pm.

ROADRUNNER R/C NORTH

12760 Veterans Memorial, Houston, TX 77014, (713) 537-7758. 1/10 Dirt Oval Wed, Fri. nite. 1/10 Dirt Off-Road Sat. & Sun.

ROADRUNNER R/C SOUTH

12902 Player, Houston, TX 77014, (713) 728-2277. 1/10 Indoor Dirt Off-Road Wed., Fri., & Sat.

NORTHERN MINI-RACERS

NMR Raceway, P. O. Box 415, 3524 E. Burdick, Minot, North Dakota 58701. 1st & 3rd Sun. 1/10, 6 cell, NASCAR bodies, oval racing on carpet. Roger Lee, (701) 839-4731, 839-5294; Pat McWethy, (701) 839-8868, 852-6254.

ASHEVILLE HOBBY SPEEDWAY

Racing Wed. & Sat. - 7:30. 1/10 & 1/12 Asphalt Oval -Indoors. Hwy. 25, Naples, NC 28760, (704) 684-9814. Jack or Sharon Murdock.

HOBBY CENTER

High banked carpet oval track. Racing Fri. -7:30 p.m. 1/10 NASCAR, trucks, 2WD gearbox hot rod, 4WD wedge

IF YOU'RE REALLY SERIOUS ABOUT RACING,



THINK BIG.

RC10-2 TIMES WORLD CHAMPION 1985-1987, 1989-1991



AT TEAM ASSOCIATED WE ALWAYS THINK BIG. AND WIN BIG.

Like *World Championships*. Team Associated cars and drivers have won an unparalleled **8**, including titles in 1:12, 1:10 and 1:8 scale competition. No other R/C car manufacturer's team has won more than two.

Associated cars win more than just the biggest races, too. Readers of *Radio Control Car Action* magazine voted the RC10 the 1988 R/C Car of the Year, and by a resounding margin of six to one over the second place car! Thank you very much, readers.



Radio Control Car Action also held a shootout between the RC10 and the next most popular car, and the RC10 came out a winner again!

And at the Reedy Race of Champions (called a re-run of the World Championships because all the drivers from *Europe*, *Japan*, and the *USA* who made the A Main at the World Championships were present), the RC10 finished first and second.

Racers, readers and dealers all agree. Performance, reliability and readily available spares make the RC10 a big Number One.

Whoops, gotta go now. I want to watch *World Champion Jammin' Jay Halsey* take a victory lap with his RC10.



Actual, custom-detailed RC10, with custom wheels.



Associated Electrics
3585 Cadillac Avenue/Costa Mesa, CA 92626

bodies. 1/12 scale. Any body ROAR stock motors all classes. Open practice during store hours. (502) 683-7611. 1233 Sweeney St., Owensboro, KY 42301.

R/C MOTORPLEX & HOBBY

Outside Tracks: One of Midwest's largest paved oval (160 x 115) with paved infield road course. Indoor Tracks: Dirt off-road & dirt oval. Carpet road course & oval. 1/12, 1/10 & 1/8. Snack bar, game room R/C hobby shop. 303 Herbert Rd., McHenry, IL 60050. (815) 385-1240. Bob Oaks or Jim Bostrom.

SACRAMENTO MINI-WHEELS RACEWAY

Indoor racing with 1/10 & 1/12 scale. Two tracks with off-road, dirt oval, and on-road. The on-road track is etched concrete. Racing Wednesday (off-road). Fri. (on-road). Every other Sat. (dirt oval). Sun. (off-road). 8711 Elder Creek Rd., Sacramento, CA 95826. Paul or Marge Schiager (916) 383-4011.

RAPID TRANSIT RACEWAY

2104 Broadway, Schenectady, NY 12306, (518) 372-0777. Summer Store Hours: Mon. - Fri. 4 p.m. - 10 p.m., Sat. 11 a.m. - 5 p.m.. Race Schedule: Mon, Tues. & Sat. Open for Practice. Wed. 7:30 p.m. Stock & Mod. Thurs. 7:30 p.m. Sprint Car. Fri. 7:30 p.m. Sportsman & Open Class.

NORTHERN ALBERTA SCALE

CAR AUTO RACING

1/12 and 1/10 On-Road Racing. 1/12, 4 cell indoors on carpet during winter. 1/10, 6-cell outdoors during summer. Dean Simpson (403) 481-8634, 17319 69th Ave., Edmonton, Alberta, Canada T5T-3S7.

HOBBY CORNER RACEWAY

Sun. - alternating oval & off-road 1 p.m. Tues. - oval racing 7 p.m. Large indoor dirt oval track with 4 foot banks. 2195 E. Garfield, Decatur, IL 62526 (217) 429-4477.

PHILLY RADIO CONTROLLED RACERS R/C CAR CLUB

Announcing the opening of a paved race track for R/C 1/10 on-road. ROAR rules. Sun., April - November. 11 a.m.. 7790 Dungan Rd., N. E. Philadelphia. Jon (215) 224-4822 or Bernie (215) 831-1835.

ARVIN'S HOBBY CENTRE

1403 E. Spring St., New Albany, IN 47150, (812) 945-3745. We have a 2,600 sq. ft. carpet track which has moveable rails so that we can change the layout from oval to off-road. We run offroad and on-road cars on Saturday, Sunday, Wednesday nights.

ISLAND HOBBIES & RACEWAY

Mon.: 2WD Monster Trucks - Stock, Monster Trucks 6-cell Mod.; Tuesday 1/10 Off-Road Stock, 1/10 Sprint Cars - Open; Wed. 1/10 On-Road, Stock NASCAR bodies, On-Road 6-cell Mod. GTP bodies; Thurs. 4WD Trucks - Open, 4WD Cars - Open, 1/12 On-Road Stock 6-cell. All racing starts at 7 p.m. Open practice Sat. & Sun. Contact Dave at (516) 234-7428.

D & T HOBBIES

Two tracks, off-road & high speed concrete oval. 1/10 & 1/12 Wed., Fri., Sat., and Sun. For specific, please call (219) 674-8533. 55575 Ash Rd., Osceola, IN 46561.

TEXAS R/C RACEWAY

Home of the Plano Outlaws

Tues. and Sat. - 1/10 On-Road; Fri. NAS-CAR nite; Sun. 1/12 On-Road. 75 Central Espressway at 15th St. Exit 29, Palisades Square Shopping Center, Plano, Texas. Call Jim (214) 517-7485 or Dean (214) 519-0324.

RACEWAY HOBBIES

Wed. 7 p.m. - 2WD & 4WD Off-Road; Sat. 1 p.m. - Off-Road & Oval. Lexington Shoppes, 6845 So. U.S. A, Port St. Lucie, FL 34952. (407) 468-4338.

TEAM R & R, INC.

Westminster, Maryland 21157. Indoor oval carpet racing, 1/10 & 1/12 scale. Racing every Sunday. For more info, phone (301) 848-2144 or (301) 876-2983.

SUMMIT SPEEDWAY

Indoor Dirt Oval - Every Friday Night 7 p.m. Sundays indoor or outdoor (weather permitting) off-road or oval at noon. Call (219) 489-RACE (7223). 1706 W. Till Rd., Fort Wayne, IN 46818.

K & M R/C SPEEDWAY & HOBBIES

735 Canal St., Stamford, CT 06902, (203) 967-7255. One of New England's Largest Indoor Tracks. Weekly Hours Mon.-Fri. 4 p.m.-10 p.m.; Sat. & Sun 12 p.m.-10 p.m. 7,000 sq. ft. complex, ample pit area with power, 110' x 35 sq. ft. track anti-static carpet, fully stocked hobby shop. Organized racing held on a weekly basis. Call for details.

ALCAR INTER. R/C RACEWAY

Off-Road Fri. nights, 1/12 & 1/10 carpet Sundays, Closed Mondays. Hobby shop & snack bar. 33501-A Lake Rd., Avon Lake, OH 44012, (216) 933-6017.

MARYLAND R/C CLUB

1/10 & 1/12 Scale Racing

Indoor Carpet racing

Contact Toy World R/C, (301) 424-0430.

R.C.A.R. of TULSA

Indoor Racing, 10404 E. 55th Place, Unit A, Tulsa, OK. March 3, 10, 17. Track Opens 6 p.m. Qualifying begins 7 p.m. For more info call Dave Cole (918) 745-9898.

HOBBIES ETC. RACEWAY

Medford High School, Winthrop St., Medford, MA. Every Sunday. Doors open at 12 noon. Racing at 1 p.m. Indoor on-road carpet course for 1/10 and 1/12 scale. Computer lap counting, trophy and gift certificate awards. Ample parking, AC power, technical aid, hobby shop and concession stand on sight. For more info call (617) 389-3331.

AMERICAN ANGLER TACKLE & R/C HOBBY CENTER'S "AA RACEWAY"

1617 Toomey Rd., Austin, TX 78704, (512) 474-8277. Two dirt tracks, Oval & Off-Road. Races every Sunday, 1 p.m. Tracks Alternated Races Every Saturday

11 a.m. Oval. Hobby shop on site.

REMOTE HOBBY'S INDOOR RACING
Shop (803) 736-9446, Track (803) 699-0528. 9005 C Two Notch Rd., Columbia, SC 29223. Fri. nites - Oval 1/10 Pan/Trans. Sat. nites - Road Course 1/10 Pan/Trans/Trucks. Pits for 40+, Parts, Power and Refreshments.

MacKAY RACEWAYS

1/10 Electric Off-Road Sundays. 1044 West 14th Street, North Vancouver, BC Canada. 150' straights/5'banks/moguls & jumps. Operated by the Western Canada R/C Club. For info call Dana Shaw (604) 980-4504.

ANTIOCH RACEWAY

1/10 dirt oval racing every Fri. 7 p.m. / 10 off-road every Wed. 7 p.m. All Classes. Sat. & Sun. 1/10 dirt oval and off-road 10:30 a.m. Also night racing. Pit Tables, Power, open 7 days a week. 5631 Lone Tree Way, Antioch, CA 94509. Call (415) 754-5700 Jack Hanson.

CLEVELAND RADIO RACEWAY

3209 Lorain Avenue

Cleveland, OH 44113

For more info contact Troy Singer (Owner) (216) 741-1649 or Rick Moore (Race Coordinator) (216) 255-5429 Fri. 7-Midnight Oval or Off-Road; Sat. Noon - 6 p.m. Practice; Sun. 10 a.m. - 6 p.m. Oval or Off-Road. Classes: 2WD Stock & Modified; 4WD Modified & Monster Trucks.

SWEET UNION R/C RACEWAY

1/10 Dirt Oval & Off-Road. 388D Quarry Rd., Monroe, NC 28110. 300' 4 Turn Oval, 520' 19 Turn Off-Road (Shortest Line Measurement). "TrackMate" Lap Counting & MGT System. Racing Sat. & Sun. 1st & 3rd Weekends. Covered Driver's Stand, Trophies & Door Prizes Each Race Day. For more info Call (704) 289-3621.

NORTHSTAR RACEWAY

Featuring Minnesota's first indoor & outdoor clay oval and off-road surfaces. Fully stocked, specialized hobby shop. 10751 University Ave., Blaine, MN 55433, (612) 757-0374. Tues. - 7 p.m. off-road; Thur. - 7 p.m. oval racing; Sat. - 11 a.m. off-road racing. Send S.A.S.E. or call for complete schedule.

SIDEWAYS CITY

22,000 sq. ft. Building, racing every Tues. & Fri. nite and Sun. afternoon. Hobby shop, hot food concession, video game room, and kiddy land. The track is a super speedway cement oval. Dirt track open May thru September. Call (616) 792-2004 for further info. Located in Wayland, MI. Take US 131 to the Wayland Exit, turn East to light, turn North 1/12 mile.

RIVER CITIES R/C RACEWAY

Ashland, Kentucky 41101

Racing at 5:30 Saturday evenings under a light area. Radio impound, concession booth, IBM Computer, Brimstar Management System, and AMB Lap Counter and P/A system. The track is a semi-

hard dirt oval, 90' straight with 12' lanes and 60' across. Corners are banked approximately 15 degrees with 14' lanes, ample room for passing. Call Randy Aust (606) 836-4273 or Jason Graham (606) 836-2613.

SMR/CRC

First Sunday of Each Month at G.I.A. 1660 Stewart Street, Santa Monica, CA. Sign-up 8:30 a.m., Practice 9:15 a.m., Qualifying 10 a.m. For more information call Glenn Williams (213) 734-7888, Chris Chan (213) 393-3735, Tom Wong (213) 821-5472.

TARCAR - TOLEDO AREA

New black clay tri-oval. 1/10 oval and off-road. Sunday late April thru Mid-October. For more info call Dave Scanes. (419) 893-1916.

ACTION R/C RACEWAY

New Hampshire's finest indoor carpet high banked oval. AMB scoring, hobby shop, snack bar, rentals. 1/10 scale all classes including monster truck pulling. Family Fun Hobbies, 201 Washington St., Claremont, NH. Convenient to I-91 & I-89. 2 Hours from Boston & Hartford. Open 7 Days. (603) 543-1022.

WESTSIDE HOBBIES

Asphalt racing every Sunday. Sign-ups start at 9 a.m. Races start at 11 a.m. Alternating oval & road course. 1/12 & 1/10 on-road, 1/10 off-road cars and trucks, all classes. Full line hobby shop. For further info call Tom, Mark or Tim Minter. (915) 585-1864. 7214-A N. Mesa, El Paso, TX 79912.

R.R.O.L.

1/12 carpet racing Tuesdays, 1/10 carpet racing Wednesdays. Sept. to May, Asphalt & Off-Road in Summer. Remote Racers of London, P. O. Box 7241 Stn. E. London, Ontario, N5Y 4J0 Canada. Dan Engelbreth (519) 668-0427.

R.C. CITY RACEWAY & HOBBIES

Off-road racing every Tues., Fri., Sun., Oval racing every Sat./Practice time and rentals available. Call for more info. (408) 262-3188. 1453 N. Milpitas Blvd., Milpitas, CA.

EAST LYME R/C KAR KLUB

Every Sunday starting on May 20 thru September. Practice 9 a.m. Registration 10 a.m. Racing at 11 a.m. Located at Society Road, East Lyme, CT (Behind the Junior High School). For racing info call Paul Johnson, 739-4070 eves or weekends.

ALTERNATIVE

RACING ASSOCIATION

1/10 and 1/12 on-road racing. Two large tracks, indoors 75' x 48' gray ozite carpet track, outdoors 140' x 64' permanent asphalt track. AMB lapcounting. Classes for beginners to experts. For more infor-

matio call: Neal Everhart (216) 484-2587. 2600 17th, SE, Canton, OH 4730.

— 1/12 SCALE —

FLORIDA STATE SERIES

July 14 & 15 - Rockledge
Sept. 15 & 16 - Orlando
October 13 & 14 - Pinellas Park
November 10 & 11 - Naples

GLASS CITY RADIO CONTROL

Racing 1/10 & 1/12. Clayton White (1/12) (419) 882-2518 or Mike Marshall (1/10) (313) 241-5321.

S.T.A.R.C.

Wed. Night - S.T.A.R.C. Club Series. Rockton, Ontario, Canada. Sam Burke (519) 621-5424.

TEAM RACE R/C CAR CLUB

Fri. 6:30 p.m. indoor track, 505 Spring Ridge Rd., Clinton, MS, (601) 924-0722.

NORTHERN MINI-RACERS

NMR Raceway, P. O. Box 415, 3524 East Burdick, Minot, ND 58701. 1st & 3rd Sat., 1/12, 4-cell, Can-Am/GTP bodies, road racing on carpet. Roger Lee, (701) 839-4731 or 839-5294. Pat McWethy, (701) 839-8868 or 852-6254.

KOUNTRY KLIN HOBBY

1/12 scale small indoor carpet track & hobby store. Box 247, 324 Railroad Ave., N. Mohall, ND 58761, (701) 756-6307.

USA RACEWAYS

6083 Dixie Highway, Bridgeport, Michigan 48722, (517) 777-7USA
Tue. Nite On-Road; Sat. Nite On-Road; Every Other Sat. Eve. Stock On-Road

THE RANCH PIT SHOP

1655 E. Mission Blvd., Pomona, CA 91766, (714) 623-1506. Every 4th Sun. 1/12 & 1/10 On-Road Combined Program.

OMAHA NEBRASKA RADIO OPERATED AUTO DRIVERS

Very active racing schedule. Carpet and Pavement racing in 1/10 and 1/12 scales. All classes - Oval and road course. ROAR rules. (402) 331-2907.

S.O.R.C.R.C.C.

Southern Ontario Radio Control Race Car Club in Toronto, Ontario, Canada. Racing Alternating Sun. nites October - April. 6 p.m. to 10 p.m. Scott Reynolds 298-4941 or Gary Joi 421-9061.

CENTRAL MARYLAND ELECTRIC RACING CLUB

COMMUNITY R/C SPEEDWAY

Middletown Park, Middletown, Maryland. 100' x 50' dirt oval, 14' wide lanes, 2' banked turns, drivers stand, no electricity available, open to the public. Mark Coats (301) 694-7420.

HOBBIES PLUS & R/C RACEWAY

1/10 & 1/12 scale indoor carpet racing. Tri-Oval & on-road, 60+ pit areas w/ electric. hobby shop. 7 days. open prac-

tice. Also Sun. A.M. 1/10 off-road dirt (150 x 70) and 1/8 gas off-road. 650 Amherst Street, Nashua, NH 03063, (603) 882-9200.

CARPETBURNERS R/C CLUB

436 East Main St. (Rear), Danville, IL 61832. (217) 442-7466.

CAPITOL DISTRICT R/C OUTLAWS

4 Cell Carpet Cars. NASCAR bodies, Oval and Road Course. Every Friday Night at 7:30 p.m. October to the End of April. For further info contact Capitol District R/C Outlaws, 223 Fourth St., Scotta, NY 12302, or Sam Roberts (518) 374-3801.

JAY'S R/C

5018 14th Street West, Bradenton, FL 34702, (813) 756-6393, 758-2565, 746-8649. AMB Computerized lap counting. Indoor carpet oval and road course.

— SPECIAL EVENTS —

ROAR NATIONALS SUPER TOUR

1/10 & 1/12 On-Road

June 14-24 - Plano, TX

Dean Densmore - (214) 519-0324

1/10 Off-Road

July 19-29 - Livermore, CA

Tom Welding, Jr. - (415) 443-5828

1/8 Gas

Aug. 30-Sept. 3 - Dallas, TX

Joe Sullivan (214) 238-0929

NORRCA NATIONALS

1/10 Off-Road

July 6-8 - Dallas, TX

Norm's R/C Hobbies

(214) 357-3453 or

(714) 981-9641

Pavement Road Course

June 1-3rd - Bakersfield, CA

Racers Haven

(805) 835-0441 or

(714) 981-9641

SPEEDWORKS 1990 SPORTSMAN TRIAD CUP SERIES

SEMROCC

July 6, 7, & 8

Sterling Heights, MI

(313) 644-0669

RANCH PIT SHOP

October 5, 6 & 7

Pomona, CA

(714) 623-1506



GET SERIOUS ABOUT YOUR RACING FUTURE

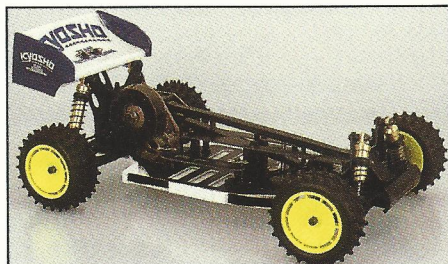

Graphite top and bottom chassis plates offer high strength with low weight. The Lazer ZX layout means quick maintenance.

Kyosho has lifted 4WD technology and design to a new level with the introduction of **Lazer ZX**. Starting with a clean sheet of paper, along with the experience gathered in the design and refinement of the Optima Mid series of cars, Kyosho has given today's off-road racer a new weapon for the racing wars.

Redesigned. Not rehashed.

Kyosho has engineered many significant improvements into the Lazer ZX. A new twin belt, low friction drive system powers front and rear differentials, with new universal swing shafts transferring power to the wheels.

At the heart of the drive train is a center differential on the mainshaft, allowing adjustable torque split for any track condition. The center diff also includes one-way bearings for the front drive system. Of course, a car of this caliber features full ball bearings as standard.

Kyosho has made a vast improvement in suspension geometry with the Lazer ZX. Utilizing extra long suspension arms with pick-up points well inboard, the Lazer's suspension tames the wildest of racing conditions, while Kyosho's famous Gold Shocks help dampen the roughest terrain. The suspension is also totally adjustable to any desirable geometry.

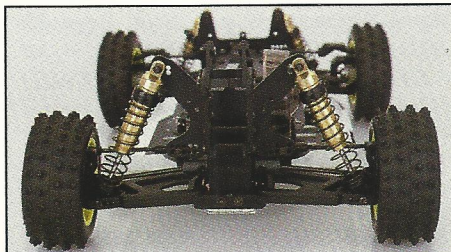

Lazer features improved double wishbone suspension arms. Upper suspension links allow front and rear camber adjustment.

The Right Parts. The First Time.

The Lazer ZX includes a graphite chassis and top plate for low weight and high strength, and accepts either saddle or stick-type batteries.

Unlike other "high performance" cars that include black fiberglass chassis, Kyosho includes the right parts the first time.

Kyosho also includes many features to help today's racer spend more time racing and less time in the pits. For example, the Lazer ZX body comes complete with an undertray to keep out dirt and dust. And an adjustable wing mount is an integral part of the chassis (no more bending music wire to adjust wing angle!) For easy maintenance, both differentials can be accessed by the removal of a few screws.

Today's racer demands serious equipment. Get the new Lazer ZX from Kyosho. And get serious about your racing future.

KYOSHO® **LAZER ZX**™

DISTRIBUTED TO LEADING RETAILERS
NATIONWIDE EXCLUSIVELY THROUGH
GREAT PLANES™
MODEL DISTRIBUTORS COMPANY
P.O. BOX 4021, CHAMPAIGN, IL 61824-4021

Send to our address for your **FREE** copy of
Kyosho's Mini Catalog from Great Planes.

NEW PRODUCTS

RC10 On-Road Conversion Kit - #AC0401, \$99.95. This kit transforms your off-road RC10 into an awesome mid engine on-road/oval race car. The chassis uses the same proven beam front axle design used on the Hyper 10 on-road car. Prototype cars have broken track records across the country. Kit features easy set-up and super predictable handling. Uses stick battery format instead of saddle packs. Kit re-aligns rear end geometry toe-in for superior on-road performance. Hyperdrive, 3210 Howard Nickell Rd., Fayetteville, Arkansas, (501) 444-8200.

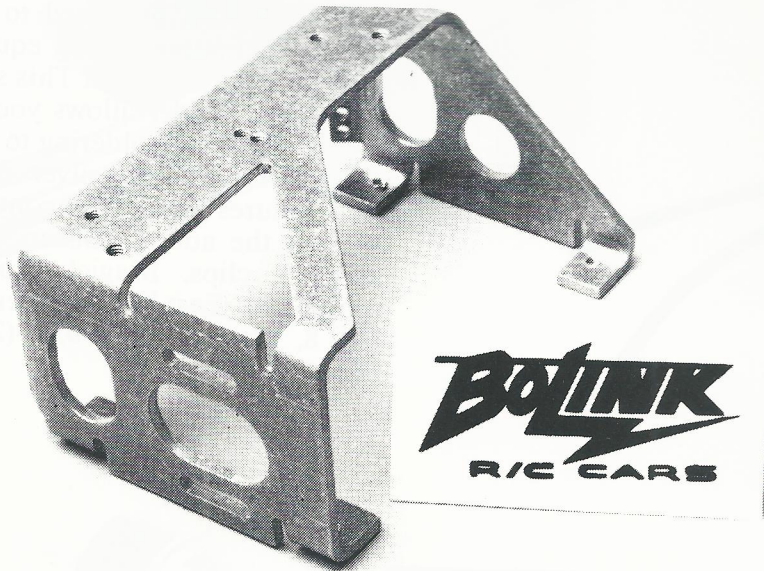
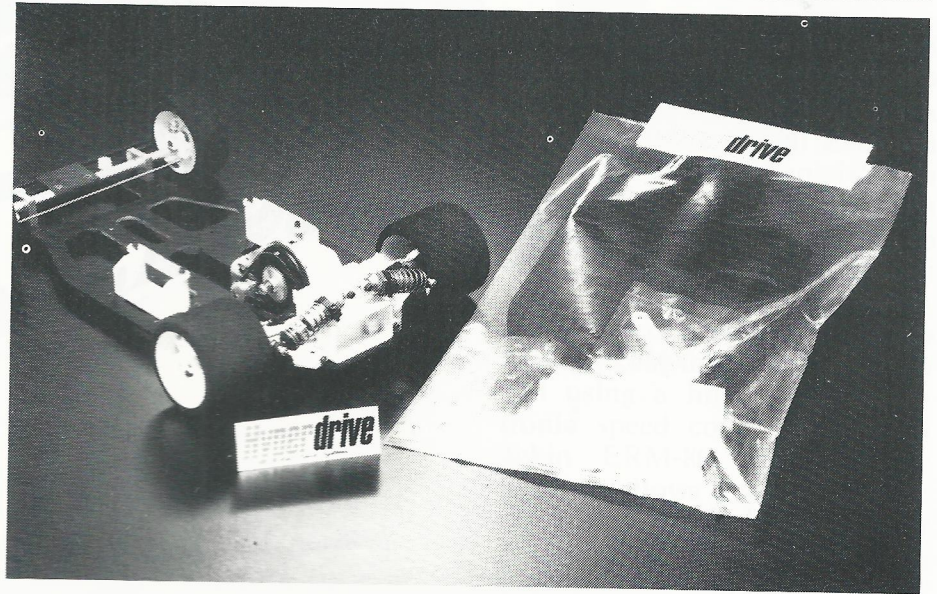

BL-5194 - Aluma-Lite Rear Pod \$37.95. BoLink's new Aluma-Lite Rear Pod for our 1/10 scale cars replaces the motor mount, left axle carrier and rear brace. It's made from aerospace aluminum and is stronger and lighter. It comes with axle height adjusters and screws to mount it to the stock T-plate. Complete information on all BoLink products is available by sending \$3.00 for the latest catalog/price sheet, and a FREE "He Who Dies With The Most Toys Wins!" bumper sticker. Write to: BoLink R/C Cars, Inc., 420 Hosea Road, Lawrenceville, GA 30245.

RC10L - Shock Performance Kit - This kit provides more consistent damping of the rear suspension and thus improves the overall handling of the car. Included in the kit is a special rubber bladder and a genuine RC10L shock cap (precision machined to accept the bladder) and detailed instructions telling how to set-up the RC10L shock for best results. Part #050. RC Performance Specialties, 18312 Gifford St., Fountain Valley, CA 92708, Phone (714) 962-6928, FAX (714) 962-4089.

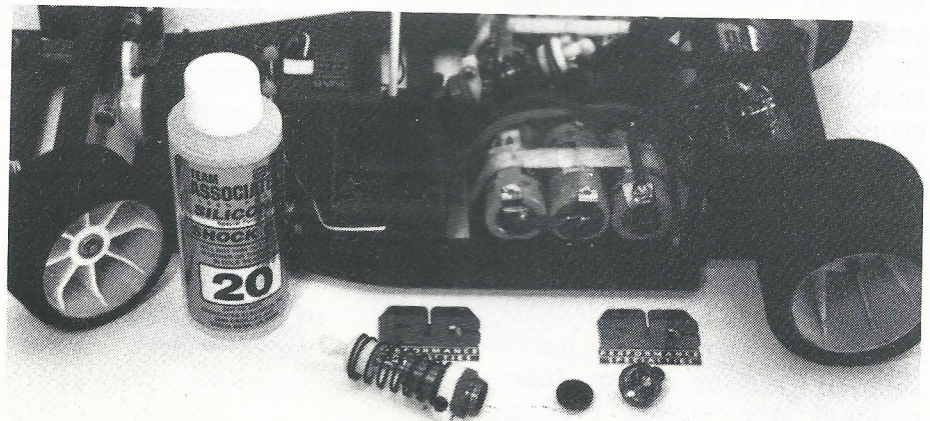

NEW! 1/10 Scale TOJ Can Am Car Body: Part No. 6178 - \$18.00. Associated's new TOJ faithfully recreates the authentic detail of the original winner, including smooth, aerodynamic lines designed to hug the ground and cross the finish line in first place. Associated Electrics, Inc., 3585 Cadillac Avenue, Costa Mesa, CA 92626, (714) 850-9342.

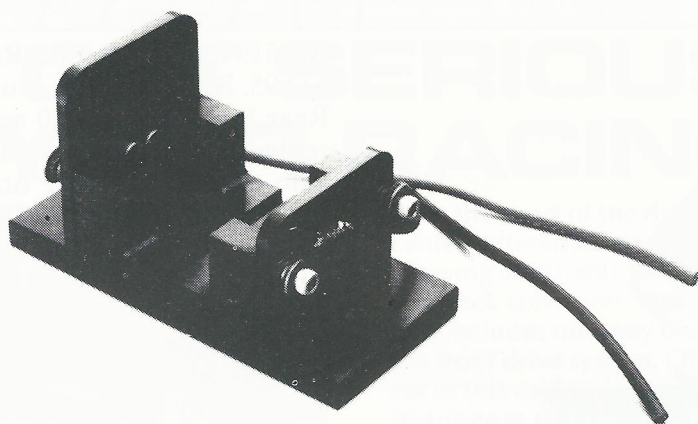
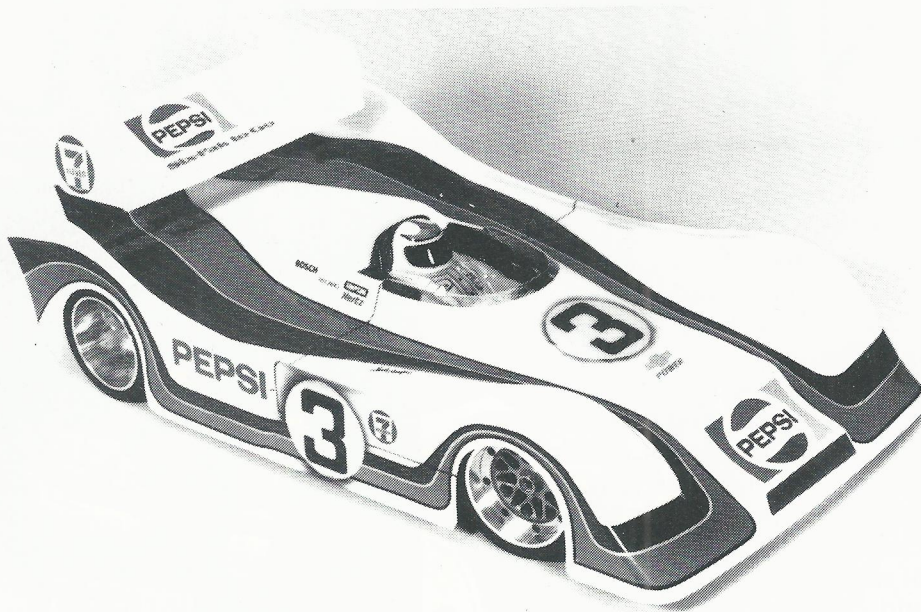

MM300 "Single Cell Battery Holder" \$69.50. Designed to be used with battery testing equipment like the Cellmate. This spring loaded holder allows you to test cells without soldering to the cells themselves. Two silver contacts assures maximum contact, without the added resistance of alligator clips. Magic! Motorsports, 1901 East Linden Avenue, No. 8, Linden, NJ 07036, (201) 862-1705.

New Parma Cyclone Dish Wheels fit any 1/10 scale on-road car. These hot wheels are lightweight and feature an "Aerodesign" for low drag. The Parma Cyclone Dish Wheels are available in neon yellow or glowing pink. Allen head bolts are available separately. #17038 Bolts for dish wheels, 8/\$1.50; #17039 Yel. FR. Pr/\$6.00; #17040 Pink FR. Pr/\$6.00; #17139 Yel. RR. Pr/\$6.00; #17140 Pink RR. Pr/\$6.00. Ask for them at your local hobby shop or raceway. Parma International, Inc., 13927 Progress Parkway, North Royalton, OH 44133.

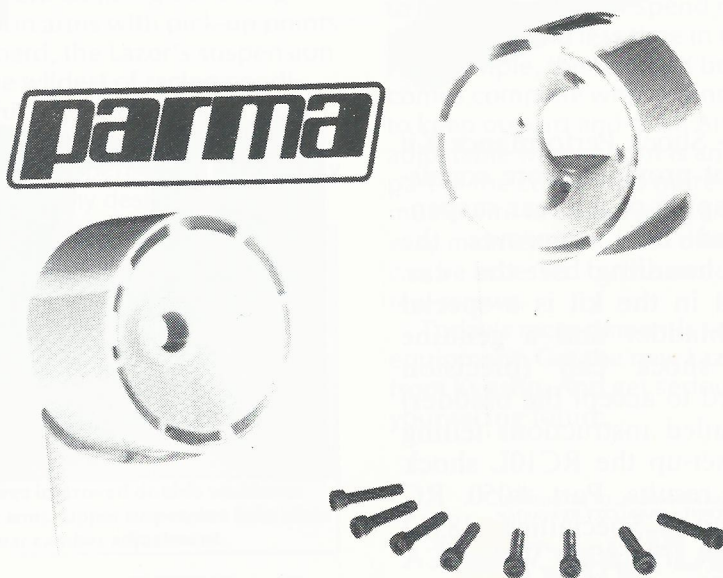

Part No. MM500 "Yokomo Front Hub Carrier" \$39.99. Beautiful machined, purple anodized, aluminum front hub carrier. This replaces the weak plastic parts and eliminates suspension problems. Comes with 2 ball bearings for smooth operation. Magic! Motorsports, 1901 East Linden Ave., No. 8, Linden, NJ 07036. (201) 862-1705.

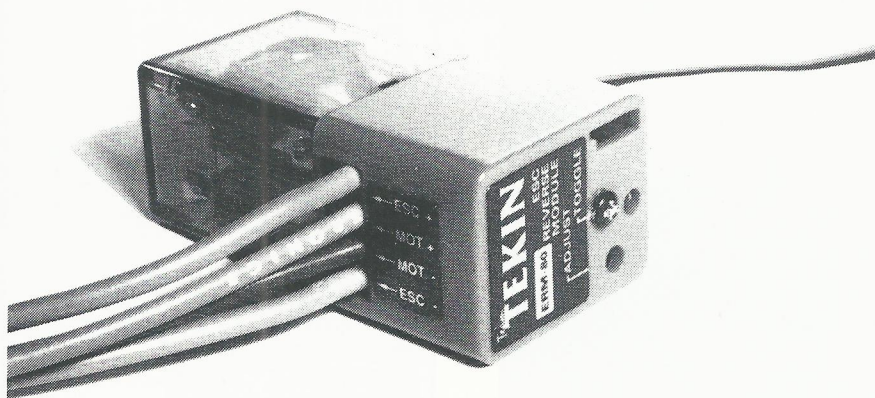
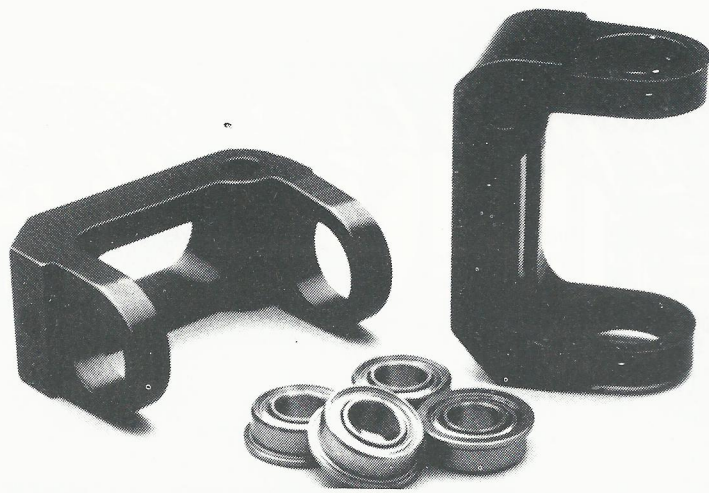

Now you can have reverse while still using a high quality electronic speed control. The new Tekin ERM-80 ESC Reverse Module allows you to add the capability of reverse to your existing ESC. Simply plug it in to your existing competition ESC, then whenever you want to use the reverse function you just push forward on your trigger . . . you now have reverse! When you are ready to go forward again, just press forward on your trigger and you will now go forward. It has been designed to be virtually indestructible, will handle up to seven cells and any motor as hot as 16 turns. Tekin Electronics, 970 Negocio, San Clemente, CA 92672, (714) 498-9518.

Chrome Rims - Gold and silver nylon rims that are sure to give you the winning touch in con-course judging. True BBS styling at an affordable price. Super lightweight yet incredible strength under the most demanding conditions. A fantastic blend of style and function. Real show stoppers. No. 9971 - No. 9980, \$5.95 F - \$6.95 R. Twinn-K Inc., P. O. Box 31228, Indianapolis, IN 46231.

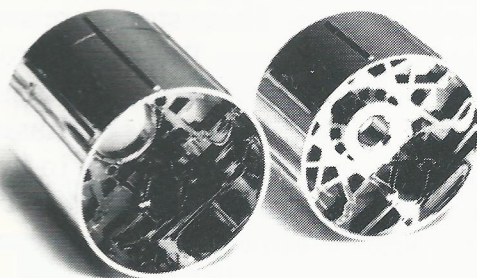

Advertiser's Directory

Competition Batteries



Tired of being "PUSHED" into team reject cells? You get our best 'cause we don't sponsor!

FREE GIFT (\$4.50 value) **WITH EVERY ORDER OVER \$50!!**

SANYO® SCR's STAGE III PROCESSED

STYLE	BEST FOR	STAGE III#	\$/CELL
UNLIMITED	SUPER SPDWAY	505 +	CALL FOR BEST PRICE
SUPER MOD	ON ROAD, OVAL	495-504	
SUPER STK	ON/OFF ROAD	480-494	
ULTRA STK	OFF ROAD	470-479	

SCE's ALSO AVAILABLE!

COMPETITION BATTERY SALES
32588 Dequindre, Warren, MI 48092

VISA MasterCard

313-588-2740
New Hours: 10-5 E.S.T.

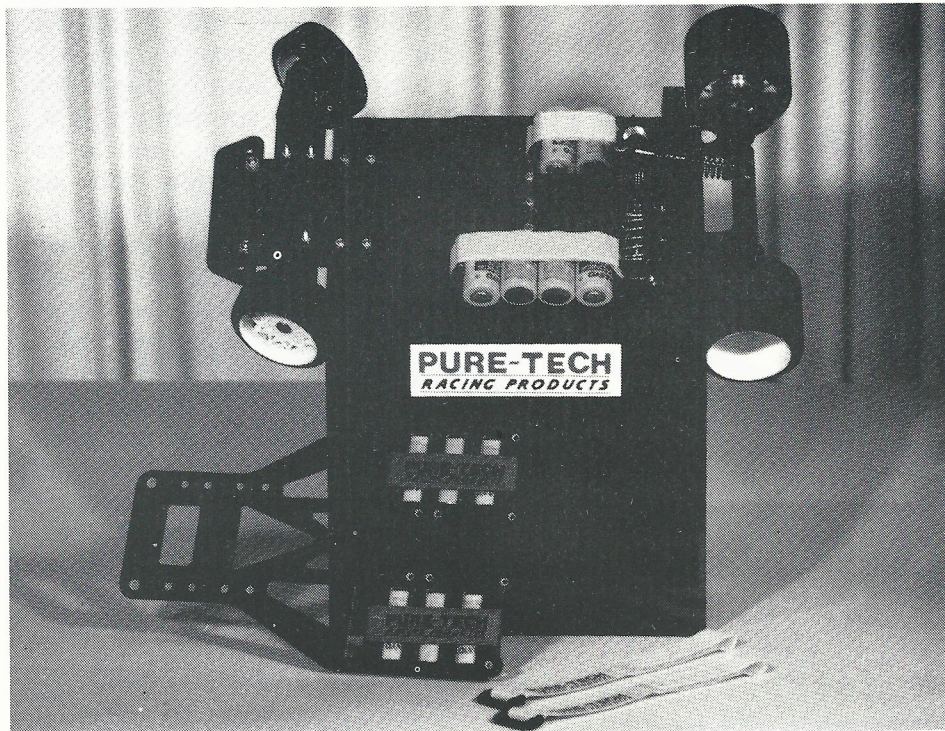

Pure Tech Racing Products announces their new Ultralight Velcro Battery Straps. These straps are super strong, nylon velcro straps for a slotted chassis. Proven by Pros at the Thunderdrome. These straps replace messy tape used on saddle packs. The straps are installed around battery and chassis, to hold batteries in place. They are re-usable and come in bright neon colors. Available for 6 cell, 7 cell, 4 + 2 split, 4 cell. Retail \$4.99. These Ultralight Velcro Battery Straps are also available for the Associated RC10, Losi JRx2, and Losi JRxT. Replaces battery brace and are mounted with stock screws. They weigh only 1/4 oz. on the car! (Half the weight of battery buckets.) Retail \$5.99. Available in bright neon colors! Pure-Tech Racing Products, P. O. Box 854, Tarazana, CA 91357, (800) 448-1898.

A & D RACING	68
A & L	66
ANDY'S PRODUCTS	10
ARCAR REG. 2 RACE	78
ARISTOTLE THROTTLE	51
ASSOCIATED	12, 93
ASTRO FLIGHT	41
B & B SOFTWARE	79
B & T RACING	25
BOCA BEARING	56
BOLINK	16
CKW	40
CLASS RECREATIONAL	80, 81
COMPETITION BATTERIES	10
COMPETITION PLUS	26
CONTROL ROOM	45
COORDINATED DATA	60
COX HOBBIES	Inside frt.
CUSTOM SCALE COMP.	11
DAHMS	63
DIALED RACING	83
ENDURANCE RACING	23
ERI	71
FAST RACING	57
FIVE STAR	86
FUTABA	Inside bk.
HOBBICO	96, 102
HOBBY HAVEN	29
HOBBY HAVEN RACE	28
HobbyShopper's Guide	42, 46
HORIZON HOBBY	61
HOT LAPS	65
HYPERDRIVE	51, 86
JG MFG.	48
KIMBROUGH	75
KING'S R/C	22
KYOSHO	96, 102
LEADING EDGE	17, 43
MEGATRAK	90
MODELER'S HAVEN	88
MRC	Back Cover
NORRCA OFF-ROAD NATS	54
NORRCA DIRT OVAL NATS	62
OASIS RACE	85
PARMA	21, 32, 84
PEAK PERFORMANCE	4
PROGRESSIVE TECH.	101
PRO-LINE USA	73
PRO SHOP	55
RC PERF. SPECIALTIES	8
RACER'S CHOICE	76
R/C SUPERDROME	72
REEDY MODIFIEDS	56
REG. 1 DIRT OVAL	34
REG. 3 RACE	70
REG. 5 RACE	74
RYDIN R/C	14
SRS	50
STAGE III	6
TEAM LOSI	49
TEAM PIT STOP	77
TEAM VOLCANO RACE	58
TEKIN	7, 30
TEXAS CONNECTION	47
T. M. RACING	13
TRACK MASTER	59
TRACK MATE	18
TRINITY PRODUCTS...3,9,15,24,52,53	
TRINITY RACES	64
TWINN-K	33
TWISTER MOTORS	64
VICTOR ENGINEERING	36
VERONA RACING PROD.	20, 44
WAGON HILL HOBBIES	83

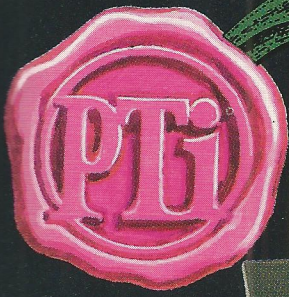

SUPER GOLDS...

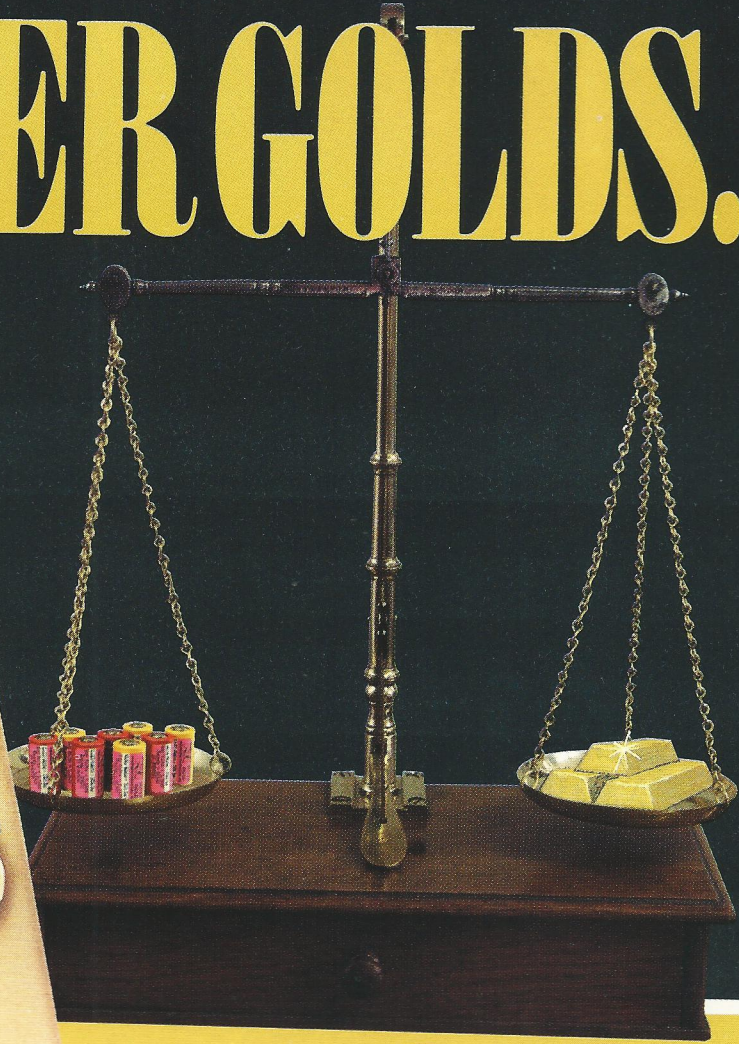

worth their weight in gold!

If you're serious about racing, you want the best equipment.

For your batteries, you spend a few hundred bucks on equipment, buy a few hundred cells and then spend a few hundred hours testing — to get some pretty-good stuff, if you're lucky. Or you can buy PTi Super Golds!

Precision tested on computerized LAVco matching equipment, thousands of cells go through rigorous charge/discharge cycles. Only the best make it to the Super Gold pack.

Every cell in your Super Gold pack must be within 3-seconds of the others... now that's Precision Matching!



Each cell labeled with capacity, voltage and total energy.

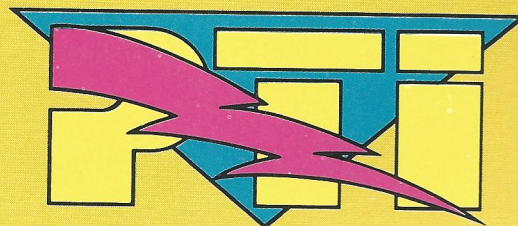

See PTi Super Gold today at your local hobby store or race track.
HOBBY DIVISION, P.O. BOX 4648,
WINSTON-SALEM, NC 27115-4648
TELEPHONE (919) 761-1375,
FAX (919) 748-0495

PROGRESSIVE TECHNOLOGIES, INC.
WE SEPARATE THE BEST FROM THE REST!

GENERATIONS AHEAD

KYOSHO®

ULTIMA II™



Begin your off-road racing career with a buggy that's up to every challenge.

The all-new **Kyosho Ultima II** brings the championship tradition of the 1/10 scale, 2WD Ultima into the 1990s. New developments include a chassis made of space-age Kelron™ and a fully adjustable suspension with adjustable front and rear upper links. Oil-filled, coil-over shocks mounted on duraluminum shock towers, a LeMans Stock 05 motor, and a heavy-duty rotary speed control are also included.

The Ultima II comes with a racing buggy body highlighted by an adjustable wing mount, fluorescent wheels, and low-profile racing tires. The proven Ultima gear box with differential remains intact, and the Ultima II accepts most of the existing Ultima hop-up parts on the market. As your experience grows, so will your Ultima II.

The next generation of Ultima has arrived.

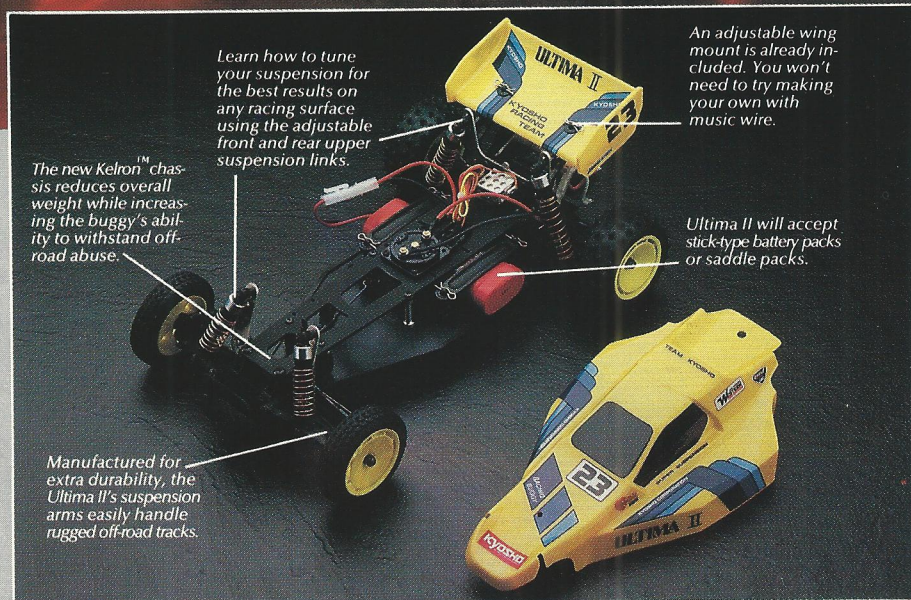

The new Kelron™ chassis reduces overall weight while increasing the buggy's ability to withstand off-road abuse.

Learn how to tune your suspension for the best results on any racing surface using the adjustable front and rear upper suspension links.

An adjustable wing mount is already included. You won't need to try making your own with music wire.

Ultima II will accept stick-type battery packs or saddle packs.

Manufactured for extra durability, the Ultima II's suspension arms easily handle rugged off-road tracks.

MAGNUM FORCE.



Tony Neisinger wins the 1989 Futaba Grand Prix with Magnum.

Every race day, more and more Magnums are showing up at the track. That's because Futaba makes a complete selection of Magnum pistol-grip systems to suit every kind of radio controlled car. Each Magnum system is loaded with competition features to give you an edge, whether it's your first race or the World Championships.

Get a grip on our hot, new 2PB/Sport. With a price as comfortable as its ergonomically designed case, the Sport is the perfect Magnum for the beginner. Servo reverse switching and convenient throttle and steering trims make set-up in any car or boat easy, and the Sport ESC option includes our MC112B MOS/FET speed control with reverse.

MOVE INTO THE WINNERS CIRCLE

Our grown up Magnum 2PBKA/Junior gives you some extra moves to put on the competition. Full range steering rate lets you perfectly balance your car's



2PB/Sport

(2PB and 2PBKA available with MC112B speed control)



2PBKA/Junior



2PD/AM

(2PD and 3PB available with S9301, S9601 or S132H servos)



3PB/PCM1024

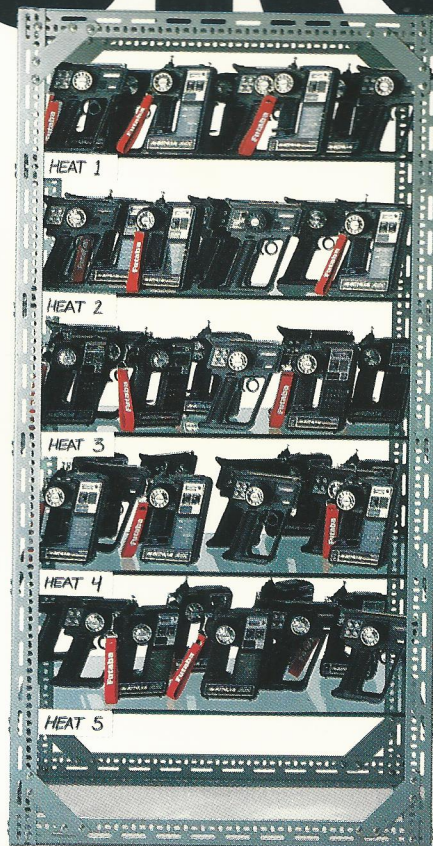

THE ALL NEW MAGNUM AM

The Magnum 2PD/AM is just what the serious racer ordered. Compact, yet fully equipped with pro-style, fine tune controls like steering rate, brake trim, throttle ATL, ATV and sub trim. The Magnum AM transmitter also lets you customize wheel throw and spring tension.

Like all Magnum 2 channel systems, the 2PD includes our new, narrow-band R102JE receiver. S9301 servos, the choice of most top 1:10 on and offroad drivers, are included, or you can choose S132H or S9601 versions.



Servo reversing, throw adjustment and sub-trimming can be individually preset on the 2PD control panel.

THE ULTIMATE MAGNUM

Racers who want it all turn to the awesome Magnum 3PB/PCM. The 3PB has everything you need for world class competition, in any class. Electronic trimming with sub trims and LED read-outs, programmable mixing, dual rates and exponential, plug-in RF module, DSC and more make the 3PB a uniquely refined and versatile performer.

And the incredible interference protection and resolution of Futaba's exclusive PCM 1024 put it in a class by itself.

MAGNUM
Futaba

Futaba Corporation of America
Four Studebaker, Irvine, CA 92718

Selecting an R/C off-road buggy can be difficult...MADCAP makes it easy.

High performance...simple to build.

Don't spin your wheels

If you're in the market for an off-road buggy, the selection is huge, the decision can be hard.

That's why MRC-Tamiya, the industry leader, developed the Madcap. A joy to build, the Madcap is designed to let you hop it up as your skills increase. So it's the perfect choice if you're just getting started.

You'll get high performance right out of the box, without spending hundreds of dollars to modify it. The Madcap comes standard with a powerful 540 motor and a rugged lightweight polycarbonate body. Standard equipment also includes a four-wheel, independent, double wishbone suspension system and four independent coil spring shocks with adjustable collars. It's engineered to bite in and hug the ground during high-speed turns.

Step it up, hop it up, speed it up...with MRC-Tamiya performance accessories.

Once you're ready for competition, hop-up your Madcap with one of three intimidating racing motors. Choose from the brutal Technigold RX-540VZ, the high performance Dynatech 01R, or the advanced Dynatech 02H. Each provides the torque and speed you need to compete.



Select racing tires with advanced tread design for better acceleration and handling. Add Tamiya's sealed ball bearings to cut down friction while blocking out dirt and dust. Or add Tamiya's C.V.A. or Hi-Cap oil-filled damper units. They'll provide the extra stability you'll need to stay on-track. Now that you know about the Madcap, your decision is easy.

Choose MRC-Tamiya's Madcap, and make your first R/C buggy a high performance off-road racer that can grow with you.

AVAILABLE AT YOUR HOBBY DEALER NOW!



MODEL RECTIFIER CORPORATION
200 Carter Drive, Edison, NJ 08817